



A.I.S. RADAR RECEIVER

USER INSTRUCTIONS

## Software Updates

1. **For convenience, channel selection has now been moved to the Threshold Screen.**
2. **Alternate A and B channel switching has been included (A, B, A, B...)**
3. **To reduce the waiting time for ship names they are now stored in memory.**
4. **The selection of the user's position on screen has been simplified. Selection is now made by pressing CONFIG, then CENTRE.**

## INTRODUCTION

The AIS radar consists of a dual frequency receiver, a powerful computer and a high contrast display.

Vessels carrying AIS transponders are plotted directly onto the AIS radar display. The tracks of each vessel show the true relative movement of all targets in the display.

The receiver is designed to operate from a 12 volt supply and requires a conventional marine VHF antenna (not supplied) and an input from a GPS receiver to give the user's position.

## INSTALLING THE DISPLAY

The AIS receiver is not waterproof and should only be cabin mounted. Select a convenient position for the display on a panel or bulkhead. The site must be flat and the cavity behind the panel must remain dry at all times. Cut a hole in the panel 103mm by 143mm wide.

Unscrew the wing nut from the rear of the receiver and take off the mounting clamp. Fit the 'O' ring in the groove on the rear and place the unit in the hole in the panel. Refit the mounting clamp and finger tighten the wing nut. Alternatively a cradle mounting kit is available where panel mounting is impractical.

Plug the power cable into the rear of the receiver and connect to 12 volts. (The red wire to positive and the wire with the black stripe to negative. The unit is protected against reverse polarity.)

Plug in the UTILITY cable supplied and, using the terminal block, connect as follows.

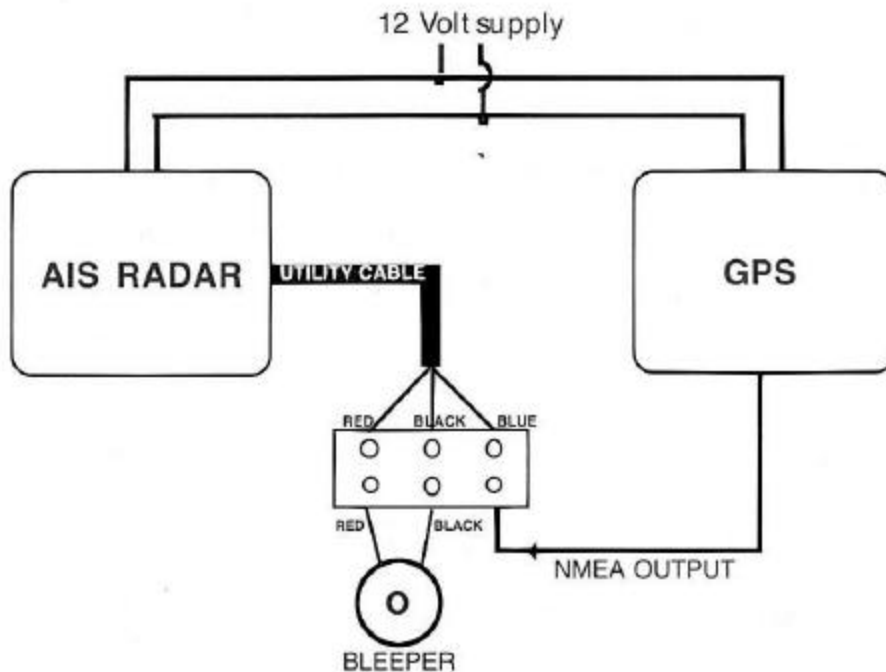

Connect the NMEA output (for NMEA+) of the GPS to the BLUE wire of the UTILITY cable. If the GPS has a NMEA – or NMEA REF connect this wire to the vessel supply negative. The AIS radar requires an NMEA 0183 signal with RMC sentence. The signal level must swing above and below 2 volts.

### **INSTALLING THE ANTENNA**

The receiver requires its own marine VHF antenna and cannot be shared with a transceiver antenna. It should be mounted as high as possible to maximize range but should be spaced not less than 1 metre from a transmitting antenna. The antenna cable should be at least 3 metres long and the antenna should be sited at least 2 metres from the AIS receiver.

## **SET UP PROCEDURE**

The setup procedure allows the user to:

- 1/ Set the receiver sensitivity threshold.
- 2/ Set the display contrast.
- 3/ Select the source of user position (from GPS or memory).
- 4/ Select the AIS channel (A or B)
- 5/ Select the screen update rate (8, 15, 30 or 60 seconds).

Once selected, these settings are held in a non volatile memory.

## **FROM THE INTRODUCTION SCREEN**

Select **SETUP**

- 1/ TO SET THRESHOLD: -select **THRESHOLD.**

A horizontal bar indicates the strength of the received signal. When viewed 'on air' the bar will start from a minimum position near the left of the screen and will rapidly shoot to the right of the screen as the short bursts of AIS signals are received. Using the **RAISE** and **LOWER** controls move the threshold setting bar until it is 1 or 2 stops above the minimum of the signal strength bar.

- 2/ TO SET THE CONTRAST: - select **CONTRAST.**

Use **LIGHTER** and **DARKER** to set the desired contrast.

- 3/ TO SET POSITION SOURCE: -select **CONFIG** then **POS'N**.  
The screen now shows the position source.  
To change:- select **GPS** to use the GPS position or press **STORED** to use the previously stored position. Press **BACK** to return to the previous page.  
To store a new position:- with GPS connected select **STORED** then press **SAVE**.
- 4/ TO SELECT AIS CHANNEL:- select **CONFIG**.  
Pressing **A/B** will alternate between the two channels. The display shows which channel is selected.
- 5/ TO SELECT THE SCREEN UPDATE RATE:- select **CONFIG**.  
Pressing **UPDATE** rosters through the update rate (8, 15, 30, and 60 seconds.) The display shows what update rate is selected.

## USING THE AIS RADAR

### **FROM THE INRODUCTION SCREEN:**

Select **LIST**. This screen shows AIS data received in real time. The data includes the ship's MMSI number, navigation status symbol and its latitude and longitude. It is this raw data that is used to plot on the radar display. It is possible to **FREEZE** this data for closer inspection and **UNFREEZE** it to return to normal.

The navigational status symbol shows the vessel's current status. A complete list of these symbols can be seen by pressing **ICONS** from the introduction screen.

Select **RADAR** to plot all the AIS targets on a simulated radar screen. Pressing **ZOOM** followed by **IN** or **OUT** will change the scale.

The radius of the outer ring can be set to 1, 2, 4, 8, 16 or 32 nautical miles. The selected scale is shown in the data box on the right of the screen. Pressing **OK** gets out of the zoom option.

As well as plotting the most recent positions of a vessel the display shows the last sixteen positions. This leaves a trail on the screen whose length and direction represent the speed and direction of the vessel relative to the user. The length of the track is also dependant on the screen update rate. For example, if the update rate is set to 15 seconds then a vessel will not have moved very far before the next position is plotted so the track will be short. If the update rate is 30 seconds the vessel will have moved twice as far each time the screen updates, so the track will be twice as long.

For reference a sample vessel is shown in the data box (just below the scale) together with its relative speed.

The AIS radar can track up to 24 vessels. If there are more than 24 vessels in range it will select the 24 nearest the user.

To select a vessel as a target press **DATA**. The closest vessel will be selected and the target symbol will appear on that vessel. Selecting **NEXT** or **PREVIOUS** will roster through all the vessels in range order. When the desired vessel is selected its AIS data will be printed in the data box on the next transmission. (The time taken to receive the information will depend on how frequently the vessel transmits an update.)

From the radar screen selecting **OPTIONS** then **TRACKS** puts the unit in time lapse mode. This is best appreciated when stationary. The display will now plot tracks of vessels entering the screen until they leave the screen. After a period of time (and this can be several hours) a map of shipping routes will emerge.

**NOTE – TRACKS WILL BUILD UP WHEN IN THE NORMAL RADAR MODE BUT WILL CLEAR IF THE RANGE IS CHANGED.**

### **ADVANCED SETUP**

It can be useful to place the user at a point other than the centre of the screen. To do this select **CONFIG** then press **BACK** and **UPDATE** simultaneously. Pressing **NEXT** will roster the centre through eight off-centre positions. Pressing **CENTRE** will return to the centre.

Note – The selected range is represented by the second range ring.

### **TO SELECT THE ALARM**

From the radar screen press **ALARM** to turn the alarm on or off. When the alarm is active an alarm symbol is shown at the top right of the screen. With alarm selected an audible alarm will sound when any AIS carrying vessel is within the inner range ring on the radar screen.

## **TROUBLESHOOTING**

Q – The screen is completely blank.

A – Check power supply. It should be 12 volts with the centre pin of the power plug positive.

Q – Signal strength bar remains at left of screen.

A – The unit is not receiving any AIS signals. Check VHF antenna.

Q – Signal strength bar is over to the right and hardly moving.

A – You are receiving some interference on that AIS channel. Switch off all other equipment to isolate source of interference. Simple changing the AIS channel may solve the problem.

Q – I cannot get good contrast on the display.

A – The unit needs at least 9 volts to operate the display properly. Check the battery voltage.

Q – The unit says that no GPS is present.

A – Check that GPS has been set up to send NMEA data RMC sentence.

Q – A target vessel shows a heading of 511 degrees.

A – This is a default number signifying that no heading data is available.

Q – A vessel appears to be jumping back and forth between two positions.

A – Probably two vessels with the same MMSI number. This should not happen as a ship's MMSI number is unique. Check the LIST, if two vessels share the same number then inform the relevant authority.

## Notes

## **Caution**

**Some vessels do not carry A.I.S.  
It is important at all times to keep a proper lookout.  
The A.I.S. radar is not a substitute for good seamanship.**

**SITEX**  Marine Electronics Inc.  
11001 Roosevelt Blvd., Suite 800  
St. Petersburg, FL 33716  
Tel: 727-576-5734 • Fax: 727-570-8646  
Web Site: [www.si-tex.com](http://www.si-tex.com)