





Pictorials





This manual uses the following symbols for easy understanding safety instructions. Always follow these instructions carefully.

 WARNING	Always follow this safety instruction to prevent death or injury.
 CAUTION	Follow this safety instruction to avoid possible injury or damage to your property. Symbol “△” is a CAUTION or WARNING label indicating the safety instruction.
 WARNING	This symbol is an Electrical Shock WARNING label.
	Symbol is an instruction that you must not violate. (This symbol instructs NOT to disassemble the system components)
	Symbol is an operation instruction that you must follow. (This symbol shows the main power OFF instruction.)



WARNING <For System Operators>

Always follow this instruction to prevent death or personal injury.

	Turn power off During abnormality.	If smoke or a smell of burning occurs, a fire or an electrical short circuit may result. Turn the power switch OFF and shut down the power supply immediately. Never try to repair the system yourself. Call for service.
	Do not open Cabinet.	High voltage exists in the instrument. Contact with voltage may cause possible injury or death.
	Do not touch back side of the equipment.	Harmful line voltage is present on back side of the equipment. Never try to touch back side while power is turned on.
	Avoid excessive shock to display unit.	The LCD display module contains a liquid. Do not apply any mechanical shock to the display. If the display is broken, liquid may leak and injure your skin and eyes.
	Do not use with poor ventilation.	If you cover this unit or use in an enclosed place, it may malfunction or become damaged as a result of overheating. Use only where there is sufficient ventilation.



Installation Cautions <For service Personnel>

Follow installation instructions to avoid personal injury and system malfunction.

Installation in rigid location.	Mount your SVS-650 on a rigid frame or base to prevent your unit from working loose.
Use correct Installation materials.	Use the installation materials provided in the standard accessory pack only. If you use hardware of insufficient strength, your system may loosen causing damaged.
Keep away from direct sunlight.	Keep your system out of direct sunlight as it may become damaged by overheating.
Keep away from water.	Take care not to get water on or in your unit as it may be damaged and/or cause an electrical shock.
Keep away from heat source.	Keep your system away from other heat source as it may malfunction, be damaged, or burn.
Use correct power source.	Operate your system within the specified power voltage. An incorrect power supply may cause



Maintenance Cautions<For Maintenance Personnel>

Use the following safety precaution internal inspection.

Discharge capacitors.	High voltage may be retained in the capacitors if the high-tension circuit several minutes after you have turned the power switch off.
Check that power is OFF	To prevent an electrical injury due to erroneous power switching, make sure that the main power supply and the system power switch are both in the off position. Additionally, attach a safety label showing that service is in progress.
Avoid EMI.	Take care not to damage the ESDs (Electrostatic Sensitive Devices) by static electricity from carpet and cloths.
Avoid dust.	Wear a safety mask so as not to breath in dust during inspection or cleaning inside your system instruments.

Operation Notes <For operators>

Observe the following operation notes, otherwise the system failure or deterioration can result.

And periodical inspection and maintenance are required for keeping the system in an optimum condition.

Backup important data.	The waypoint and other registered data may become unreadable by unexpected failure. We recommend recording this data separately.
Use correct transducer only.	If you use incorrect transducer, the transmitter circuit may be damaged due to a matching error. Consult us for system information.
Check transducer Connection before power on	Do not turn the power switch ON if the transducer is disconnected or if it is not inserted into the water. If done, the transducer or transmitter circuit may be damaged.
Always clean the transducer	Since transducer performance can drop due to accumulated bottom growth, keep the transducer clean. Never paint transducer surface.
Transducer must be installed by authorized personnel.	Consult us for transducer installation by authorized personnel.

 WARNING	This product is designed to assist a navigation. When you are sailing, use the certified chart from the Government or IMO.
--	---

SVS-650 Fishfinder System

CAUTION

The **SVS-650** Color LCD Fishfinder Systems employs the latest in proven technology to provide accurate fish & bottom information. The Plotter functions of SVS-650 are totally dependent upon the capability of the navigation source to provide accurate position information. This device is only an aid to navigation. It should be used in conjunction with all other navigation accuracy. For safety, always resolve any uncertainty before continuing navigation.

There is no direct relationship between the color of water areas and their depth. The navigator shall always query the area for depth information and use the official paper chart.

CAUTION

The performance of LCD displays are degraded by continuous direct exposure to ultraviolet rays. Locate your SVS-650 Display away from direct sunlight. When not in use. Keep the display covered.

DISPLAY BREAKAGE WARNING

The LCD display module contains a liquid. If the display is broken and the liquid contacts your skin, wash it off immediately in running water for 15 minutes. If the liquid contacts your eyes, immediately flush your eyes with running water for 15 minutes. Contact a physician if any abnormal symptom is experienced.

Welcome

Thank you for purchasing the SVS-650 from Si-Tex.

The SVS-650 is a premium multifunction Fish Finder System. SVS-650 front panel keyboard and its wide screen viewing area make placement easy. Although SVS-650 offers many advanced features, operation is simplified through the use of popup menus similar to those found on personal computers. The **SI-TEX SVS-650** Color LCD Fishfinder System opens a new chapter of performance and integration in Fishfinder system display and management. Whether you are a Cruiser or Sport fisherman or both, SVS-650 gives you the information you need.

Features of the SVS-650

Comprised of a display unit and a dual frequency transducer.

The main features of the SVS-650 are

- ▶ A large 6.5" Direct Sunlight Viewable High Definition LCD Display, in a vertical format to provide maximum sonar resolution! 480 x 750 pixels.
- ▶ Fishfinder offer's Superior fish detection and bottom discrimination using the new SI-TEX All Digital Sounder System.
- ▶ Instantly adapts to changing seabed and water conditions providing fully automatic "hands free" operation.
- ▶ A Powerful best in class 600 watt dual frequency 50/200Khz transceiver.
- ▶ Digital technology eliminates unwanted noise and provides the clearest images possible at all times.
- ▶ Multiple Display Modes: Normal (Single or Dual Freq.), Bottom Zoom, Bottom Lock, Shift, Split Screens, GPS Position, Waypoint Steering, Navigation Highway.
- ▶ Auto & Manual Range & Gain Controls, Each Frequency can be independently controlled! Also, Auto & Manual Shift.

Features of the SVS-650

- ▶ 10 Page Screen Capture Memory allows you to take Snap Shots of the Fish Finder Screen and save them to memory.
- ▶ 10 Event point memory allows you to instantly save a Fishing location and compute your course steering info back to the spot.
- ▶ Waterproof to IPX6 International Standard

- ▶ Very easy to operate, with front panel knobs for Gain and STC, Simple Menu Format, and all controls labeled in plain English.

- ▶ New White Line / Black Line Bottom Discriminator .

- ▶ Fish Symbols

- ▶ Depth Alarm, Sea Temperature Alarm, Fish Alarm

- ▶ Standard equipment includes Snap on Sun Cover.

SVS-650 Introduction

Standard Equipment Configuration List

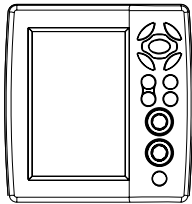

SVS-650 Display unit



Manual

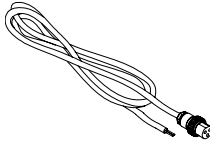

Power cable



Protector

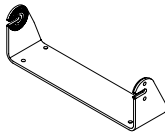

Mounting Bracket

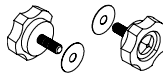

Knobs

SVS-650 Introduction

<Front>

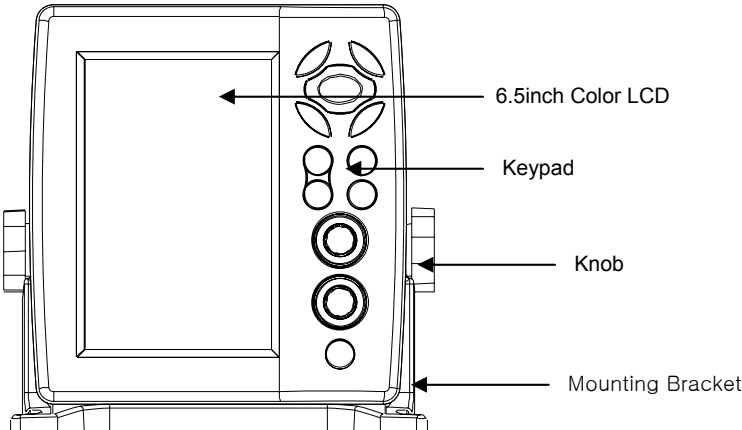

<Rear>

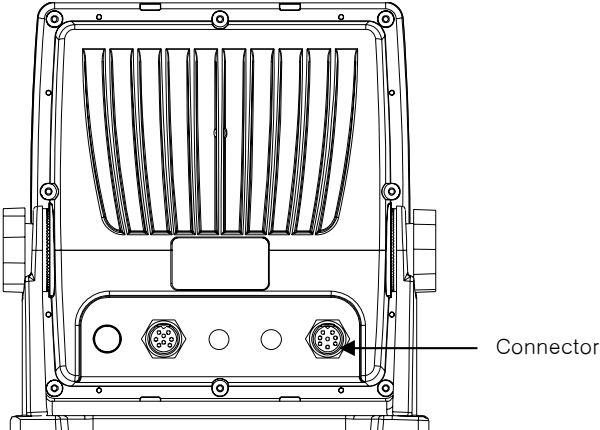

SVS-650 Introduction

Keypad

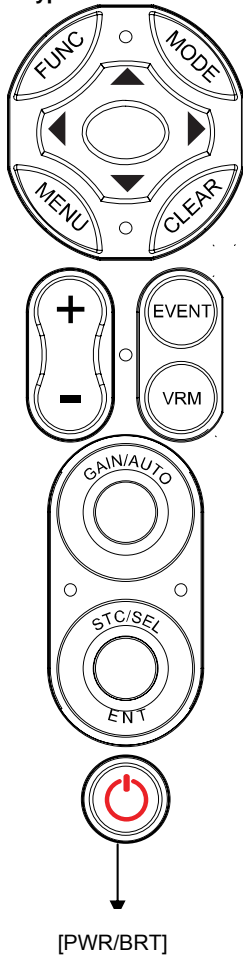

KEY	Description
[FUNC]	Setting up Using Frequently key function
[MODE]	Setting up Fishfinder mode
[MENU]	The main menu is displayed.
[CLEAR]	Return to the previous display, or canceled the set-up.
[RANGE]	Setting up the depth range, when depth range sets "manual range".
[EVENT]	Choose the Waypoint, setup Nav or capture functions for using one function.
[VRM]	Press the VRM key, and show the bar for the depth range.
[GAIN]	Button: Pressing the key, changes Auto Gain / Manual Gain. Rotary: Adjustment of gain level with turning.
[STC/SEL] & [ENT]	Rotary: No menu on the screen: turning rotary Dial for setting Menu on the screen : Available to Select menu Button: Enter when menu table on the screen
[Cursor Key]	With MENU: Choosing the menu & setting. Without MENU: Choosing the frequency(50/200KH z)

SVS-650 Introduction

How to use [Power/Brightness]

► Press [PWR/BRT]



1) **Turning off the power**

keep holding the [BRT/PWR] key until the end of the 3 second count down timer.

2) **Adjusting Screen Brightness**

Press [BRT/PWR] shortly and the brightness can be controlled.

Use the up/down Arrow keys of the cursor pad to control the brightness

3) **Selecting DAY/NIGHT Mode.**

Press [BRT/PWR] shortly and the DAY/NIGHT Modes can be selected.

Use the left/right Arrow keys of the cursor pad to select the Day or Night Modes

Choosing the Control Frequency on the Dual Frequency Screen

► Press [←][→] left/right Cursor Pad Arrow keys

You will see the red highlight box moving from right to left sides of the screen. The Active frequency is highlighted in the red.



Red Box

SVS-650 Introduction

Power I/O and Transducer connector wiring

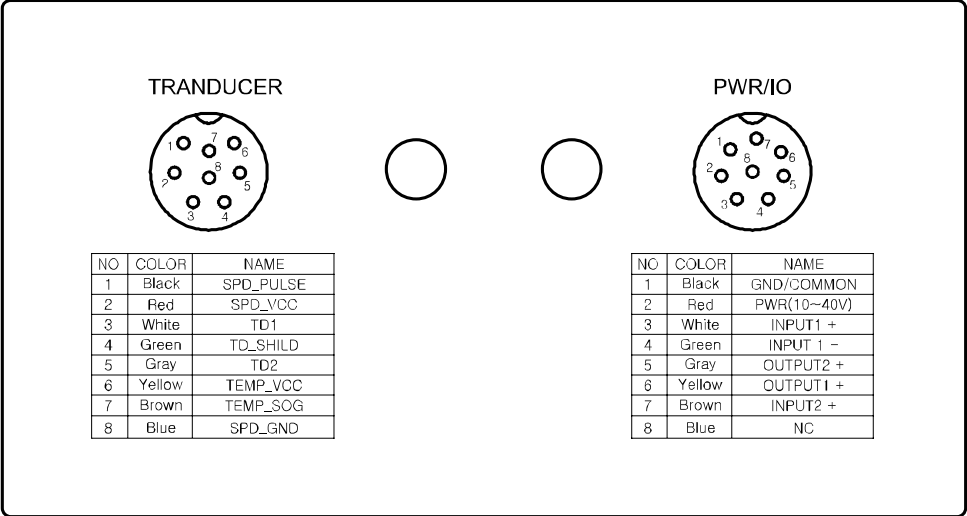

SVS-650 Introduction

Screen

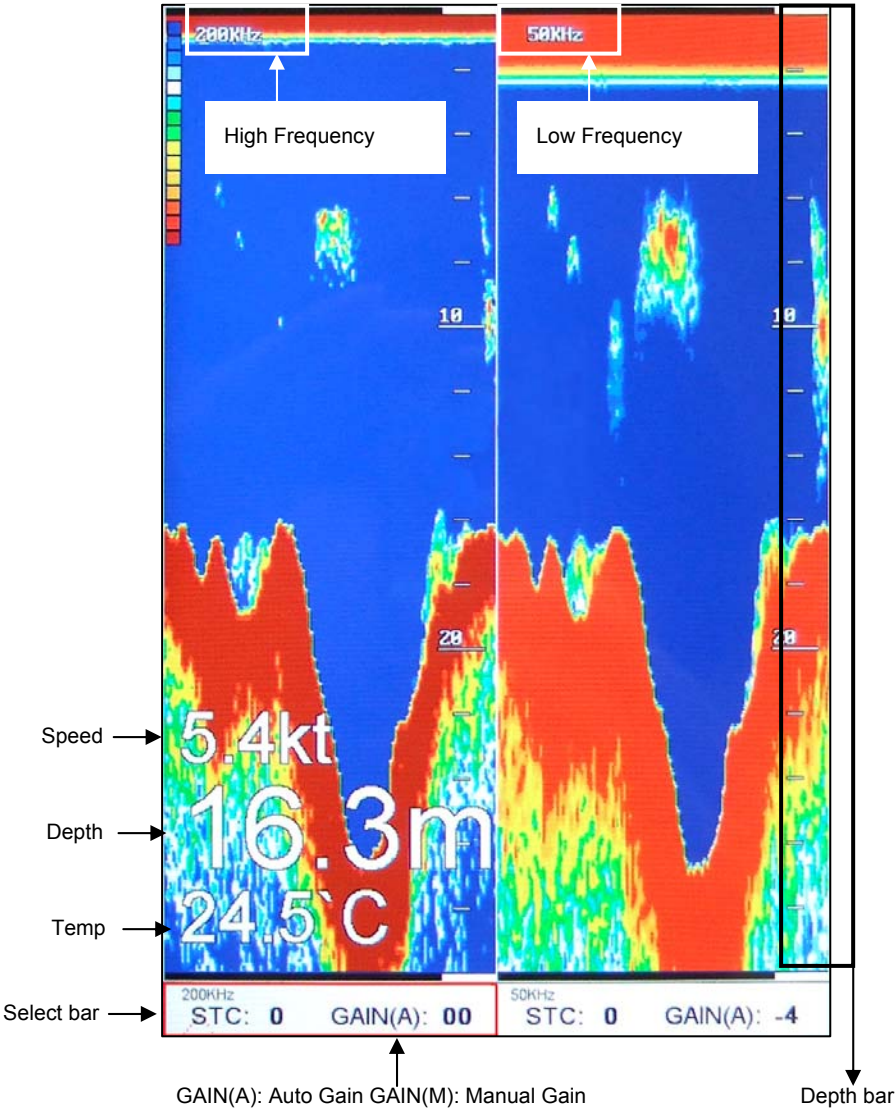

SVS-650 Introduction

Fishfinder - How it works-

The **SVS-650** echo sounder consists of a **transceiver** display unit and a dual frequency transducer. An electronic signal pulse is generated in the transmitter section of the display unit. When coupled to the transducer, this signal is converted into an ultrasonic signal and is transmitted toward the bottom. The signal travels through the water until it strikes an object or the bottom. It is reflected back, hits the transducer surface, and is reconverted into an electronic signal by the transducer. Then it is amplified in the receiver section, processed in the main logic section, and displayed, as an image on a LCD screen. (Picture 3)

When your boat travels from point A to point B as shown in Picture 1, the beam of the transducer installed on your boat shown a cross-sectional view in the water.

Picture 2 indicates a cutaway view under the water when your boat moves from A to point B.

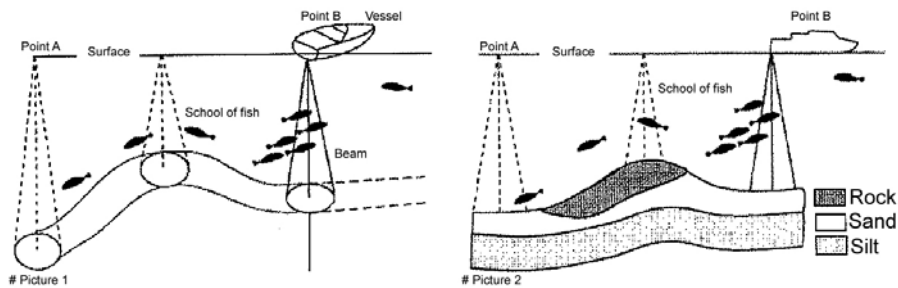

The screen shows the latest scan data at its right position. After the next scan, the previous data is moved to the left and the latest scan data is shown at the right position. When your boat moves from point A to point B, the screen shows the scan data as shown in Picture 3.

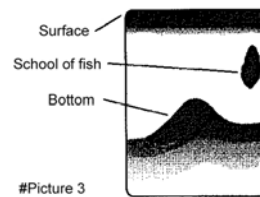

Installation of the SVS-650

A careful installation will assure maximum performance from your new SVS-650.

Display Unit Location

Select a location for your Display unit that provides easy viewing from all likely operator's positions.

The display unit is designed to be mounted on either a console or from an overhead surface. The

Display unit is also designed for flush mounting using six threaded holes on the rear panel. Locate the display in an area with protection from the elements and avoid direct sunlight on the viewing window.

Also, consider access to the rear panel of the unit for connecting power and cables to the various remote sensors. The mounting surface must be flat and solid to support the unit and prevent vibration.

There should be access to the inside of the surface to permit through bolt fastening for the mounting bracket.

Display Unit Installation

Temporarily install the mounting bracket on the SVS-650 display unit and place the unit at the selected location.



The Display unit is unstable when the mounting bracket is not secured. Hold the unit in place at all times.

Check the suitability of the location and make any adjustments. When all is satisfactory, use the holes in the mounting bracket as a guide and mark the holes locations on the mounting surface.

Installation

Drill a 1/4 in. diameter hole at each marked location. Mount the Display unit bracket using bolts through the mounting surface. Place large flat washers on the opposite side of the mounting surface from the bracket and then install lock washers and nuts. Tighten securely.

Install the display unit into the mounting bracket. Check alignment and operation of the pivots and security of the mounting. Make any adjustments necessary to prevent binding and assure even meshing of the pivot locking washers. It is advised to remove the display unit and store it in a safe place to prevent damage during the rest of the installation process.

Power Connection

Power is supplied to the Fishfinder Unit through a connector on the rear panel of the display unit.

Route the power cable from the Fishfinder Unit location to the ship's power distribution panel.

Connect the black wire to a battery negative (-) terminal of the power panel.

Connect the white wire to a fused battery positive (+) terminal of the power panel (12 to 24 Vdc nominal). If a fused terminal is not available, install an in-line fuse holder.

Transducer Connection

There are many transducers available which may be used to expand the capabilities of the **SVS-650** Fishfinder Unit. Connectors for these accessories are provided on the rear panel of the Fishfinder Unit.

See table on following page for list of optional transducers

SVS-650 Transducer Options			
Model #	Beam Angles	Type	Hole Size
250/50/200ST-CX	45° @ 50kHz 11° @ 200kHz	Plastic transom mount w/ depth, spd, temp.	N/A
1700/50/200T-CX	45° @ 50kHz 11° @ 200kHz	Bronze thru hull depth & temp.	7/8"
500/50/200ST-CX	45° @ 50kHz 11° @ 200kHz	Bronze thru hull depth, speed, & temperature	2"
P319/50/200T-ES	45° @ 50kHz 12° @ 200kHz	Plastic thru-hull flush mount with temp	2"
B-60-0 - CX (for 0° to 7° hull dead rise)	45° @ 50kHz 12° @ 200kHz	Bronze thru Hull, Tilted Element Flush Mount, Depth & Temperature Only	2.375"
B-60-12 - CX (for 8° to 15° hull dead rise)	45° @ 50kHz 12° @ 200kHz	Bronze thru Hull, Tilted Element Flush Mount, Depth & Temperature Only	2.375"
B-60-20 - CX (for 16° to 24° hull dead rise)	45° @ 50kHz 12° @ 200kHz	Bronze thru Hull, Tilted Element Flush Mount, Depth & Temperature Only	2.375"
810-15	15ft Transducer Extension Cable		
810-30	30ft Transducer Extension Cable		
Digital A Cable	Adapter Cable for use with All Dual Freq. CVS-106 Versions		

*All SVS Transducers come with a Conxall (Model #CX-128) 8 pin Conn. On the end of the transducer cable

Installation

Installing the Transducer Cable-

Thru-Hull and Transom-Mount Installation

cable, with the connector attached, is supplied with the transducer. During the installation, **do not cut the transducer cable or remove the connector**. Do not try shorten or splice the cable. The transducer cable includes several wires, along with shielding and insulation. If the cable is cut, it cannot be repaired. (Cutting the cable will also void the warranty.) During installation, if you need to drill any holes for the cable, they must be large enough to accept the connector (3/4" or 19mm). This will allow you to complete the installation without cutting the wire.

1st) For a transom-mount installation - Route the cable up and over the top edge of transom. Secure the cable using cable clamps. (These clamps are available from your local marine equipment supplier.) If you do not want to expose the cable on the deck, you may drill a new hole (3/4" or 19mm) through the transom for the cable. (Remember - this hole must be large enough to accept the cable with the connector attached. Do not cut the cable!) To seal the opening, use a feed-thru cap where the cable passes through the transom.

2nd) For either type of installation - Run the cable through the interior of the boat.

3rd) Be careful not to tear the cable jacket when passing it through bulkheads and other parts of your boat. Secure the cable in place using Nylon Wire Ties. Coil the extra cable and tie it out of the way.

4th) If transducer cable is not long enough, 15 & 30 foot extension cables are available from SI-TEX. When you attach the extension cable, be sure that the connections are tight and watertight. Use Dow Corning DC-4 or an equivalent sealing compound to protect the connector assemblies.

Installation

Installing the Power Cable-

1st) The 6-foot power cable supplied with the display unit should reach the source of DC power.

Connect the power leads directly to the main battery isolation switch or breaker, or route the power leads to the DC power distribution panel. At the power source, connect the red wire to the positive terminal (+), and the black wire to the negative terminal (-). The negative terminal may also be called "ground" or "earth." (The display unit is internally protected if you accidentally reverse the polarity of the power wires.)

2nd) Attach the red or positive wire to a 5 amp circuit breaker. If the unit is connected directly to the boat's battery, include a 2amp in-line fuse. (In-line fuses are available at most marine supply stores.)

3rd) To prevent any interference or electrical noise, separate the Fishfinder power wiring as much as possible from other devices. See the section on "EMC Installation Guidelines."

4th) If you need to extend the power wiring by more than 10 feet, use a larger wire size. This will allow the wires to deliver the correct voltage in spite of the longer wire distance. For runs of 20 to 35 feet, use #14 AWG wire. If you need to extend the power wiring, be sure all electrical connections are solid and durable. Insulate all connections using heat-shrink tubing or electrical tape. You may use crimp connectors or a terminal strip, but be sure to use good-quality marine-grade parts.

5th) Plug in the power cable at the rear of the display unit.

6th) When you press the Power button, the display unit should turn on. If the unit will not turn on and you suspect that you may have reversed the power connections, check the DC power lines all the way back to the battery. If the polarity is not correct, reconnect the leads properly and try again.

(The display unit is internally protected if you accidentally reverse the polarity of the power wires.)

Installation

Installing a Thru-Hull Transducer

Follow these instructions if you are installing the thru-hull transducer.

1st) Once you have decided where to install the transducer, drill the hole for the part. Begin by drilling a small pilot hole (1/8" or 3mm) from the inside of the hull. (This small hole can be filled easily if the mounting location is not suitable.) Before you drill the hole, be sure you will be able to reach the large nut on the top of the transducer, once it has been mounted. Also be sure there will be enough clearance for the cable. If there is a strake or other feature on the hull, drill from the outside of the hull instead.

2nd) Drill a larger hole from the outside of the hull using the appropriate size hole saw or paddle bit for the selected transducer.

3rd) Uncoil the transducer cable. Remove the large hex nut from the housing and slide it over the end of the cable.

4th) Thread the cable through the hole to the inside of the hull. Never pull or carry the transducer in place by pulling on the transducer cable.

5th) Apply a thin layer of sealant (1/8" or 3mm) to the transducer between the upper flat surface of the transducer and the faring block. Use a high quality marine sealant suitable for underwater use. (Caution do not use 3M 5200) Also apply a thin layer up the side walls. This should cover all of the threads where the part will touch the hull material, plus an additional 1/4" (6mm). This will seal the threads for the large hex nut.

6th) Push the transducer housing (with the sealant applied) into the hole from the outside of the hull. Twist the housing slightly to squeeze out any excess sealant and to get a good seal. Be sure that the transducer is aligned so that the correct part of the unit is toward the bow of the vessel. Hold or prop the transducer in place temporarily.

Installation

Installing a Thru-Hull Transducer

- 7th) Go to the inside of the hull and slide the hex nut over the end of the cable. Fit the hex nut over the end of the transducer and tighten it. (On a vessel with a wooden hull, do not tighten the nut completely right away. Allow some time for the wood to swell after the vessel is put in the water. Be sure that the correct end of the transducer is pointing forward see Picture 1-1
- 8th) Remove any excess sealant from the outside of the unit to assure smooth water flow over the face of the transducer.
- 9th) As soon as the boat is placed in the water, check for leaks. Check again within 3 to 5 hours. (You may not be able to see a small leak right away.) If there are any leaks, you must repeat the installation procedure.

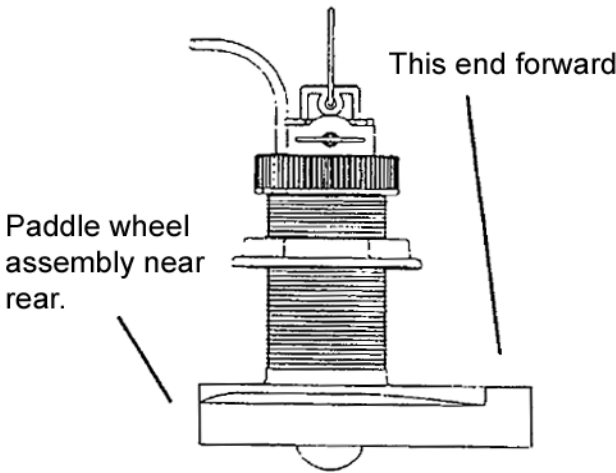

<Picture 1-1>

Installation

Positioning the Transom-Mount Transducer

Follow these instructions if you are installing the transom-mount transducer.

Begin by finding the best location for the mounting bracket. Here are the rules:

If your boat has one propeller (outboard or inboard-outboard), mount the transducer about 18" (455mm) to the side of the centerline of the boat. See Picture 1-2. Choose the side that is on the down stroke of the propeller. (This is usually the starboard side of the boat.) This will reduce any interference caused by air bubbles.

If your boat has twin propellers (outboard or inboard-outboard), place the transducer near the centerline of the boat.

If the propeller can be turned to steer the boat, allow at least 2" (50mm) beyond the swing radius of the propeller. This will prevent the propeller from damaging the transducer when it is turned.

Do not mount the transducer behind any hull fittings, intakes, or other parts which extend from the hull.

These may cause turbulence or air bubbles.

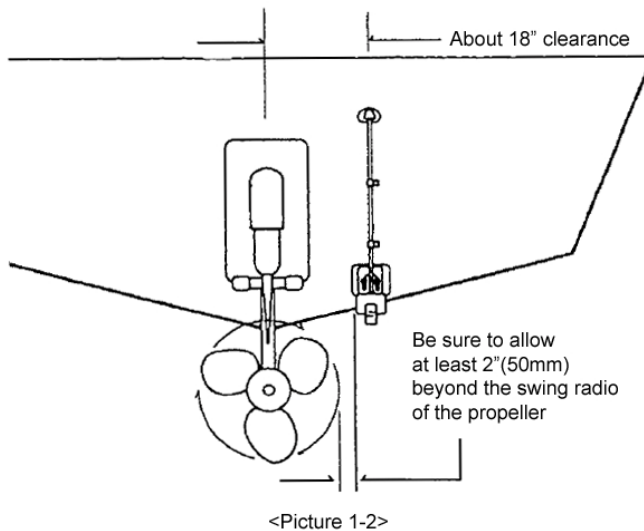

If the boat will be carried on a trailer, be sure the transducer will not hit any rollers, bunks or fittings on the trailer.

<Picture 1-2>

Installation

Mounting the Transom-Mount Transducer

Follow these instructions if you are installing the transom-mount transducer.

1st) On a boat with a fiberglass hull, the leading edge of the transducer should extend 1/8" (3.2mm) to 1/4" (6mm) below the bottom edge of the hull. See picture 1-3. On an aluminum hull, the transducer should extend a bit more - 1/4" (6mm) to 3/8" (9mm). If the boat will be operated at high speeds, the transducer may be mounted closer to the centerline of the hull.

2nd) The lower surface of the transducer should tilt down toward the rear at a slight angle (2° to 5°). The mounting bracket includes a wedge. Depending on the angle of the transom on your boat, you may need this wedge to get the correct angle for the bottom of the transducer.

3rd) Looking at the rear of the boat, be sure the bracket is vertical (perpendicular to the water line).

4th) Hold the bracket (and the wedge, if used) against the transom and trace the position of the screw slots.

5th) Remove the bracket. The screws in the outer slots should be placed about 1/4" (6mm) up from the bottom of each slot. The screw in the center slot should be placed 1/4" (6mm) down from the top. (This will allow you to adjust the bracket up or down a bit.)

Drill pilot holes 3/4" (19mm) deep. Use a 9/64" (3.5mm) drill bit. To prevent drilling too deeply, wrap masking tape around the drill bit about 7/8" (22mm) from the tip. Drill in only as far as the tape marker. If you are attaching the bracket to a fiberglass hull, you can minimize any surface cracking of the gel coat. Before drilling each pilot hole, drill a shallow hole (chamfer) at each location about 1/16" (1.5mm) deep. Use a 1/4" (6mm) drill bit.

6th) Attach the bracket to the hull using the pinhead screw with flat washers. Before you tighten the screws, apply a good-quality marine sealant to the pilot hole. This will protect the hull from water penetration. Do not tighten the screws completely yet.

Installation

- 7th) Tilt the transducer in the brackets until it is positioned as illustrated in Picture 1-3
- 8th) Once the bracket is in the correct position, you can tighten the screws.

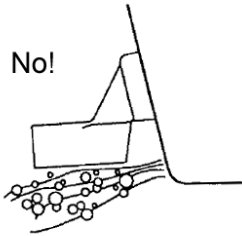
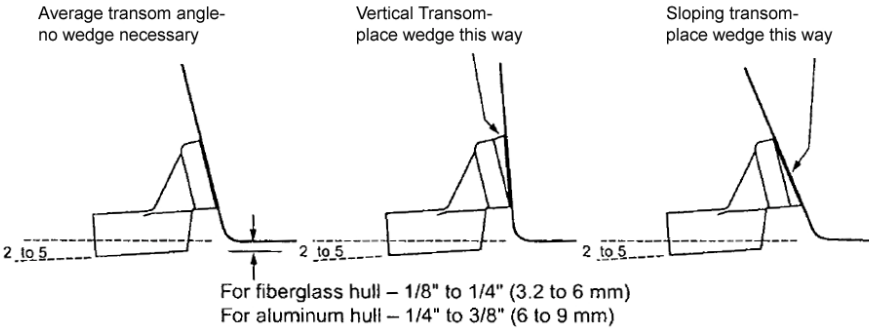

No!

The bow of the transducer is above the bottom of the transom, creating cavitation.

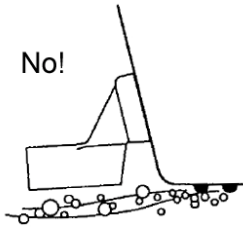

No!

Rivets on the hull are creating bubbles. Lower the transducer a bit.

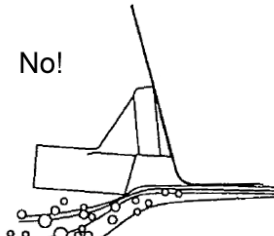

No!

The rear of the transducer is too high, creating cavitation.

<Picture 1-3>

Installation

NMEA-0183 Interfacing to a GPS

The power cable used on the SVS-650 provides for both DC power connection and for the Input output connections for NMEA-0183 devices such as a GPS Navigators or Chart plotters.

NMEA-0183	Description
\$GPDBT	Depth below transducer
\$GPDPT	Depth
\$GPMTW	Water temperature
\$GPTLL	Target latitude and longitude
\$GPVHW	Water speed and heading
\$GPGGA	Global positioning system fix data
\$GPVTG	Course over ground and ground speed
\$GPRMC	Recommended minimum specific GNSS data

NMEA-0183 Data Connections:

Data Input: Pin #3 White Wire = Data Input +

Pin #4 Green Wire = Data Ground -

Data Output: Pin #6 Yellow Wire = Data Output +

Operation of the SI-TEX SVS-650

Fishfinder Modes

The SVS-650 Fishfinder modes are selectable for single frequency or dual frequency, and split screen functions, for example bottom zoom or bottom lock.

FISH FINDER MODES

Normal	200khz
Bottom Zoom	200khz
Bottom Lock	200khz
Normal	50khz
Bottom Zoom	50khz
Bottom Lock	50khz
Normal	200/50khz
Bottom Zoom	200/50khz

► Pressing the [MODE] key allows you to select the following choices:

1. Normal (200KHz or 50KHz)

Normal mode (with Auto Range active) displays the sounder image with the surface at the top of the screen and the sea bottom in the lower part of the screen. The depth scale indicates the depth range appearing in the display. Bottom contours and fish echoes are displayed at the depths where they are detected. If the depth Range is set manually to a value less than actual water depth, sea bottom echoes are not displayed, but all other echoes within the Range setting are displayed.

Operation

2. Bottom Zoom (200KHz or 50KHz)

Bottom Zoom magnifies the sounder display from the sea bottom toward the surface for a short distance. The sea bottom contour is displayed and additional contour lines are added at intervals above the sea bottom to aid in determining distances of echoes near the bottom. Use the Sounder Menu to set the magnified Bottom Range from 2.5 to 20m (10 to 60ft.). Default setting is 10m (40ft.). If the depth Range is set manually, the setting must place the sea bottom echo in the lower portion of the screen for Bottom Zoom to be effective.

3. Bottom Lock (200KHz or 50KHz)

Bottom Lock divides the SVS-650 Fishfinder main screen image into two sections. The left hand section displays a Normal Mode image. The right hand section of the screen displays the Fishfinder image relative to the sea bottom. The sea bottom appears as a straight line with the Fishfinder image magnified for a short distance toward the surface. A scale appears on the right side of the screen for estimating distances of echoes near the bottom. Use the Fishfinder Menu to set the magnified Bottom range from 10 to 60ft (2.5 to 20m). Default setting is 40ft (10m) If the depth Range is set manually, the setting must place the sea bottom echo in the lower portion of the screen for Bottom Lock to be effective.

Bottom Lock modes are selectable for single frequency or dual frequencies.

4. Normal Dual Frequency (200KHz and 50KHz)

The high frequency (200KHz) displays on the left side and the low frequency (50KHz) displays on the right side.

5. Bottom Zoom Dual Frequency (200KHz and 50KHz)

The high frequency (200KHz) displays on the left and the low frequency (50KHz) Bottom Zoom displays on the right.

Operation

Display Modes

DISPLAY MODES

- Full Fish Finder
- Fish Finder + GPS
- Fish Finder + Highway
- Fish Finder + Steering

► [MENU]->[0.Others]->[4.Display Mode]

1. Full Fishfinder

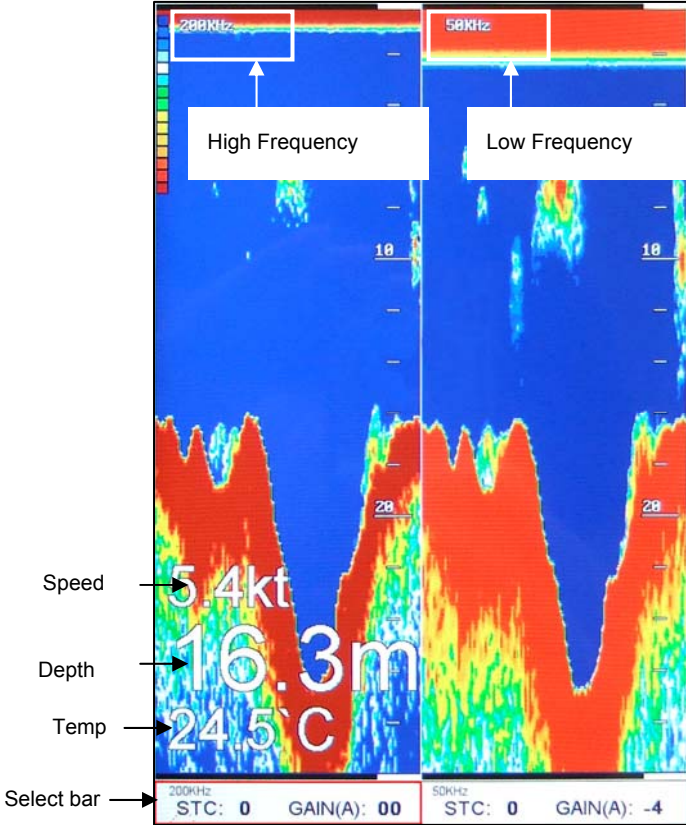

Operation

2. FF + GPS

The GPS display shows receiver status, position in latitude and longitude, course over ground, speed over ground, date and time.

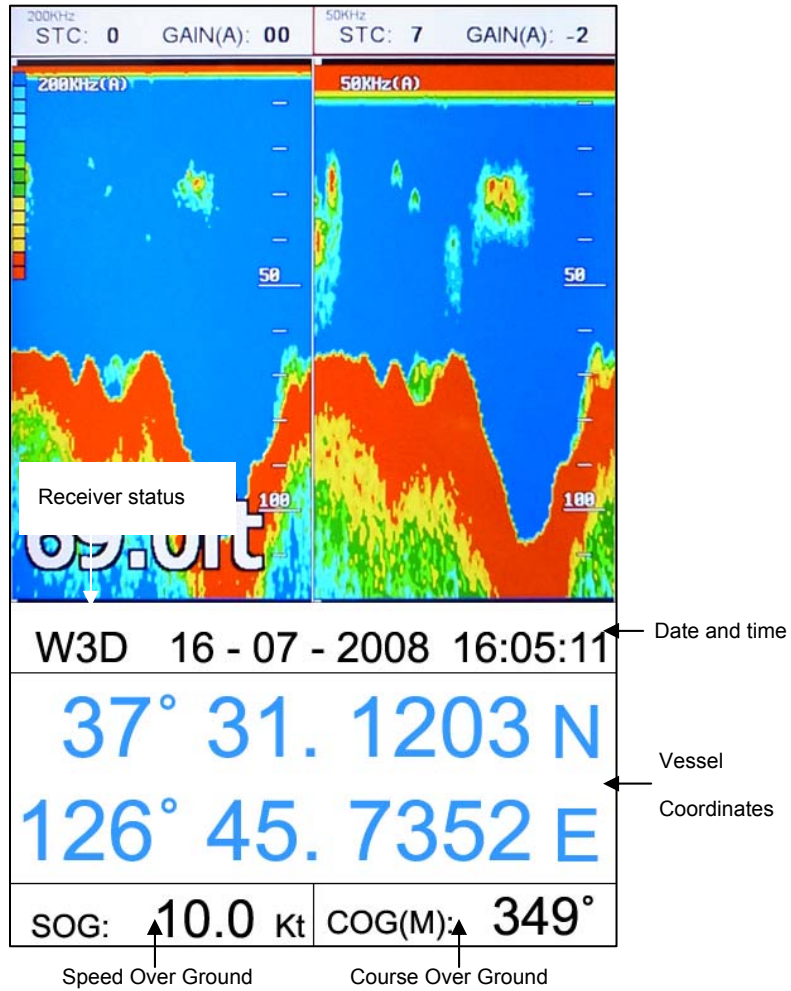

Operation

3. FF + Highway

The highway display provides a 3D view of own ship's progress toward destination (waypoint).

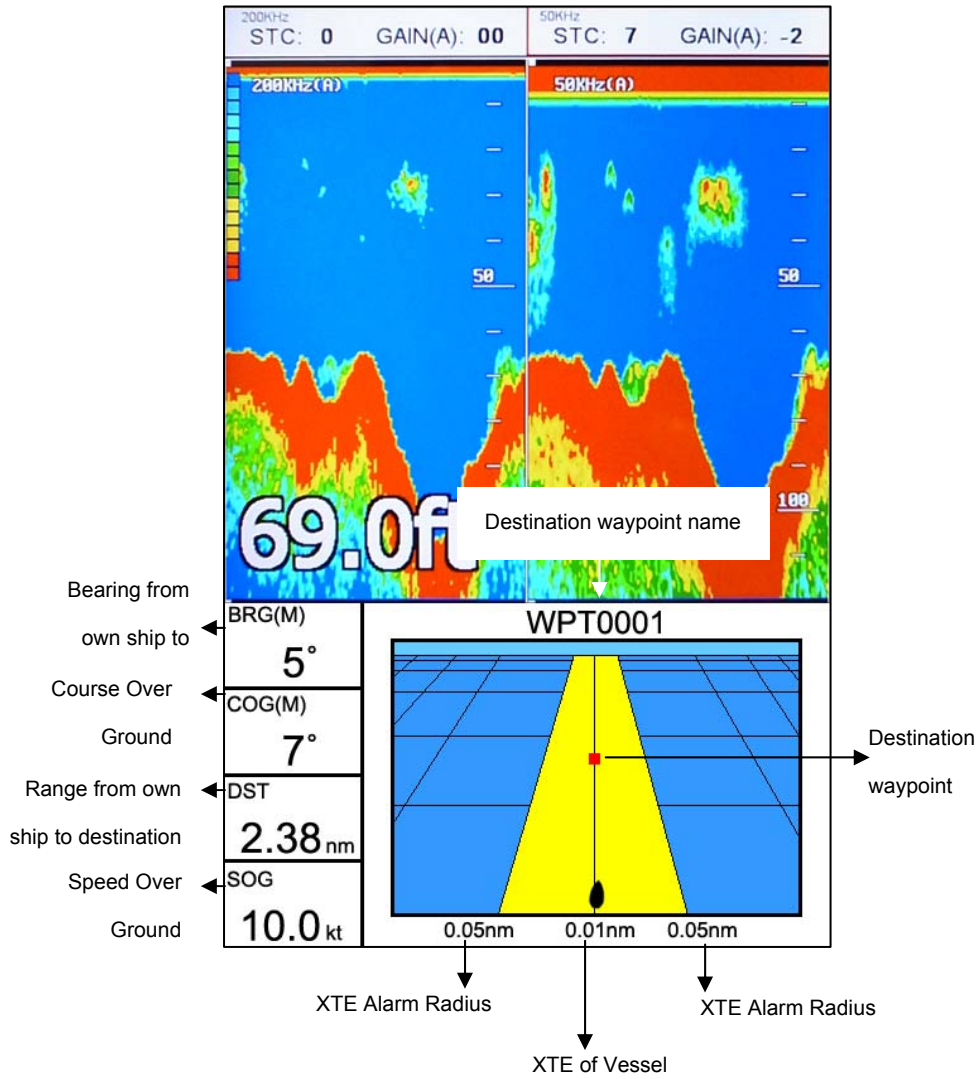

Operation

4. FF + Steering

The steering display provides steering information such as ship's speed, course, range, bearing, TTG.

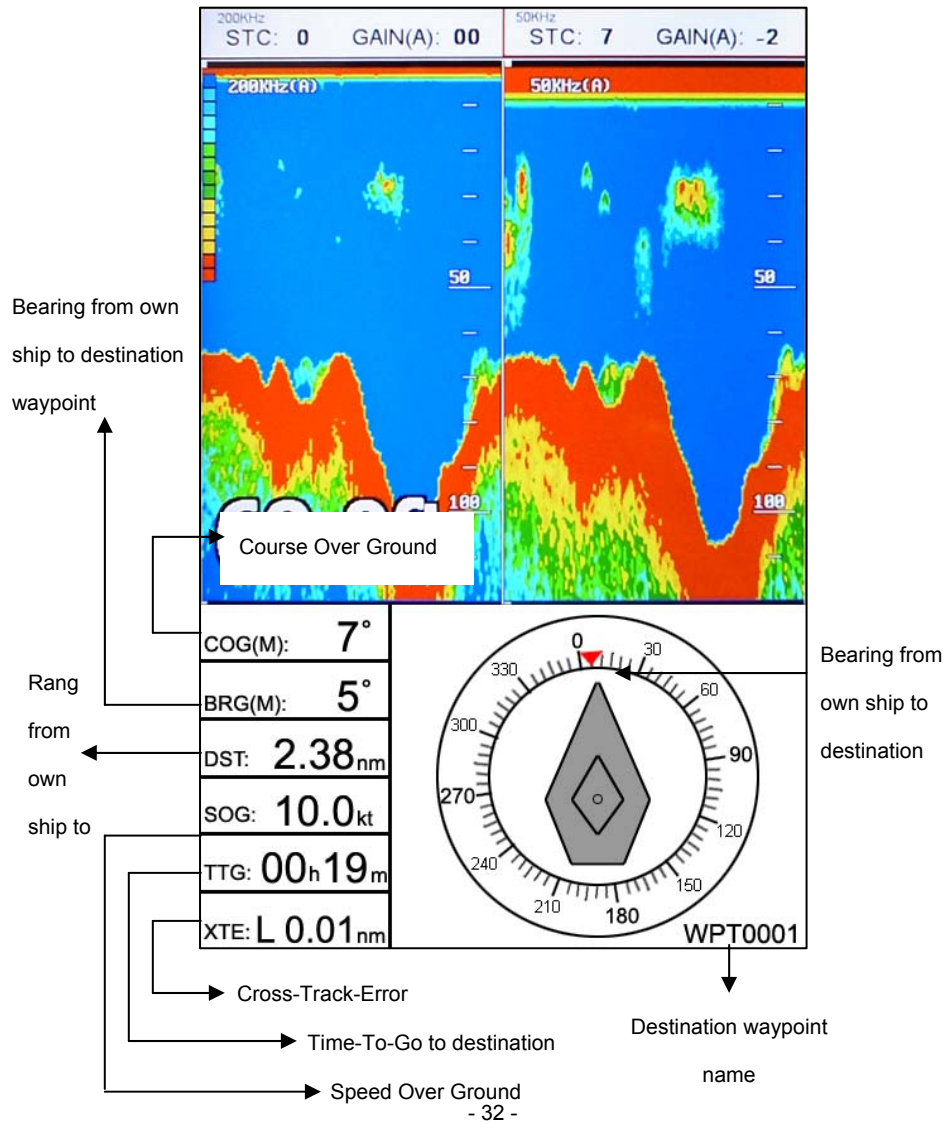

Operation

Gain

Setting up the gain.

1. Auto/Manual Gain

▶ Press [GAIN]

Press the key changes Auto Gain / Manual Gain.

(* Setting is available individually)

2. Set Gain

▶ Tune [GAIN]

Turn to the left, the gain level will be decreasing. Turn to the right, the gain level will be increasing.

(It is applied Auto Gain Adjustment, when the mode sets "Auto gain mode")

STC

Setting up the STC.

1. Set STC

▶ Tune [STC]

Turn to the left, the STC level will be decreasing. Turn to the right, the STC level will be increasing.

(*STC doesn't work on menu.)

Operation

Main menu

The menu and explanation of operation are displayed.

▶ [MENU]

1. Menu window

Selected column	MAINMENU			Setting value Red: Chosen	
↓	1.Manual/Auto Range	Manual	Auto		
	2.Shift				
	3.Display				
	4.Rejection				
	5.Color				
	6.Pulse	L	M	H	
	7.Output Power	OFF	L	M	H
	8.Alarm				
	9.General Setup				
	0.Others				

2. Setting the menu and changing the value

Choosing the column: Use the key, [▲][▼].

Setting value: Use the key, [◀][▶].

Operation

1. Range

▶ [MENU] -> 1. Range

SVS-650 selects the best condition for measuring the depth automatically in the environment of the sea.

(☞ The default setting is Auto.)

2. Shift

▶ [MENU] -> 2. Shift

A user selects this function to see more detailed bottom of the sea. When you turn up the shift, the range of Sounder shall go up from the shift range. For example, if you raise 5m of shift at 20m range, the surface shall start 5m and the bottom range shall be 25m.

(☞ The default setting is 0m.)

Operation

3. Display1/2 (* For change page, press [MENU])

▶ [MENU] -> 3. Display

3-1. A-Scope:

A-scope shows the research under the water by a scope to see the environment under the water.

(☞ The default setting is Off.)

3-2. Image Speed:

Select the speed of Sounder image from 4X until stop.

(☞ The default setting is 1X.)

3-3. White Line

It is necessary to research a detailed fish on the bottom or a seaweed under the sea. The color of the bottom changes into white or black to see the bottom easier than red.

(☞ The default setting is OFF.)

3-4. Bottom Zoom Range

Select the range of the bottom zoom or lock. It is necessary to modify the bottom.

(☞ The default setting is 10m.)

3.5.Depth

On/Off the depth range on the screen.

(☞ The default setting is ON.)

3.6.Depth Font

Select the depth range font size on the screen.

(☞ The default setting is Normal.)

3.7.TEMP

On/Off the temperature on the screen.

(☞ The default setting is Off.)

Operation

3. Display1/2 (* For change page, press [MENU])

3.8.TEMP Font

Select the temperature font size on the screen.

(☞ The default setting is small.)

3-9. Speed

On/Off the speed on the screen.

(☞ The default setting is Off.)

3-0.Speed Font

Select the temperature font size on the screen.

(☞ The default setting is normal.)

3. Display 2/2 (* For change page, press [MENU])

▶ [MENU] -> 3. Display->[MENU]

3-1. Fish Symbol

Fish symbol with sizes and levels show for targets.

(*Fish symbol is only for reference. This could be different from the real..)

(☞ The default setting is Off.)

Operation

4. Rejection

▶ [MENU] -> 4. Rejection

4-1. Interference Rejection (from engine)

When there are another boats around you on sailing, your sounder could be disturbed to work. The step of the function is from off to level 2. The bigger number, the more rejection.

(☞ The default setting is OFF.)

4-2. Noise Rejection

Your Fishfinder could be disturbed by the engine noise. This function can reject the noise from the engine or other machinery instruments.

(☞ The default setting is OFF.)

5.Color

▶ [MENU] ->5. Color

5-1. Bottom enhance

This function adjusts the colors. Make it upper level, the color becomes darker.

(☞ The default setting is 0.)

5-2. Color Rejection

There are 16 color levels for fishfinder. The color bar is on the left of the Fishfinder. If the level is higher, the color of the bar is deleted one by one.

5-3. Screen Color

Select the background color of the Fishfinder for your convenience.

Operation

6. Pulse

▶ [MENU] -> 6. Pulse

Select the pulse of the output from the transducer. Levels are from 0.5X until 1.5X, which depends upon the depth. 0.5X is proper to research precise a fish school but it is not suitable to measure a deep depth. 1.5X is opposite from 0.5X.

(☞ The default setting is 1X.)

7. Output Power

▶ [MENU] -> 7. Output Power

Select the output from the installed transducer. **Levels are from off, L,M,H,**. It should be careful about the depth. If you set high level in a shallow depth, the Fishfinder screen turns to red. You see nothing expect red on the screen.

(☞ The default setting is 3.)

Operation

8. FF Alarm

► [MENU] -> 8. FF Alarm

8-1. Depth Alarm:

It alarms when the set depth is out of the range.

(☞ The default setting is OFF.)

8-2. Depth Alarm Range:

Setup the range of Depth alarm

If it is deeper than the setting, it will alarm with the warning message.

If it is lower than the setting, it will alarm with the warning message.

(☞ The default setting is 10m.)

8-3. Temperature Alarm:

Position of the temperature is 4. It will alarm when it is out of the set range.

(☞ The default setting is OFF.)

8-4. Temperature Alarm Range:

Set up the range of Temperature alarm Range

If it is higher than the setting, it will alarm with the warning message.

If it is colder than the setting, it will alarm with the warning message.

(☞ The default setting is 0 degree.)

8-5. Fish-school Alarm:

It alarms when it detects school of fish.

It will detect school of fish depend on set depth, range and level of the fishfinder.

(☞ The default setting is OFF.)

8-6. Fish-school Depth:

If the alarm is on, It is available to setup the depth of the Fish-school

(☞ The default setting is 40ft.)

Operation

8-7. Fish-school Depth Range:

If the the alarm is on, It is available to setup the Range(hight) of the Fish-school.(The bar, next of display is shown)

(☞ The default setting is 50m.)

8-8. Alarm Interval:

If the the alarm is on, It is available to setup the alarm interavl.

(☞ The default setting is middle)

8-9. Color Level:

If the the alarm is on, It is available to setup the color level.

It is available to setup the color level

Operation

9. General Setup

▶ [MENU] -> 9. General Setup

9-1. System version

It contains ID and the program version, and it has important information for maintenance and upgrade.

9-2. Unit Setup

9-2-1. Distance/Speed Unit

Select desired unit of measure for distance and speed. Choose from: nautical mile/knots

(nm/kt), kilometer/kilometers per hour(km/kmh), mi/mph

(☞The default setting is nm/kt)

cf) 1nm = 1.852km, 1kt /h= 1.852km/h

9-2-2. Depth

Select the depth unit.

(☞The default setting is FEET.)

- M: Meter unit
- Ft: Feet unit
- Fm: FATHOM unit
- Ifm: Italy FATHOM unit
- Jfm: Japan FATHOM unit

9-2-3. Temperate

Select desired unit of measure for temperature of water. Choose from: Celsius(°C), or

Fahrenheit(°F). (☞The default setting is Fahrenheit.)

cf) 1°C = +32°F

Operation

9-3. Time Format: Sets your preferred time between 12 hour and 24 hour.

(☞The default setting is 12 hour.)

9-4. Date Format

Select the Date format

(☞The default setting is 1.)

- 1: YY-MM-DD
- 2: DD-MM-YY
- 3: MM-DD-YY

9-5. Output Sentence

The output of NMEA sentence can be set to On/Off.

NMEA	Description	Default
\$GPDBT	Depth below transducer	On
\$GPDPT	Depth	On
\$GPMTW	Water temperature	Off
\$GPTLL	Target latitude and longitude	On
\$GPVHW	Water speed and heading	Off
\$GPGGA	Global positioning system fix data	Off
\$GPVTG	Course over ground and ground speed	Off
\$GPRMC	Recommended minimum specific GNSS data	Off

9-6. Simulator

It is necessary for an indoor demonstration. The simulation of sounder is in the memory.

(☞The default setting is Off.)

Operation

9-7. Language:

650 supports three different kinds of languages, English, Chinese, Arabic, Thai etc.
Pressing the [ENTER], AUQA turns off and reboot the system for the new language.
(☞ When the language does not come out, inquiry to purchase place.)

9-8. Reset

All systems returns to the initial system.

- ▶ [ENTER] : reset without deleting user data.
- ▶ [FUNC]→[ENTER]: returning to the initial system from the releasing of factory.

(*All user data will be deleted)

9-9. Buzzer

Set the buzzer sound to On/Off.

(☞The default setting is On.)

9-0. Speed Source

Switch the Sensor/NMEA.

- InsideSensor: Use the built-in speed meter for sensor.
- NMEA: Use the external input value for NMEA.

(☞The default setting is InsideSensor.)

Operation

0. Others (CUSTOMIZING THE FUNCTION KEY & EVENT KEY)

▶ [MENU] -> 0.Others

0-1. Key Setup

It is available to set up [FUNC] key and [EVENT] key on the SVS-650.

0-1-1. [FUNC] key:

Set the function frequently used for your convenience.

(☞ The default setting is Display Mode.)

[FUNC] KEY SETUP
1.Display Mode
2.Image Speed
3.Color Rejection
4.Noise Rejection
5.Shift
6.Bottom Zoom Range
7.White Line
8.Pulse
9.Output Power
0.Reset

0-1-2. [EVENT] key:

Change the key of the Waypoint input, Setup Nav or capture.

(☞ The default setting is Capture.)

- Input Mark: Input the mark on the current position.
- Navigation: Start navigating toward the mark.
- Capture: Store the current screen.

Operation

0-2. Mark Setup

Setting up the Mark List, Edit, and Alarm.

0-2-1. Mark List:

Shown the mark list and it is available to set up or edit the mark on the list.

☞ Edit

Edit numbers, symbols, colors of Mark.

i) Editing Character

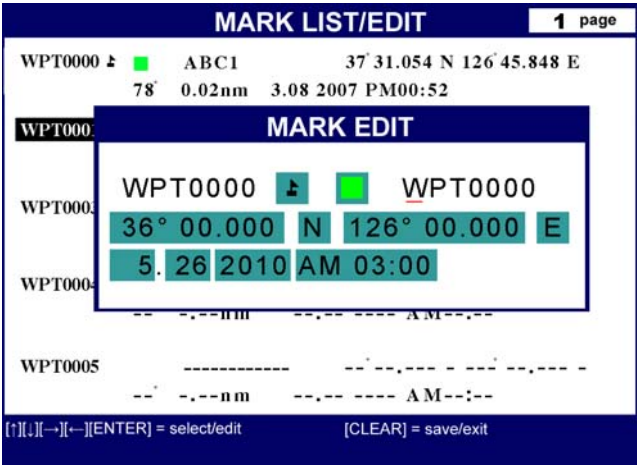

[←],[→]:
move the position

[↑],[↓]: change the character.

[ENTER]: choice

[CLEAR]: save and Exit

Operation

ii) Editing Number

MARK LIST/EDIT 1 page

WPT0000 ▲ ABC1 37° 31.054 N 126° 45.848 E
78' 0.02nm 3.08 2007 PM00:52

WPT0000 MARK EDIT

WPT0000 WPT0000 ▲ ABC1 WPT0000
36° 00.000 N 126° 00.000 E
5.26 2010 AM 03:00

WPT0005 -----

[↑],[↓],[←],[→],[ENTER] = select/edit [CLEAR] = save/exit

[←],[→]: move the position

[↑],[↓]: change the number

[ENTER]: choice

[CLEAR]: save and Exit

iii) Editing Symbol

MARK LIST/EDIT 1 page

WPT0000 ▲ ABC1 37° 31.054 N 126° 45.848 E
78' 0.02nm 3.08 2007 PM00:52

WPT0000 MARK EDIT

WPT0000 WPT0000 ▲ ABC1 WPT0000
36° 00.000 N 126° 00.000 E
5.26 2010 AM 03:00

WPT0005 -----

[↑],[↓],[←],[→],[ENTER] = select/edit [CLEAR] = save/exit

[↑],[↓]:move the bar

[ENTER]: choice

[CLEAR]: save and Exit

Operation

iv) Editing Color

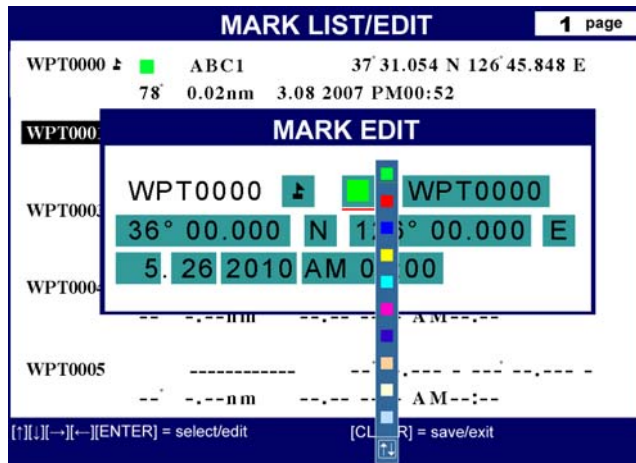

[↑],[↓]: move the bar

[ENTER]: choice

[CLEAR]: save and Exit

v). Goto Mark

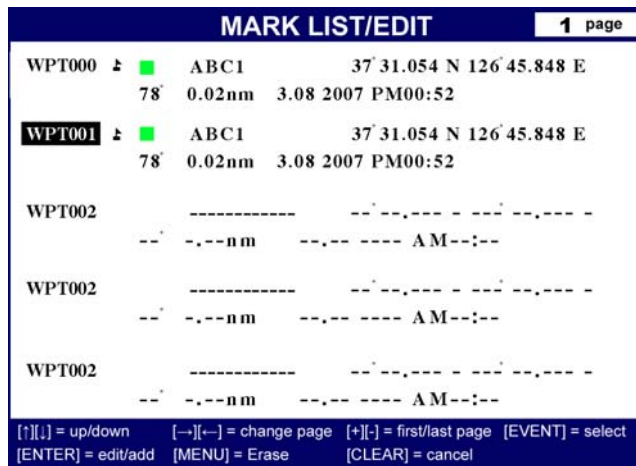

[↑],[↓]: move the bar

[EVENT]: goto

0-2-2. Alarm

0-2-2-1. Arrival Alarm:

When you approach into the waypoint range, it gives you a notice with alarm.

(☞ The default setting is OFF.)

Operation

0-2-2-2. Arrival Radius:

It is to adjust the range of arrival from your waypoint. If you have a route, it changes to the next waypoint automatically.

(☞ The default setting is 0.05nm.)

0-2-2-3. XTE Alarm:

If you are off course, it gives you a notice with alarm.

(☞ The default setting is OFF.)

0-2-2-4. XTE Radius:

It is to adjust the range of the off course.

(☞ The default setting is 0.05nm.)

0-2-3. Stop Navigation:

Stops the present navigation.

0-3. Capture List

Available to display and delete the capture file

▶ [MENU]->[5.Capture List]

CAPTURE LIST	
0000	CAP00000
0001	CAP00001
0002	CAP00002
0003	CAP00003
0004	CAP00004
0005	CAP00005
0006	CAP00006
0007	CAP00007
0008	CAP00008
0009	CAP00009

[ENTER]=View [FUNC]=Name edit
[MENU]=Erase [CLEAR]=Exit

Select bar → (points to the first row)
Order → (points to the first column)
File name ← (points to the first row)

Operation

VRM

► Press [VRM]

The VRM (movable marker) shown by the green line can be moved up and down.

It is convenient to measure the depth by aligning with the target such as school of fish.

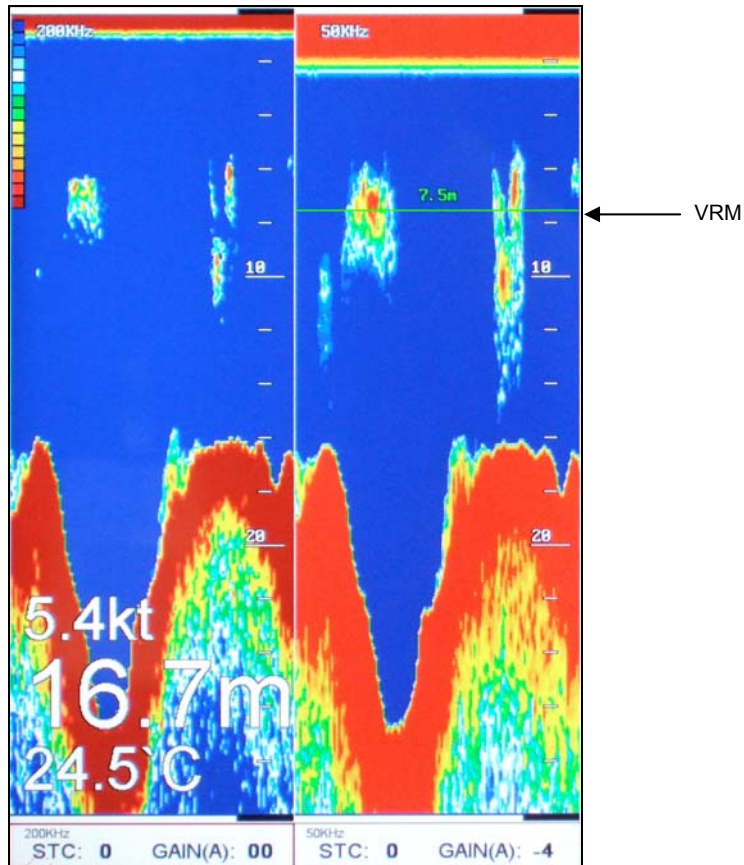

* Caution: When several seconds pass after finishing the VRM operation, **The screen reverts back to the normal display**

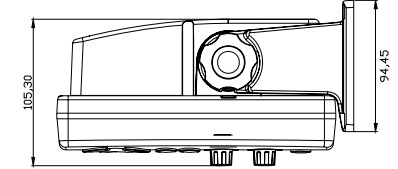

<Side>

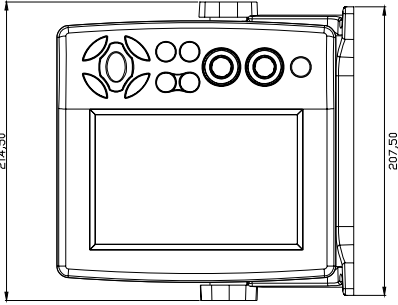

<Front>

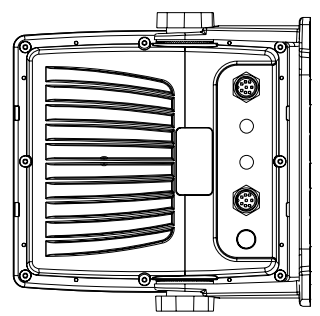

<Rear>

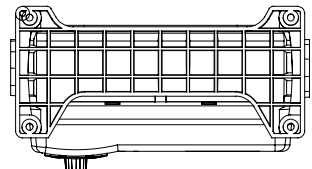

<Bottom>

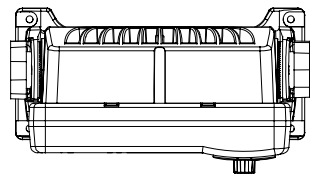

<Top>

MATERIAL		DESCRIPTION	
MODEL		Outline and dimensions	
SCALE	SVS-650	DWG. NO.	650-0003
1:1			
REFIN	CHK. BY	DES. BY	DRA. BY
G.T.RYU	Y.S. KIM	Y.S. KIM	Y.S. KIM
			DATE
			06.23.2010
SI-TEX MARINE ELECTRONICS			

CERTIFICATE OF LIMITED WARRANTY

Providing you present a valid proof of purchase, SI-TEX Marine Electronics Inc. warrants all parts of each new product against defects in material and workmanship under normal use and will repair or exchange any parts proven to be defective at no charge for a period of two years for parts and one year for labor from the date of purchase, except as provided below under Limited Warranty Exceptions. Defects will be corrected during normal working hours by an authorized SI-TEX Marine Electronics Inc. dealer, service center, or at the SI-TEX office in Riverhead, NY. There will be no charge for labor for a period of one year from the date of purchase, except as provided below under Limited Warranty Exceptions.

This Warranty and Proof of Purchase must be made available to the authorized SI-TEX Marine Electronics Inc. service location or dealer at the time of service.

LIMITED WARRANTY EXCEPTIONS

SI-TEX Marine Electronics Inc. will not be responsible for equipment which has been subjected to water or lightning damage, accident, abuse, or misuse, nor any equipment on which the serial number label has been removed, altered or mutilated.

SI-TEX Marine Electronics Inc. assumes no responsibility for damage incurred during installation.

This Limited Warranty is effective only with respect to the original purchaser.

Any cost associated with transducer replacement, other than the cost of the transducer itself, is specifically excluded from this Limited Warranty.

Travel costs incurred will not be accepted for SI-TEX Marine Electronics Inc. products.

THERE ARE NO WARRANTIES, WHICH EXTEND BEYOND THE DESCRIPTION OF THE FACE
HEREOF.

SPECIFIC EXCLUSIONS

Charges for overtime, stand-by, holiday, and per diem are specifically excluded from the Limited Warranty. Installation workmanship or materials except as provided directly by SI-TEX Marine Electronics Inc. are not covered by this Limited Warranty. SI-TEX Marine Electronics Inc. equipment or parts thereof, which have been repaired or altered except by an authorized SI-TEX Marine Electronics Inc. dealer or service center, are not warranted in any respect. Transducer, software update, battery, microphone, magnetron, and microwave components and water damage on water resistant VHF radio are items excluded from the two-year warranty and are covered by warranty for a period of one year for both parts and labor. SI-TEX Marine Electronics Inc. will not, at any time, assume any costs or labor charges for checkout or external line fuse replacement or problems not found to be at fault in equipment itself.

THERE ARE NO WARRANTIES OR GUARANTEES EXPRESSED OR IMPLIED WHICH EXTEND BEYOND THE DESCRIPTION ON THE FACE HEREOF, INCLUDING WARRANTIES OF FITNESS FOR A PARTICULAR PURPOSE AND MERCHANTABILITY. SI-TEX MARINE ELECTRONICS INC. HAS NO OTHER LIABILITY TO PURCHASE FOR DIRECT OR CONSEQUENTIAL DAMAGE OR ANY THEORY INCLUDING ABSOLUTE LIABILITY, TORT, OR CONTRACT. THIS LIMITED WARRANTY CANNOT BE ALTERED OR MODIFIED IN ANY WAY AND SHALL BE INTERPRETED IN ACCORDANCE WITH THE LAWS OF THE STATE OF NEW YORK. THIS WARRANTY IS LIMITED TO THE CONTINENTAL U.S.A., ALASKA, HAWAII, AND CANADA.

HOW TO OBTAIN SERVICE UNDER THIS WARRANTY

If you encounter problems during the installation or operation of this product, or cannot find the information you need, please contact SI-TEX Customer Service.

The contact numbers and e-mail address for SI-TEX Customer Service are:

SI-TEX Main Office.....+1-631-996-2690

SI-TEX Fax.....+1-631-996-2693

SI-TEX Service E-mail address: service@si-tex.com

SI-TEX Customer Support E-mail address: custsvc@si-tex.com

SI-TEX Main Office Address:

25 Enterprise Zone Drive, Ste 2

Riverhead, NY 11901

Technical Support is available from 9:00 AM to 5:00 PM Eastern Standard Time, Monday through Friday.