



UNIQUE AUTOPILOT DRIVES FOR CABLE STEERED BOATS

PROFESSIONAL SOLUTION - Replaces manual helm with a manual helm/autopilot drive combination.



TYPE S BEHIND DASH DRIVE



TYPE T TILT BEHIND DASH DRIVE

totally out of sight!!!

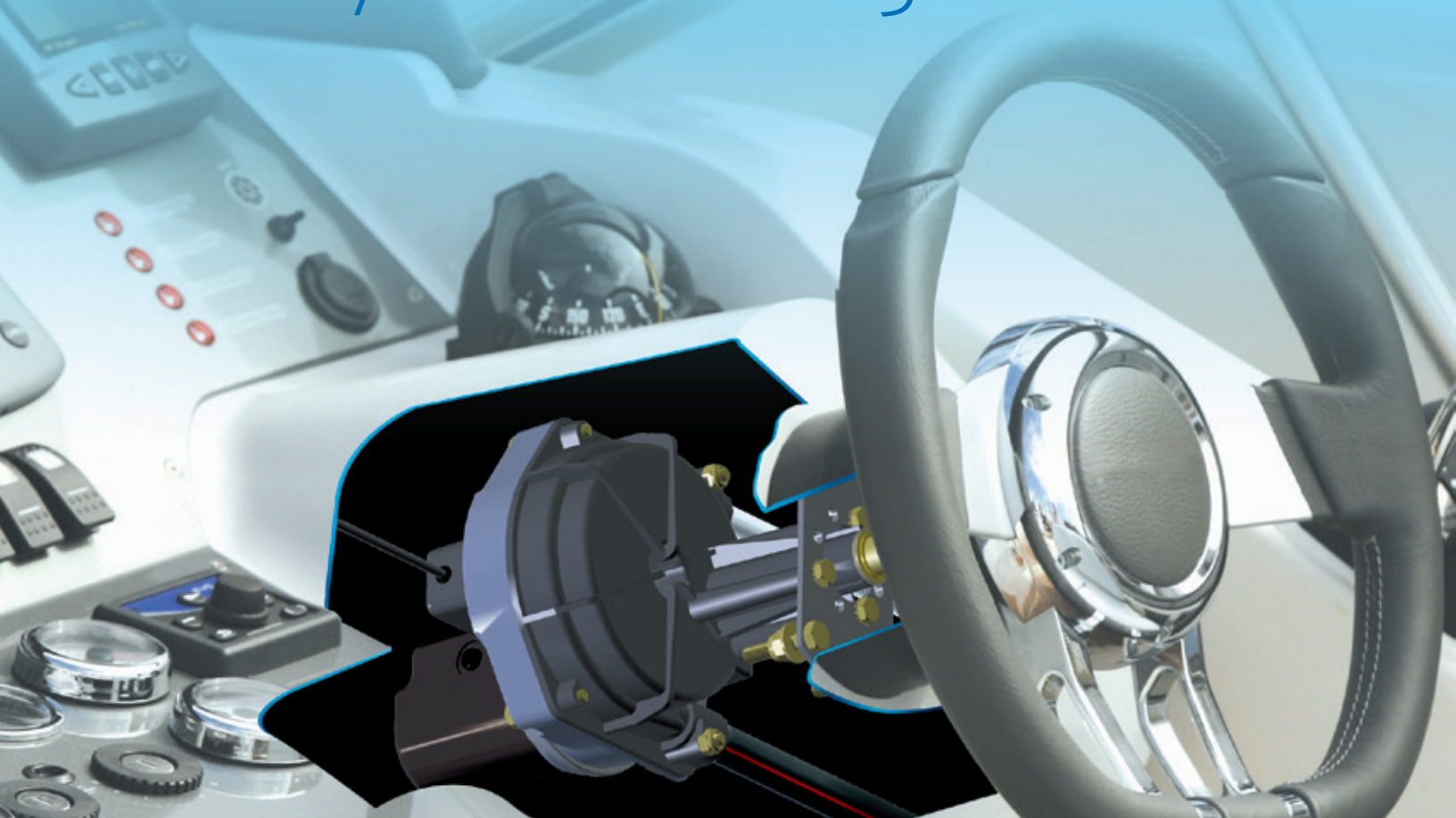

Type S/T mechanical dashboard drive specification



PROFESSIONAL SOLUTIONS FOR STERNDRIVE & OUTBOARD ENGINES

TYPE S BEHIND DASH DRIVE

The Straight shaft drive unit replaces the manual drive used on cable steered boats and is mounted directly behind the dash. The drive is directly compatible with the Morse 290 steering helm but comes with its own bezel kit and can be retrofitted in most installations using the cable and steering

wheel from the manual steering helm on the boat.

TYPE T TILT BEHIND DASH DRIVE

This drive unit replaces a manual Tilt drive and is mounted directly behind the dash, but still allows the angle of the steering wheel to be changed. It uses the front end from Teleflex SH91800 (not supplied).

SPACE REQUIRED - TYPE S & TYPE T

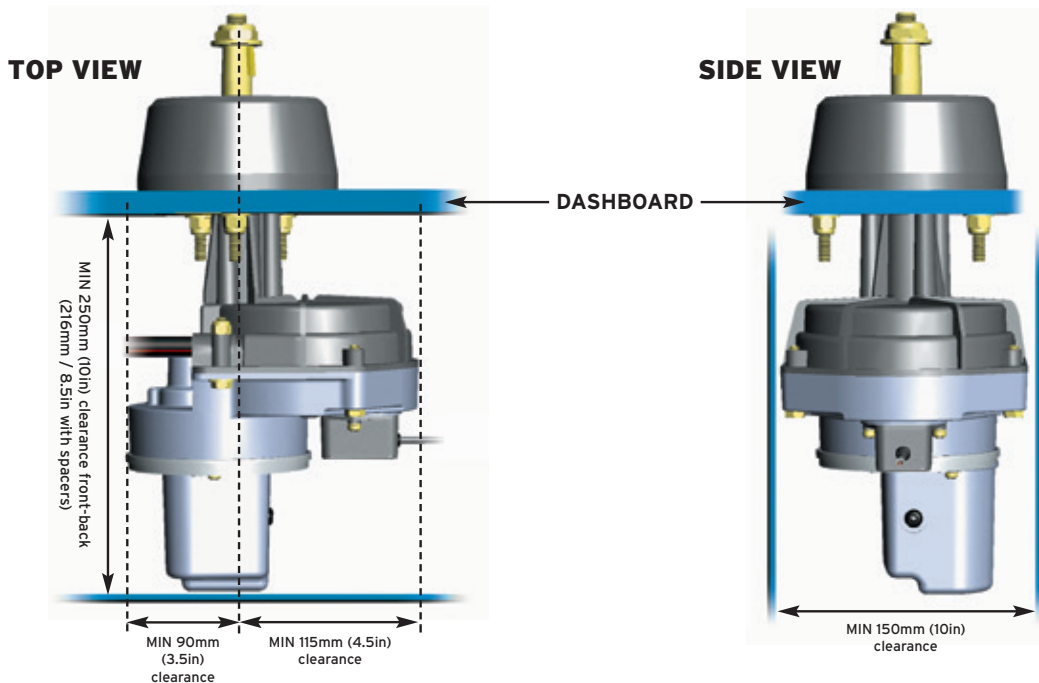

ACCESSORIES



OC15SUK10 90 degree Bezel Mounting Kit for Type S Straight Shaft Drive



OC15SUK09 20 degree Bezel Mounting Kit for Type S Straight Shaft Drive



OC15SUK07 Steering Cable Adapter Kit for TFX SSC72, Uflex M47, Morse 304415



OC15SUK08 Steering Cable Adapter Kit for TFX SSC62, Uflex M66



OC15SUK16 Spacer Kit x 19mm for 90° Bezel Kit
OC15SUK17 Spacer Kit x 16mm for 20° Bezel Kit
OC15SUK18 Spacer Kit x 13mm for TFX Performance

OPTIONAL RUDDER FEEDBACK UNIT

One of the most complex and time-consuming aspects of autopilot installation is fitting the rudder feedback unit, ensuring that the geometry matches the full range of rudder movement. The Octopus rudder feedback unit solves these problems as it mounts directly to the drive unit itself.



RUDDER FEEDBACK MODULES



OC15SUK27A For Sitex SP-70 Autopilots
OC15SUK27B
OC15SUK27D
OC15SUK27E For SI-TEX SP-110 & SP-120 Autopilots