



KODEN

INSTALLATION MANUAL

GPS RECEIVER MODULE

GPS-20A

This product is specifically designed to be installed on boats and other means of maritime transport. If your country forms part to the EU, please contact your dealer for advice before attempting to install elsewhere.

AMENDMENT HISTORY

GPS-20A INSTALLATION MANUAL
Doc No: 0092621632

No.	Document No & Rev No.	Date(D/M/Y)	Amendments
0	92621632-00	30/02/02	First issue
1	92621632-01	17/05/04	KODEN:address
2	92621632-02	26/05/04	Chapter5 5-5 Type C
3	92621632-03	07/04/05	GRA-20A→GPS-20A
4	0092621632-04	20/06/06	Cover
5	0092621632-05	31/10/07	Chapter 5
6	0092621632-06	12/08/08	Preface / Chapter 1 / Chapter 3
7			
8			
9			
10			

Amendment policy

When any change is applied in the document, only the document number of the relevant sheet(s) and cover sheet are modified and the rest of the sheets are not changed. The document number is shown in the footer area, right or left bottom of each sheet.

© 2003 2004 2005 2006 2007 Koden Electronics Co.,Ltd. All rights reserved.

No part of this publication may be reproduced, transmitted, translated in any form by any means without the written permission of Koden Electronics Co., Ltd. The technical descriptions contained in this publication are subject to change without notice. Koden assumes no responsibility for any errors, incidentals or consequential damages caused by misinterpretation of the descriptions contained in this publication.

Safety Precautions

- **Disconnect Main Power**

It is still possible to receive an electric shock caused by unintentionally switching on the power during repair work. To prevent this from happening, make sure to completely disconnect the unit from the ship's main supply before attempting any inspection.

- **Dust**

Dust can accumulate inside after long periods of use. Allergies can result from the inhalation of this dust, therefore during inspection and cleaning it is advisable to use a mask.

- **Static Electricity**

Static sensitive semiconductor devices are used in this unit. Before changing the printed boards be careful not to damage any of these devices due to electrostatic build up from carpet, clothes, seats, etc.

Symbols used in this manual

The following symbols are used in this manual. You are requested to be fully aware of the meaning of each symbol before carrying out inspection and maintenance of this equipment.

Alarm mark



Caution

To handle the equipment ignoring this sign may lead to a malfunction of the equipment.

Caution mark



Warning

To handle the equipment ignoring this sign may lead to injury to the human body or damage to the equipment.

Warning High Voltage mark



To handle the equipment ignoring this sign may lead to electrical shock to the human body.

Prohibition mark



This sign indicates that a specified action is prohibited. The prohibited action will be shown in the vicinity of the mark.

How to use this manual

Scope of this manual

This manual contains necessary information about installation of the GPS Receiver Module GPS-20A .

Structure of this manual

This manual is divided into sections according to the contents as described below. This arrangement will help you overview the whole of the contents as well as refer to detailed information for your specific requirement.

Summary of the contents

Chapter 1: Overview

- About GPS and SBAS
- Equipment outline
- Application standard
- Software specification
- Inter-connection diagram

Chapter 2: System composition

- Standard equipment list
- Optional items list

Chapter 3: Specifications

- Specifications
- Serial data
- Power supply specifications
- Compass safe distance
- Operating environment
- External dimensions and Weight

Chapter 4: Installation

- Installation precautions
- Unpacking and inspection of the goods
- Installation site

- Installation method

Chapter 5 : Technical references

- Serial input/output data
- Cable connections and connector pin-outs
- Input/Output circuits
- List of geodetic system

Chapter 1 Overview

Contents

	Page No.
1.1 GPS	1-1
1.1.1 GPS satellite alignment	1-1
1.1.2 GPS configuration.....	1-1
1.2 SBAS (WAAS, EGNOS, MSAS)	1-1
1.3 Equipment outline	1-1
1.4 Application standard	1-1
1.5 Software specification.....	1-1
1.6 Inter-connection diagram.....	1-2

Chapter 1 Overview

1.1 GPS

1.1.1 GPS satellite alignment

GPS (Global Positioning System) is a position measuring system that uses 4 satellites for each of 6 orbits (3 spare), with durations of 11 hours 58 minutes, orbiting approximately 20,000km above the earth.

1.1.2 GPS configuration

GPS is based on the principle of calculating the distance of 3 or more satellites from the user and deriving the user's position. The intersect point of the orbital trajectories becomes the current measured position (latitude, longitude, altitude).



Caution

GPS uses the (World Geodetic System) coordinate system. On previous global maps, each zone used a different coordinate system. However, by using the WGS system where all zones are unified to one coordinate system, the latitude and longitude are used in positioning. Therefore, when using a map that uses a different coordinate system, the map lat/lon may be different to the lat/lon displayed on the navigation unit.

1.2 SBAS (WAAS, EGNOS, MSAS)

SBAS is a robust system designed to greatly improve the accuracy of GPS positioning using geo-stationary satellites currently being produced in the US, Europe and Japan. There are 3 types of systems being produced, WAAS in the US, EGNOS in Europe and MSAS in Japan. WAAS and EGNOS are currently going through application testing and transmit position correction data at the same frequency as GPS satellites. Because position correction data is transmitted from geo-stationary satellites, it is possible to receive position correction data anywhere in the world. However, due to the fact that these geo-stationary satellites are still going through application testing, the quality of the position correction data may be degraded without notice.

1.3 Equipment outline

The GPS-20A is a high performance GPS receiver module containing an 18-channel parallel receiver sensor, which is ready for the SBAS service. By simply connecting a power supply to the GPS-20A, highly accurate position data can be quickly supplied to a Plotter or the ship's navigation devices. The GPS-20A is also compatible with differential correction service broadcast from conventional beacon stations.

1.4 Application standard

The GPS-20A conforms to the General Requirements of Maritime Navigation and Radiocommunication Equipment and Systems, IEC 60945 (Ed.3).

1.5 Software specification

PN-012

1.6 Inter-connection diagram

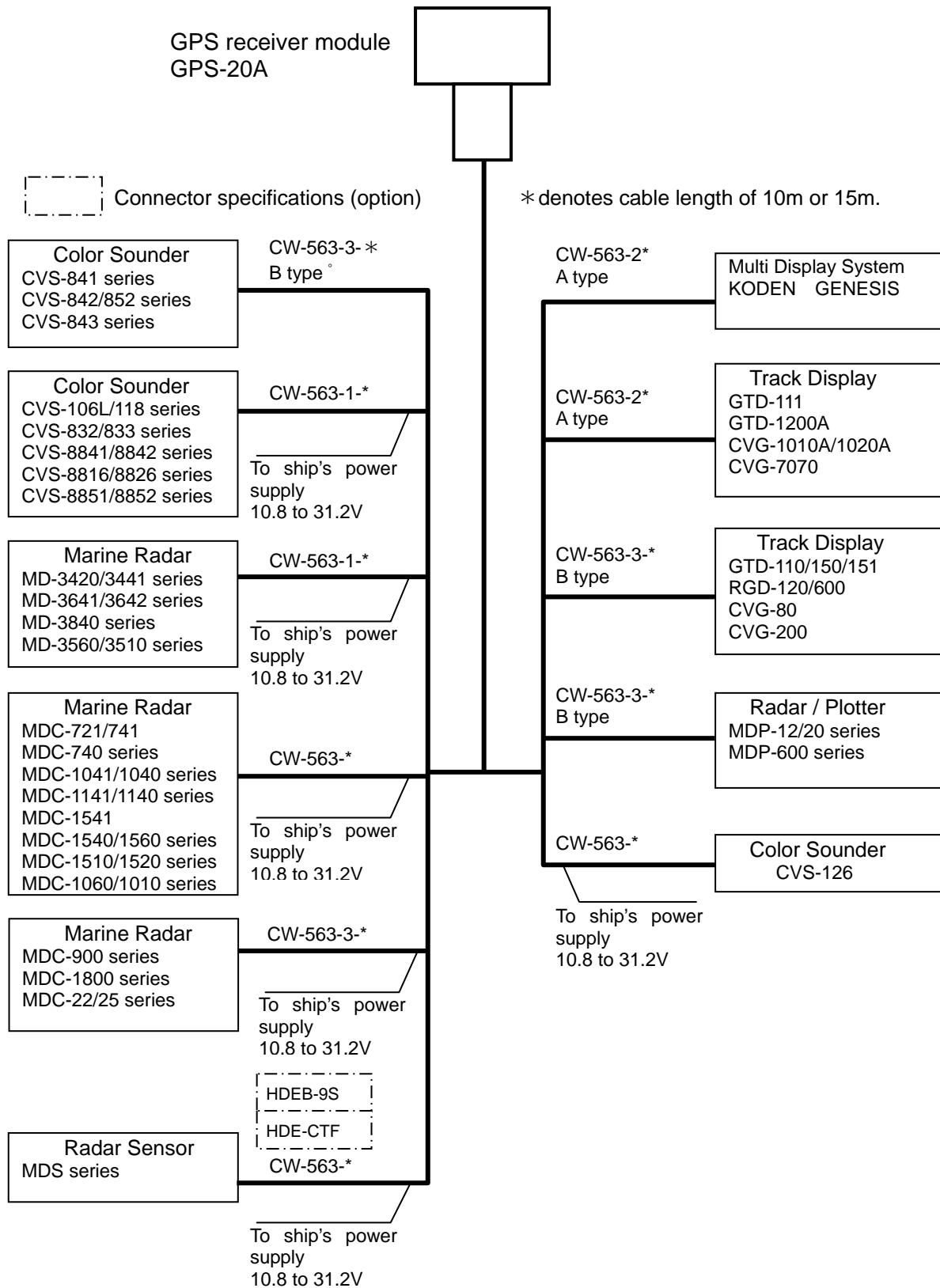

Fig. 1.1 Inter-connection diagram between GPS receiver module and GPS-20A unit

Chapter 2 Equipment Composition

	Page No.
2.1 Standard equipment	2-1
2.2 Optional items	2-1

Chapter 2 Equipment Composition

2.1 Standard equipment

No.	Name	Descriptions	Remarks	Weight	Q'ty
1	GPS Receiver Module	GPS-20A	Type name not specified Cable: CW-563-** M without connectors fitted	250 g (Cable not included)	1
			Type name not specified Cable: CW-563-1-** M with 6P connector (1006) fitted		
			Type A Cable: CW-563-2-** M with 6P connector (1006) fitted		
			Type B Cable: CW-563-3-** M with 6P connector (LTWBD-06BFFA-L180) fitted		
			Type C Cable: CW-563-4-XX M with 6P connector (LTWBD-06BFFA-L180) fitted		
2	Installation Manual	English			1

NOTE: The part with asterisk ** indicates the cable length specified. Standard length: 10 m, Optional length: 15 m

2.2 Optional items

No.	Name	Descriptions	Remarks
1	Connector	1005	5 pin
2	Connector	1006	6 pin
3	Connector	LTWBD-06BFFA-L180	6 pin, waterproof type
4	Connector	HDEB-9S	D-sub 9 pin
		HDE-CTF	Plug jacket

Chapter 3 Specifications

	Page No.
3.1 Specifications.....	3-1
3.2 Serial data.....	3-1
3.3 Power supply specifications	3-1
3.4 Compass safe distance	3-1
3.5 Operating environment	3-2
3.6 External dimensions and Weight	3-2

Chapter 3 Specifications

3.1 Specifications

Receive frequency		1575.42MHz ± 1MHz
Receive channels		18 parallel channels
Sensitivity		-130dBm
Positioning accuracy (PDOP≤=3)	Position	GPS: 10m (2drms, SA=OFF, PDOP≤=3) DGPS: 8m (2drms, SA=OFF, PDOP≤=3)
	Speed	1m/sec (rms, SA=OFF, PDOP≤=3)
Tracking	Speed	350km/h max
	Accel.	Below 1 G
Position update time		1 sec. (3 sec: option)
Positioning time	Cold start	50secs (standard value)
	Warm start	45secs (standard value)
	Hot start	20secs (standard value)
Differential GPS	RX input	SBAS (WAAS, MSAS, EGNOS)
	Ext. input	RTCM SC-104

3.2 Serial data

(1) Format: IEC 61162-1 (NMEA-0183 Ver. 2.0)
*Ver. 1.5 is available on option basis.

(2) Input data

DGPS Input: RTCM SC-104, 4800bps
Parameter settings: KODEN PRIVATE COMMAND, 4800bps
Refer to chapter 5 for details.

(3) Output data

Sentence: GGA, GLL, VTG, RMC, ZDA, GSA, GSV etc.

3.3 Power supply specifications

Input voltage: 10.8 to 31.2 VDC
Power consumption: 1.3 W max.

3.4 Compass safe distance

Standard: 0.2m
Steering: 0.2m

3.5 Operating environment

The main operating environment conditions are stated below.

(1) Temperature, humidity

- Operating temperature: -25 to +55 degrees celcius
- Storage temperature: -40 to +85 degrees celcius
- Maximum humidity: 93 ± 3% (at +40 degrees celcius)

(2) Vibration

The following levels of vibration can be tolerated with no adverse affect on performance.
Ranging from 2 to 5 Hz to 13.2 Hz, oscillation amount ±1mm± 10% (Maximum rate of 7m/s² at 13.2 Hz)
Maximum acceleration of 7m/s² between 13.2 Hz and 60 Hz.

(3) Water resistance

- IPX6 standard (IEC 60945)
- Water resistant type (JISF8001)

3.6 External dimensions and weight

Dimensional diagram: Refer to the diagram below

Weight: 250g (0.55 lb) (Except cable)

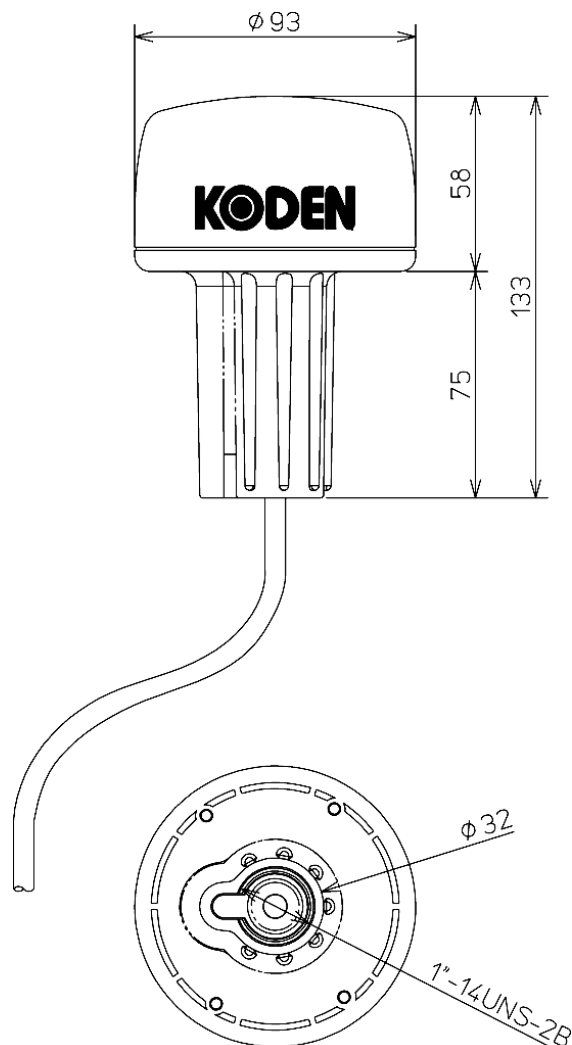

Figure 3.1 GPS-20A external dimensions

Chapter 4 Installation

	Page No.
4.1 Installation precautions.....	4-1
4.2 Unpacking and inspection of the goods.....	4-1
4.3 Installation site.....	4-1
4.4 Installation method	4-3

Chapter 4 Installation

4.1 Installation precautions

The installation of the GPS receiver module should only be carried out by qualified technicians. Installing the GPS receiver module comprises the following actions.

- (1) Unpacking and inspecting the components.
- (2) Checking the power supply voltage and current capacity is rated for the GPS receiver module.
- (3) Determining the installation site.
- (4) Cable laying.
- (5) Installing the GPS receiver module.

4.2 Unpacking and inspection of the goods

Unpack the contents and check each component against the component delivery list. If the contents differ from that which is on the list, or there are damaged components, contact the shipping agent or the nearest KODEN dealer.

4.3 Installation site

Be sure to install the GPS sensor in the highest possible location on the ship for optimum reception of the satellite signal.

Any obstructions in the vicinity of the antenna could result in the loss of the satellite signal reception, positioning time degradation or a reduction in the position accuracy.

- (1) Keep at least 0.5m away from metallic objects.
- (2) Keep at least 4m away from MF/HF L type transmission antennas and VHF or HF whip antennas.
- (3) Keep at least 1.5m away vertically, from MF/HF L type transmission antennas.
- (4) Keep at least 1m away from receive antennas.
- (5) Install away from the ship's radar beam (straight beam angle: 30 – 40 degrees).
- (6) Keep at least 1m away from the ship's Radar antenna.
- (7) Keep at least 5m away from the INMARSAT antenna.
- (8) Keep at least 3m away from loop antennas.
- (9) Keep at least 2m away from the ship's engine.
- (10) Display devices such as cathode ray tubes and LCDs can sometimes interfere with the reception of beacon signals. Keep at least 1m away from display devices such as Plotters, Radars and Sounders.

Refer to Table 1 for the recommended safe installation distances from masts and struts of the ship's super-structure.

Table 1 Minimum distances between support struts

Object	Diameter	Minimum distance
Support strut	10cm	1.5m
Support strut	30cm	3.0m

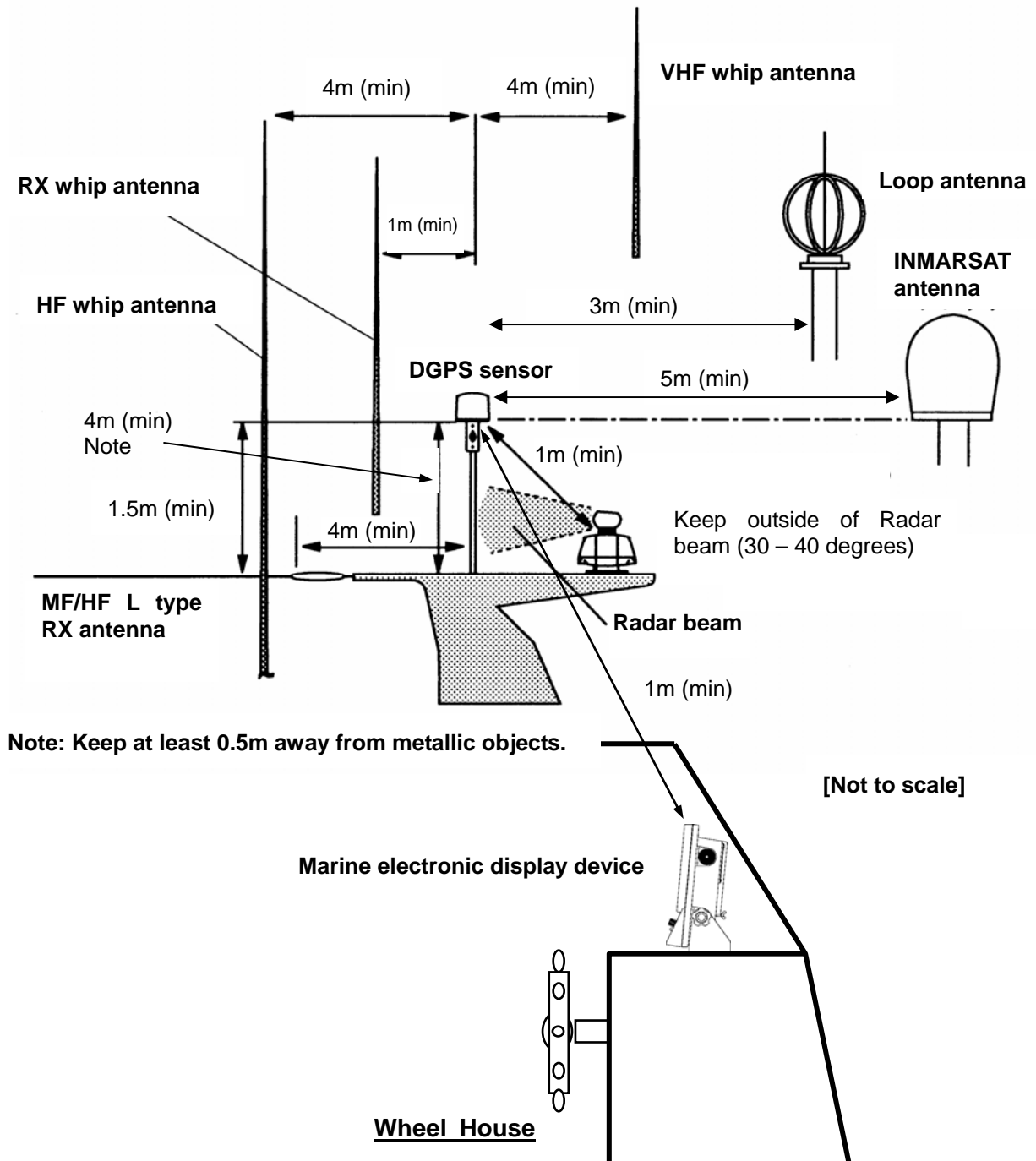

Fig. 4.1 Recommended installation site for the GPS sensor

4.4 Installation method

The following examples show typical installation methods.

Installation example 1: The pole used has no screw thread tooled. Fix the GPS antenna to the pole using the hose band and tighten firmly.

Installation example 2 and 3: The pole used is screw threaded (1-14UNS-2A). In a case when the connecting cable cannot be put through inside the pole, fix the cable at an interval of 30 – 40 cm to the pole using an appropriate tie (See NOTE).

NOTE: A plastic tie is subject to deterioration caused by ultraviolet ray, etc. Use a stainless tie or equivalent, having stable characteristic against the harsh marine environment.

Installation example 1

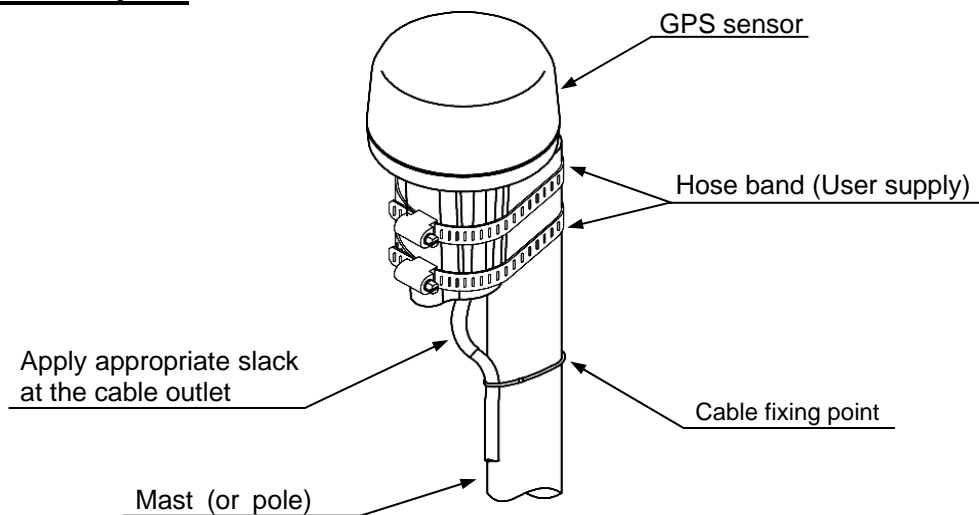

Installation example 2

Keep the cable away from the pole as possible to avoid scratching by the exposed thread.

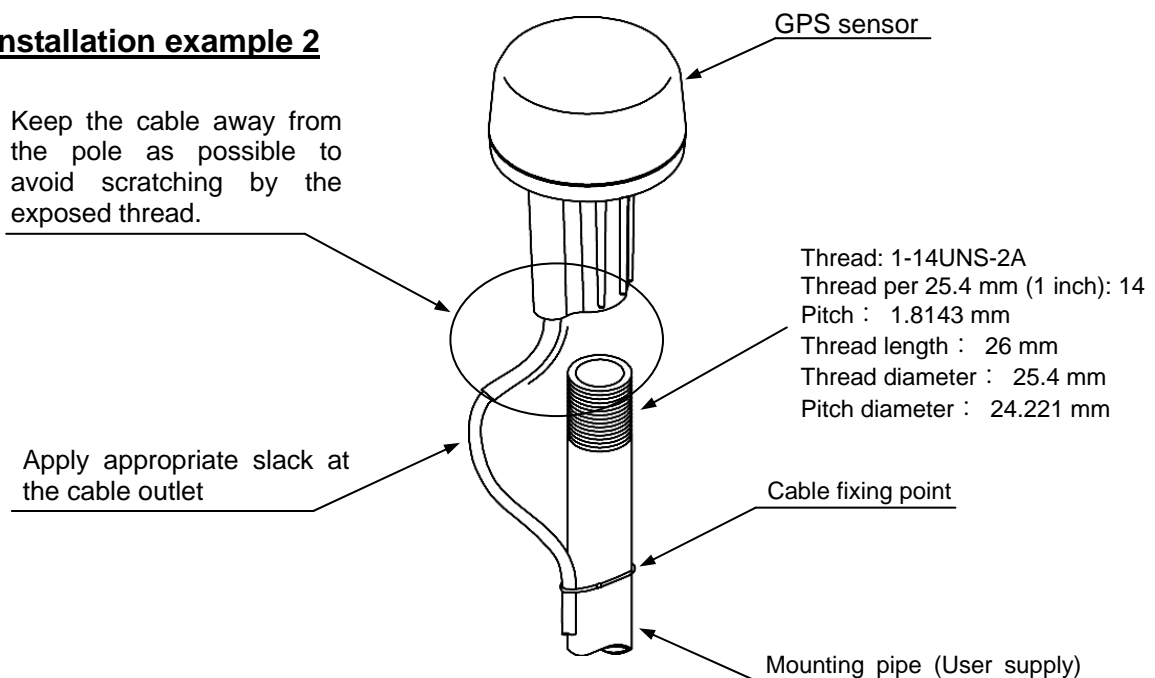

Installation example 3

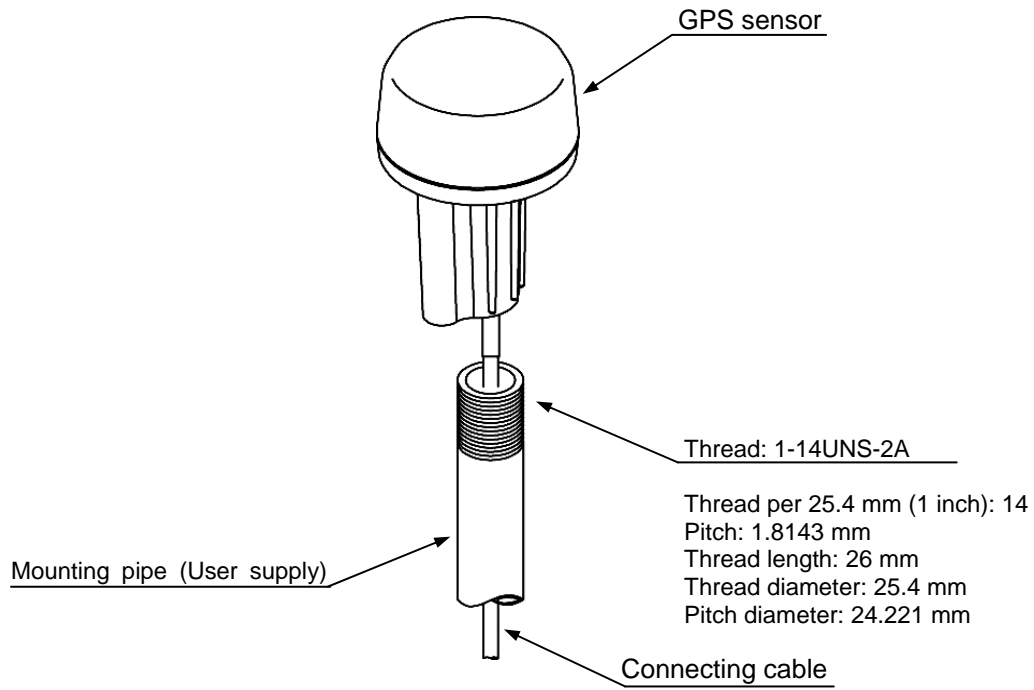

Chapter 5 Technical References

Contents

	Page No.
5.1 Serial input/output data.....	5-1
5.1.1 Input data	5-1
5.1.1.1 Various settings.....	5-1
5.1.1.2 DGPS correction data	5-1
5.1.2 Output data	5-1
5.1.2.1 Format.....	5-1
5.1.2.2 Data form	5-1
5.1.2.3 Data configuration	5-2
5.1.2.4 Output sentence.....	5-2
5.2 Cable connections and connector pin-outs.....	5-4
5.3 Input/Output circuits	5-6
5.3.1 Connections to navigation unit	5-6
5.3.2 Connections to beacon receiver	5-6
5.3.3 GPS-20A input/output circuit.....	5-6
5.4 List of geodetic system	5-7

5.1.2.3 Data configuration

Signal speed	Output voltage level	Output current	Output sentence	Update rate
4800 Baud	RS-422	40mA max	GGA+GLL+VTG+RMC+ZDA PKODA+PKODG,1+PKODG,7 +GSA+GSV	1sec 2secs

5.1.2.4 Output sentence

Note: *hh: Checksum <CR>: Carriage return <LF>: Line feed

GPGGA	GPS Positioning Data
	<p>\$ GP GGA, hhmmss, xxxx.xxxx, N/S, xxxxx.xxxx, E/W, x, xx, xxx.x, 0/- xxxx,</p> <p>M, 0/-xxx, M, xxx, xxxx *hh<CR><LF></p>
GPGLL	Geographic position (latitude/longitude)
	<p>\$ GP GLL, xxxx.xx, N/S, xxxxx.xx, E/W*hh <CR><LF></p>
GPGSA	GPS DOP and active satellites
	<p>\$ GP GSA, A, x, xx, xx, xx, xx, xx, xx, xx, xx, xx, xx, xx, xx, xx, xx, xx, xx, *hh <CR><LF></p> <p>Mode: 1 = fix not available 2 = 2D 3 = 3D</p> <p>PDOP</p>

<p>GPGSV</p>	<p>GPS Satellite in view</p> <p>\$ GP GSV, x, x, xx, xx, xx, xxx, xx,, xx, xx, xxx, xx*hh <CR><LF></p>
<p>GPRMC</p>	<p>Recommended minimum specific GPS data</p> <p>\$ GP RMC, hhmss, A, xxxx.xxx, N/S, xxxx.xxx, E/W, xxx.x, xxx.x, xxxxxx, *hh <CR><LF></p>
<p>GPVTG</p>	<p>Course over ground and ground speed</p> <p>\$ GP VTG, xxx.x, T, , , xxx.x, N, xxx.x, K*hh <CR><LF></p>
<p>GPZDA</p>	<p>Time and Date</p> <p>\$ GP ZDA, hhmss, xx, xx, xxxx, , *hh <CR><LF></p>
<p>PKODA</p>	<p>Satellite Information (KODEN proprietary sentence)</p> <p>\$ PKODA, P/H, xxx.x, xx, xx, xx, xx, xx, xx, xx, xxx, M, xxx.x, N, xxx.x, 0/-xx.x, x, x <CR><LF></p>

<p>PKODG1</p>	<p>Satellite Information (KODEN proprietary sentence)</p> <p>\$ PKODG, 1, x, xx, +/-xx, xxx, xx, xx, xx, xx, xx, xx, xx, xx, xx, xx, xx, <CR><LF></p>
<p>PKODG,7</p>	<p>DGPS Information (KODEN proprietary sentence)</p> <p>\$ PKODG, 7, x, x, xxx <CR><LF></p>

5.2 Cable connections and connector pin-outs

There are 2 types of cables for connecting the GPS-20A to external equipment. One type has a connector and the other does not. Furthermore, there are 4 different types of connector cables as shown below. Each of the connector pin-outs are different so caution is advised.

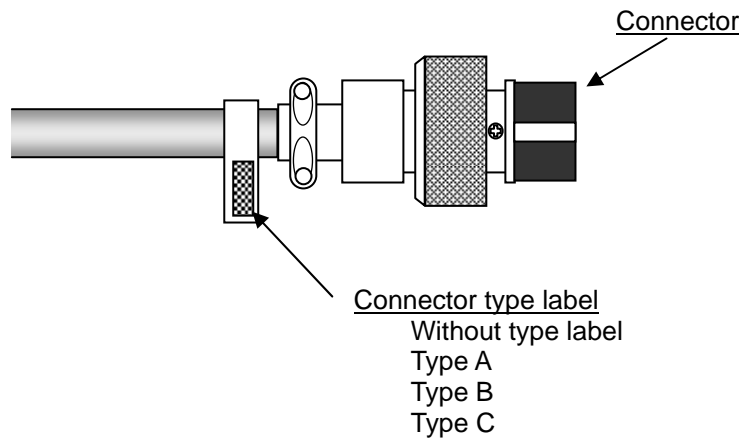

Connecting up without using a connector

* No type name
Cable CW-563-**M (note)

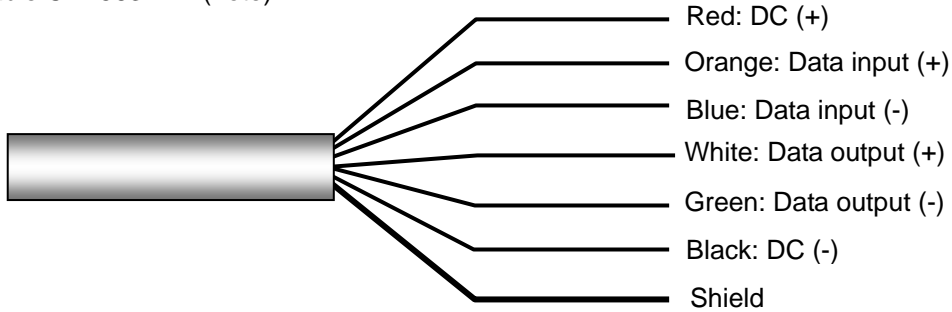

Connecting up using a connector

No type name
Cable CW-563-1-**M
With 6pin connector (1006)

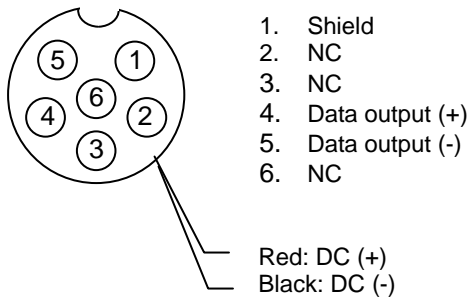

Type A
Cable CW-563-2-**M
With 6pin connector (1006)

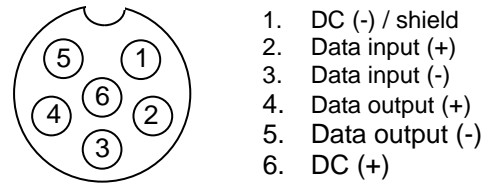

Note: ** field indicates cable length (m)

Type B
Cable CW-563-3-**M
With 6pin connector (LTWBD-06BFFA-L180)

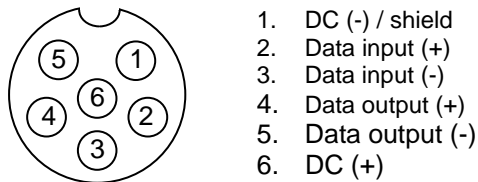

Type C
Cable CW-563-4-**M
With 6pin connector (LTWBD-06BFFA-L180)

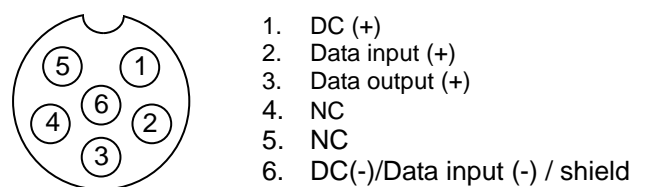

5.3 Input/Output circuits

5.3.1 Navigation unit and connections

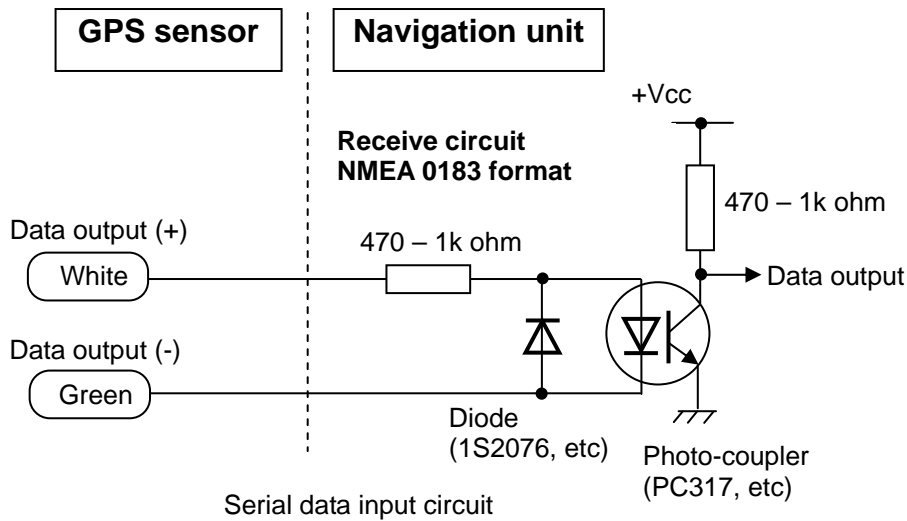

5.3.2 Beacon receiver and connections

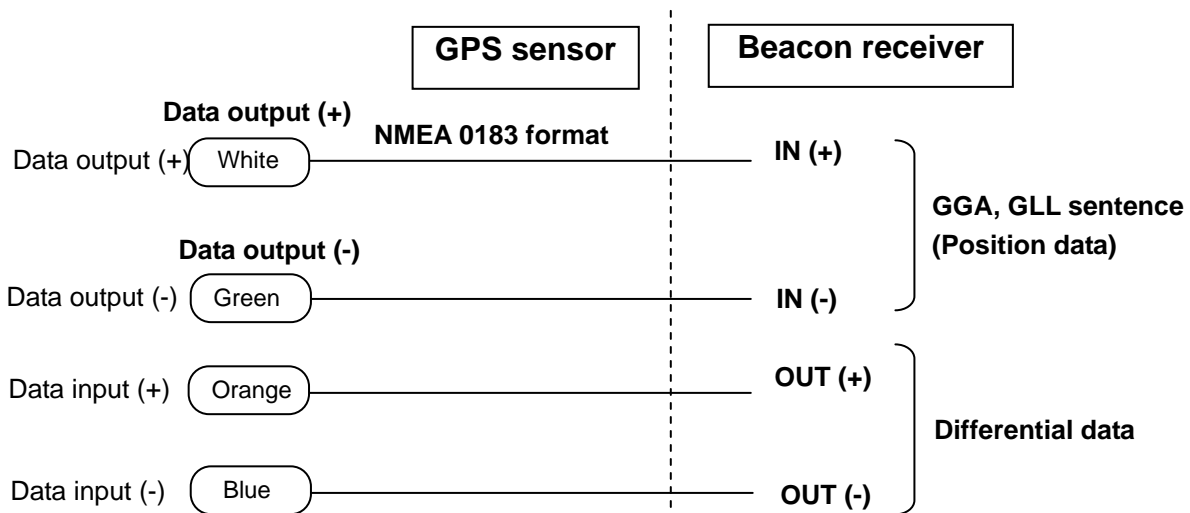

5.3.3 GPS-20A input/output circuit

Serial data input circuit (listener side):

Input load: 600 ohm

Device: Photo-coupler TLP151A (Toshiba)

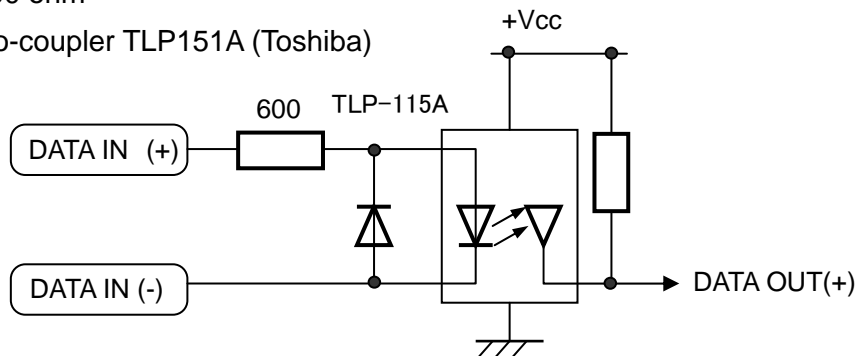

Serial data output circuit (talker side):

Output format: RS422

Driver: HD29050 (Hitachi)

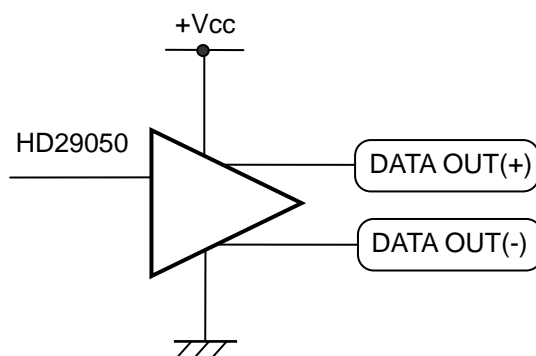

5.4 List of geodetic system

Location	No.	Location	No.	No.	Location	No.	Location
Iceland 1955	11	Tunisia	42	00	WGS-84	43	Chatham
Ireland 1965	12	Diego Garcia	52	01	WGS-72	44	Paraguay
Ascension Islands	31	Tern	33	02	Tokyo	45	Brazil
Alaska / Canada	04	Tokyo	02	03	NAD-27	46	New Georgian I.
Argentina	39	Tristan	80	04	Alaska/Canada	47	Easter Islands
Easter Islands	47	Trinidad/Tobaco	64	05	Europe 1950	48	Maldives
Iwo Islands	32	Nigeria	63	06	Australia 1969	49	Guam 1963
England	20	Japan	24	07	South Asia	50	Guadalcanal
Italy 1940	15	New Zealand	13	08	South America	51	Hong Kong 1963
India / Nepal	18	New Georgian Is..	46	09	Greenland	52	Diego Garcia
Egypt	66	Barren Islands	27	10	NAD-83	53	Johnston Island
Ethiopia / Sudan	25	Bermuda Islands 57	37	11	Iceland 1955	54	Sri Lanka
NAD-27	03	Paraguay	44	12	Ireland 1965	55	Kelguelen
NAD-83	10	Hawaii	21	13	New Zealand	56	Caiman Black Is
Efate	36	East Fauklands 43	76	14	Europe 1979	57	Liberia 1964
Eritrea	60	Pitcairn	69	15	Italy 1940	58	Maha Is. 1971
Australia 1969	06	Fiji Islands	81	16	South America	59	Salvage Island
Oman	67	Phillipines	19	17	Saudi Arabia	60	Eritrea
Caiman Black Is.	56	Finland	84	18	India/Nepal	61	Morocco
Catalonia	72	Faial	78	19	Phillipines	62	Midway
Guadalcanal	50	Phoenix Islands	40	20	England	63	Nigeria
Canary Islands	68	Peurto Rico	71	21	Hawaii	64	Trinidad/Tobaco
Guam 1963	49	Taiwan	85	22	Jakarta	65	Corvo/Flores
Greenland	09	Brazil	45	23	Malaysia/Sing.	66	Egypt
Kenya	30	Brunei/Malaysia	79	24	Japan	67	Oman
Kelguelen	55	Florida/Bahamas	41	25	Ethiopia / Sudan	68	Canary Islands
Cocos Islands	28	Porto Santo/Madeira	77	26	Somalia	69	Pitcairn
Corvo/Flores	65	Hong Kong 1963	51	27	Barren Islands	70	Southern Chile
Colombia	38	Marcus Islands	35	28	Cocos Islands	71	Peurto Rico

Saudi Arabia	17	Marshall Islands	82	29	Zambia/Zimbabwe	72	Catalonia
Salvage Island	59	Maha Island 1971	58	30	Kenya	73	Mascarene
Santa Maria Is.	75	Mascarene	73	31	Ascension Islands	74	Santo Island
Santo Island	74	Malaysia/Singapore	23	32	Iwo Islands	75	Santa Maria Is.
Zambia/Zimbabwe	29	Midway	62	33	Tern	76	East Falklands 43
Jakarta	22	South Asia	07	34	St. Helena Island	77	Porto Santo/Madeira
Johnston Island	53	South America	16	35	Marcus Islands	78	Faial
Sweden	85	South America	08	36	Efate	79	Brunei/Malaysia
Suriname	83	Southern Chile	70	37	Bermuda Is. 57	80	Tristan
Sri Lanka	54	Maldives	48	38	Colombia	81	Fiji Islands
St. Helena Island	34	Morocco	61	39	Argentina	82	Marshall Islands
Somalia	26	Europe 1950	05	40	Phoenix Islands	83	Suriname
WGS-72	01	Europe 1979	14	41	Florida/Bahamas	84	Finland
WGS-84	00	Liberia 1964	57	42	Tunisia	85	Sweden
Chatham	43					86	Taiwan



Koden Electronics Co., Ltd.

Tamagawa Office:

2-13-24 Tamagawa, Ota-ku, Tokyo, 146-0095 Japan

Tel: +81-3-3756-6501 Fax: +81-3-3756-6509

Uenohara Office:

5278 Uenohara, Uenohara-shi, Yamanashi, 409-0112 Japan

Tel: +81-554-20-5860 Fax: +81-554-20-5875

www.koden-electronics.co.jp