

CE 0191 ⓘ

# KODEN

## OPERATION MANUAL

---

### MARINE RADAR

# MDC-2900

## SERIES

This product is specifically designed to be installed on boats and other means of maritime transport. If your country forms part to the EU, please contact your dealer for advice before attempting to install elsewhere.

# **Declaration of Conformity**

(As required by Article 6.3 of Directive 1999/5/EC-RTTE Directive)

Declares under his sole responsibility that the produced Marine Radar System manufactured by

**Koden Electronics Co., Ltd.  
5278 Uenohara  
Uenohara-Shi,  
Yamanashi-Ken  
409-0112  
Japan**

**Telephone +81 554 20 5865**

**Telefax +81 554 20 5880**

Intended for Worldwide use as a Marine Radar for use aboard non-SOLAS vessels and identified by the type number **MDC-2960 / MDC-2910 / MDC-2920** to which this declaration refers has been tested to the essential radio test suites required by the notified body and is in conformity with the standards

**EN 60945 : 2002 ( Clauses 9,10 & 12 )**

**EN 62252 : 2004 ( Clauses 4.8, 4.33, 5.8, 5.33 and Annex D )**

**ITU-R Recommendation RM.1177**

and complies with the essential requirements of Directive 1999/5/EC

Conformity procedure under Annex IV of 1999/5/EC (Technical Construction file) has been undertaken by

**QinetiQ Ltd. Cody Technology Park Ively Road, Farnborough GU14 0LX. United Kingdom**

The Technical Construction File is held by Mr Heinz Hoghoff at

**Koden Elektronik GmbH,  
Am Gewerbepark 15,  
D-64823 Gross-Umstadt / Hessen  
Germany**

**Telephone +49 6078 2056**

**Telefax +49 6078 73824**



**Kenichi Chiwaki, QA Manager.  
Koden Electronics Co., Ltd.  
02 Feb. 2009**

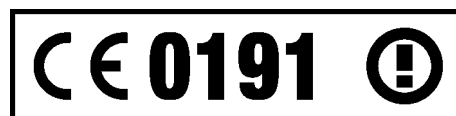

# **Declaration of Conformity**

(As required by Article 6.3 of Directive 1999/5/EC-RTTE Directive)

Declares under his sole responsibility that the produced Marine Radar System manufactured by

**Koden Electronics Co., Ltd.  
5278 Uenohara  
Uenohara-Shi,  
Yamanashi-Ken  
409-0112  
Japan**

**Telephone +81 554 20 5865**

**Telefax +81 554 20 5880**

Intended for Worldwide use as a Marine Radar for use aboard non-SOLAS vessels and identified by the type number **MDC-2960BB / MDC-2910BB / MDC-2920BB** to which this declaration refers has been tested to the essential radio test suites required by the notified body and is in conformity with the standards

**EN 60945 : 2002 ( Clauses 9,10 & 12 )**

**EN 62252 : 2004 ( Clauses 4.8, 4.33, 5.8, 5.33 and Annex D )**

**ITU-R Recommendation RM.1177**

and complies with the essential requirements of Directive 1999/5/EC

Conformity procedure under Annex IV of 1999/5/EC (Technical Construction file) has been undertaken by

**QinetiQ Ltd. Cody Technology Park Ively Road, Farnborough GU14 0LX. United Kingdom**

The Technical Construction File is held by Mr Heinz Hoghoff at

**Koden Elektronik GmbH,  
Am Gewerbepark 15,  
D-64823 Gross-Umstadt / Hessen  
Germany**

**Telephone +49 6078 2056**

**Telefax +49 6078 73824**



**Kenichi Chiwaki, QA Manager.  
Koden Electronics Co., Ltd.  
02 Feb. 2009**

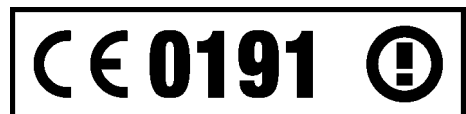

**MDC-2900 Series Operation Manual****Doc No: 0093129012****Document Revision History**

No.	Doc. No.- Rev. No.	Revised Date (Y/M/D)	Revised Content
0	0093129012-00	2009/04/28	First edition
1	0093129012-01	2009/06/05	Full revision
2	0093129012-02	2009/07/24	Full revision
3	0093129012-03	2009/09/25	Chapter 7
4	0093129012-04	2010/01/26	Contents, Chapter 1, Chapter 2, Chapter 4, Chapter 8
5	0093129012-05	2010/04/15	Chapter 1, Chapter 4
6	0093129012-06	2011/11/15	Important Notice, Chapter 2, Chapter 3, Chapter4 TT(ATA)→TT(ARPA)
7	0093129012-07	2013/01/16	Chapter 4, Chapter 7
8			
9			
10			

**Document No. Revised Version Norm**

When part of the document needs to be revised, the document has advanced revision number.

The document No. is indicated at the lower right side on the cover and at the left or right side of the footer region of each page.

© 2009-2013 Kodens Electronics Co., Ltd. All rights reserved.

No part of this publication may be reproduced, transmitted, translated in any from by any means without the written permission of Kodens Electronics Co., Ltd. The technical descriptions contained in this publication are subject to change without notice. Kodens assumes no responsibility for any errors, incidentals or consequential damages caused by misinterpretation of the descriptions contained in this publication.





## Important Notice

- For copy and transcription of this Operation Manual (hereinafter referred to as this manual), permission from Koden is needed. Koden prohibits the un-authorized copy and transcription of this manual.
- If this manual is lost or damaged, consult a dealer of Koden or Koden.
- The specification of the products and the contents in this manual are subject to change without notice.
- The contents displayed on the menu of product may be different from the expression of this manual. The fonts and shapes of the keys and menus in the illustration may differ from the actual ones, and some parts may be omitted.
- Koden is not liable for damages and troubles arisen from misunderstanding of the contents in this manual.
- Koden is not liable for any damages caused by earthquake, lightning, wind and flood damage and fire for which Koden is not responsible, and actions by third parties, other accidents, customer's unintended error/abuse and the use under other abnormal conditions.
- Koden is not liable for damages of accompaniment (change/loss of memorized content, loss of business profit, stop of business) arisen from use or failure of our products.
- If the stored data are changed or lost, irrespective of causes of troubles and damages, Koden is not liable for them.
- Koden is not liable for any damages arisen from malfunction caused by combination of software and connected equipment in which Koden is not engaged.





## For Your Safe Operation

### Symbol used in this Operation Manual

This manual uses the following symbols. Understand the meaning of each symbol and implement the maintenance and inspection.

Symbol	Meaning
 <b>Warning</b>	<b>Mark for warning</b> This symbol denotes that there is a risk of death or serious injury when not dealing with it correctly.
	<b>Mark for danger high voltage</b> This symbol denotes that there is a risk of death or serious injury caused by electric shock when not dealing with it correctly.
 <b>Caution</b>	<b>Mark for caution</b> This symbol denotes that there is a risk of slight injury or damage of device when not dealing with it correctly.
	<b>Mark for prohibition</b> This symbol denotes prohibition of the specified conduct. Description of the prohibition is displayed near the mark.
<b>IMPORTANT</b>	<b>Mark for important matters</b> This mark denotes that there is a possibility that data loss may interfere the operation or that the expected result may not be obtained when the radar is not dealt correctly.
	<b>Mark for reference</b> This mark shows the part to be referred to concerning this description.

**Caution Item on Equipment**





	<p><b>Caution on a high voltage inside.</b></p> <p>A high voltage, which may risk your life, is used. This high voltage remains in the circuit after you have powered off switch. To prevent touching the high voltage circuit inadvertently, the protective cover is provided to the high voltage circuit and the high voltage caution label is affixed. Ensure to power off switch for your safety and discharge the electricity remaining in the capacitor before starting to check. An engineer authorized by our company should inspect and maintain the circuit.</p>
 <p><b>Warning</b></p>	<p><b>Be sure to switch off the power in the boat.</b></p> <p>If the power switch is inadvertently powered on during work, you will be electrified. To prevent such accident from occurring, ensure to switch off the power in the boat and the power of equipment. Furthermore, it is safer to hang the caution tag with description of [Under Work] near the power switch of equipment.</p>
 <p><b>Warning</b></p>	<p><b>Caution on dust</b></p> <p>Inhaling dust may cause A respiratory disease. When cleaning the inside of equipment, be careful not to inhale dust. Wearing a safety mask is recommended.</p>
 <p><b>Caution</b></p>	<p><b>Caution on location of equipment</b></p> <p>Do not install the equipment where it is excessively damp and suffers from excessive water drops.</p>
 <p><b>Caution</b></p>	<p><b>Caution on static electricity</b></p> <p>The static electricity may be generated from the carpet on the floor in the cabin or clothes made of synthetic fiber. The static electricity may destroy the electronic parts on the circuit board. Handle the circuit board, taking the suitable anti-static measures.</p>

**Caution Item on Handling**

 <p><b>Caution</b></p>	<p><b>Caution on the rotating aerial</b></p> <p>The radar antenna may start to rotate without notice. Please stand clear from the antenna for your safety.</p>
---	--

 <p><b>Caution</b></p>	<p><b>Caution on electromagnetic disturbance</b></p> <p>The operating antenna &amp; scanner unit radiates high-energy electromagnetic wave. It may cause harmful effect for human body due to its continuous irradiation. As International regulation says, electromagnetic waves less than 100 watt/m<sup>2</sup> does not have a harmful effect on human bodies, but some kind of medical devices such as heart pacemakers are sensitive even under the low energy electromagnetic wave. Any personnel with such a device should keep away from the electromagnetic wave generating position at all times.</p> <p>Specified power density and distance from the radar (in accordance with the provision as specified in IEC 60945)</p> <table border="1" style="width: 100%; border-collapse: collapse;"> <thead> <tr> <th style="text-align: left;">Model name</th> <th style="text-align: left;">Xmit power/ Antenna length</th> <th style="text-align: center;">100W/m<sup>2</sup></th> <th style="text-align: center;">50W/m<sup>2</sup></th> <th style="text-align: center;">10W/m<sup>2</sup></th> </tr> </thead> <tbody> <tr> <td>MDC-2960</td> <td>6kW / 4 feet Antenna</td> <td style="text-align: center;">1.09m</td> <td style="text-align: center;">1.55m</td> <td style="text-align: center;">3.46m</td> </tr> <tr> <td>MDC-2960BB</td> <td>6kW / 6 feet Antenna</td> <td style="text-align: center;">1.30m</td> <td style="text-align: center;">1.84m</td> <td style="text-align: center;">4.11m</td> </tr> <tr> <td>MDC-2910</td> <td>12kW / 4 feet Antenna</td> <td style="text-align: center;">1.55m</td> <td style="text-align: center;">2.19m</td> <td style="text-align: center;">4.89m</td> </tr> <tr> <td>MDC-2910BB</td> <td>12kW / 6 feet Antenna</td> <td style="text-align: center;">1.84m</td> <td style="text-align: center;">2.60m</td> <td style="text-align: center;">5.81m</td> </tr> <tr> <td>MDC-2920</td> <td>25kW / 4 feet Antenna</td> <td style="text-align: center;">2.37m</td> <td style="text-align: center;">3.36m</td> <td style="text-align: center;">7.50m</td> </tr> <tr> <td>MDC-2920BB</td> <td>25kW / 6 feet Antenna</td> <td style="text-align: center;">2.82m</td> <td style="text-align: center;">3.99m</td> <td style="text-align: center;">8.91m</td> </tr> </tbody> </table>	Model name	Xmit power/ Antenna length	100W/m <sup>2</sup>	50W/m <sup>2</sup>	10W/m <sup>2</sup>	MDC-2960	6kW / 4 feet Antenna	1.09m	1.55m	3.46m	MDC-2960BB	6kW / 6 feet Antenna	1.30m	1.84m	4.11m	MDC-2910	12kW / 4 feet Antenna	1.55m	2.19m	4.89m	MDC-2910BB	12kW / 6 feet Antenna	1.84m	2.60m	5.81m	MDC-2920	25kW / 4 feet Antenna	2.37m	3.36m	7.50m	MDC-2920BB	25kW / 6 feet Antenna	2.82m	3.99m	8.91m
Model name	Xmit power/ Antenna length	100W/m <sup>2</sup>	50W/m <sup>2</sup>	10W/m <sup>2</sup>																																
MDC-2960	6kW / 4 feet Antenna	1.09m	1.55m	3.46m																																
MDC-2960BB	6kW / 6 feet Antenna	1.30m	1.84m	4.11m																																
MDC-2910	12kW / 4 feet Antenna	1.55m	2.19m	4.89m																																
MDC-2910BB	12kW / 6 feet Antenna	1.84m	2.60m	5.81m																																
MDC-2920	25kW / 4 feet Antenna	2.37m	3.36m	7.50m																																
MDC-2920BB	25kW / 6 feet Antenna	2.82m	3.99m	8.91m																																



 <b>Warning</b>	Do not disassemble or modify. It may lead to trouble, fire, smoking or electric shock. In case of trouble, contact our dealer or our company.
 <b>Warning</b>	In case of smoke or fire, switch off the power in the boat and the power of equipment. It may cause fire, electric shock or damage.
	Caution on the remaining high voltage. A high voltage may remain in the capacitor for several minutes after you have powered off. Before inspecting inside, wait at least 5 minutes after powering off or discharging the remaining electricity in an appropriate manner. Then, start the work.
 <b>Caution</b>	The information displayed in this unit is not provided directly for your navigation. For your navigation, be sure to see the specified material.
 <b>Caution</b>	Use the specified fuse. If un-specified fuse is used, it may cause a fire, smoke or damage.

**Disposal of used cell and this radar****Warning**

A high-energy density lithium ion cell is built in this radar.

Improper disposal of a lithium ion cell is discouraged as the cell has a possibility of short-circuiting. If it gets wet, the generation of heat, explosion or ignition may occur resulting in an injury or a fire.

**Treatment of the used lithium ion cell**

To dispose of built-in lithium ion cell (CR-2032) in this radar, insulate each terminal with scotch tape, etc. and wrap in plastic bag, etc.

The disposal and collection rules may be different depending on each municipal district. Obey the directions of each district.

**Disposal of this radar**

This radar shall be disposed according to the municipal regulations or rules.

## Contents

Document Revision History.....	i
Important Notice.....	ii
For Your Safe Operation.....	iii
Disposal of used cell and this radar.....	vii
Contents.....	viii
Introduction.....	xvi
Configuration items.....	xvii
System configuration.....	xvii
Option.....	xviii
<b>Chapter 1 Adjustment in installation.....</b>	<b>1-1</b>
<b>1.1 Menu usage.....</b>	<b>1-1</b>
<b>1.2 Tuning method.....</b>	<b>1-1</b>
Auto tuning.....	1-1
Manual tuning.....	1-1
<b>1.3 Picture bearing adjustment (HL OFFSET).....</b>	<b>1-2</b>
<b>1.4 Adjustment of transmitting delay time (TX DELAY).....</b>	<b>1-3</b>
<b>1.5 Setup antenna height.....</b>	<b>1-4</b>
<b>1.6 Setup antenna cable length.....</b>	<b>1-4</b>
<b>1.7 Setup of MBS (Main Bang Suppression) value.....</b>	<b>1-4</b>
<b>1.8 Setup own ship profile (Cannot use on transmitting).....</b>	<b>1-5</b>
<b>1.9 Inside save of setup data at the time of setting up (Cannot use while transmitting).....</b>	<b>1-6</b>
<b>1.10 External save of setup (Cannot use on transmitting).....</b>	<b>1-10</b>
<b>Chapter 2 Basic operation [for operating unit (panel)].....</b>	<b>2-1</b>
<b>2.1 Illustration of operating unit (panel).....</b>	<b>2-1</b>
<b>2.2 Name of radar display.....</b>	<b>2-2</b>
<b>2.3 Power On/Off.....</b>	<b>2-4</b>
Power On.....	2-4
Power Off.....	2-4
<b>2.4 Change brilliance of display unit.....</b>	<b>2-5</b>
Change display brilliance.....	2-5
Change lighting of operating panel illumination.....	2-5
<b>2.5 Transmission.....</b>	<b>2-5</b>
Start transmission.....	2-5
Stop transmission.....	2-5
<b>2.6 Change range (indicated distance).....</b>	<b>2-6</b>

	*About bearing scale .....	2-6
<b>2.7</b>	<b>Adjust receiver gain (GAIN)</b> .....	2-7
<b>2.8</b>	<b>Reject sea clutter (anti-SEA)</b> .....	2-8
	Selection of MAN SEA and AUTO SEA .....	2-8
	AUTO adjustment of the SEA .....	2-9
	Manual adjustment of the SEA.....	2-9
<b>2.9</b>	<b>Reject rain/snow clutter (anti-RAIN)</b> .....	2-10
	Changing method of CFAR and DIFF .....	2-10
	CFAR (Constant False Alarm Rate) adjustment .....	2-11
	RAIN DIFF (Differentiation) adjustment .....	2-12
<b>2.10</b>	<b>Change transmission pulse length (SP/LP)</b> .....	2-13
<b>2.11</b>	<b>Measure distance and bearing of a target</b> .....	2-14
	Measure distance (VRM: Variable Range Maker).....	2-14
	Measure bearing (EBL: Electronic Bearing Line).....	2-15
	Using the EBL based on a position other than reference point (EBL OFFSET) ....	2-16
	Measure distance/bearing (PI: Parallel index line).....	2-17
	Measure distance/bearing (ERBL: Electronic range and bearing line).....	2-20
<b>2.12</b>	<b>Change display color (Day/Night)</b> .....	2-21
<b>2.13</b>	<b>Remove the heading line</b> .....	2-21
<b>2.14</b>	<b>Relocate antenna position (Off-centering)</b> .....	2-22
<b>2.15</b>	<b>Select screen display (Display mode)</b> .....	2-23
	For H UP (Head up mode) .....	2-23
	For C UP (Course up mode) .....	2-24
	For N UP (North up mode) .....	2-24
	For relative motion (RM) and true motion (TM).....	2-25
	Reset true motion.....	2-26
<b>2.16</b>	<b>F (Function key) usage</b> .....	2-27
<b>Chapter 3 Primary operations (For menu)</b> .....		3-1
<b>3.1</b>	<b>Menu usage</b> .....	3-1
	Display and remove menu .....	3-1
	Select menu item .....	3-1
<b>3.2</b>	<b>STAB MODE</b> .....	3-2
	SEA (Sea stabilization).....	3-2
	GND (Ground stabilization).....	3-3
<b>3.3</b>	<b>Radar signal correlation (PROCESS)</b> .....	3-4
<b>3.4</b>	<b>Enhance target (ENH)</b> .....	3-6
<b>3.5</b>	<b>Interference rejection (IR)</b> .....	3-7
<b>3.6</b>	<b>Video mode (VIDEO)</b> .....	3-8

<b>3.7</b>	<b>Display ship's trail</b> .....	3-9
	Relative display (R) .....	3-10
	True display (T) .....	3-10
<b>3.8</b>	<b>Display range rings (RR)</b> .....	3-11
<b>3.9</b>	<b>Bearing mode set up</b> .....	3-12
<b>3.10</b>	<b>Echo alarm</b> .....	3-13
<b>3.11</b>	<b>Target tracking TT (ARPA) / AIS common items</b> .....	3-15
	VECTOR.....	3-15
	CPA/TCPA.....	3-16
	TGT ID .....	3-16
	PAST POSN: Past position.....	3-17
	ASSOCIATION .....	3-18
	Setup area .....	3-19
	INPUT RNG: Input range.....	3-21
	AUTO ACQ AREA: Automatic acquisition area .....	3-22
	GUARD ZONE.....	3-23
<b>3.12</b>	<b>Target tracking TT (ARPA)</b> .....	3-24
	Enable TT (ARPA) function .....	3-24
	Manual acquisition.....	3-24
	Delete target.....	3-25
	Delete all targets.....	3-25
	Reference target acquisition.....	3-26
	Types of tracked target symbol .....	3-27
	TEST TGT .....	3-28
<b>3.13</b>	<b>AIS</b> .....	3-38
	Enable AIS function .....	3-38
	Setup operation area .....	3-38
	ACTIVE / SLEEP .....	3-39
	FILTER [Sleep targets only].....	3-39
	AIS AUTO ACQ .....	3-39
	Types of AIS target symbol.....	3-40
<b>3.14</b>	<b>Trial manoeuvre</b> .....	3-41
<b>Chapter 4 General operation (Menu)</b> .....		4-1
<b>4.1</b>	<b>RADAR</b> .....	4-1
	TUNE MAN ADJ .....	4-1
	TRAIL TRUE / REL.....	4-1
	TRAIL TIME .....	4-1
	TRAIL SHAPE .....	4-1

	TRAIL DETECT LEVEL.....	4-1
	TRAIL RESET .....	4-1
	OFF CENT POINT .....	4-1
	AUTO OFF CENT .....	4-1
	TM RESET .....	4-2
	C UP RESET .....	4-2
	DETAIL .....	4-2
<b>4.2</b>	<b>ALARM</b> .....	4-6
	ECHO ALARM.....	4-6
	ECHO ALARM MODE.....	4-6
	ECHO ALARM DETECT LEVEL.....	4-6
	MAP AREA.....	4-6
	MAP AREA DETECT LEVEL .....	4-6
	CPA/ TCPA.....	4-6
	AUTO ACQ.....	4-6
	GZ .....	4-6
	AIS SLEEPING LOST.....	4-6
	AIS NO HDG / COG.....	4-7
	NAVLINE CROSS .....	4-7
	PRIORITY .....	4-7
	LIST.....	4-8
	HISTORY LIST.....	4-8
	DETAIL .....	4-9
<b>4.3</b>	<b>OS / TGT</b> .....	4-10
	VECT TRUE/REL .....	4-10
	VECT TIME .....	4-10
	VECT TIME INCREMENT.....	4-10
	TGT ID DISP .....	4-10
	ID DISP SIZE .....	4-10
	INTPUT RNG .....	4-10
	ASSOCIATION.....	4-10
	CHANGE SELECTED TGT.....	4-10
	SETTING.....	4-10
	AUTO ACQ AREA .....	4-10
	STAB INDICATOR.....	4-11
	ANT POSN .....	4-11
	PAST TRK TIME.....	4-12
	PAST TRK TIME INCREMENT .....	4-13
	PAST TRK RESET .....	4-13

	STERN LINE .....	4-13
	SHIP OUTLINE.....	4-14
	AIS.....	4-14
	SELECT ID .....	4-14
	ACTIVE / SLEEP .....	4-14
	LABEL .....	4-14
	SHIP OUTLINE.....	4-14
	HDG LINE.....	4-14
	TURN INDICATOR.....	4-14
	CLASS B .....	4-15
	ATON .....	4-15
	SAR (Search and rescue aircraft) .....	4-15
	BASE .....	4-15
	OS DISP .....	4-15
	MESSAGE DISP .....	4-15
	TT .....	4-16
	SELECT ID .....	4-16
	ACQ.....	4-16
	DELETE.....	4-16
	ALL DELETE .....	4-16
	REF ACQ.....	4-16
	EDIT NAME .....	4-16
	TEST TGT .....	4-16
	TRIAL MANOEUVRE .....	4-17
	DETAIL .....	4-17
<b>4.4</b>	<b>TOOL</b> .....	4-20
	RR .....	4-20
	BRG TRUE/REL .....	4-20
	CURSOR SHAPE.....	4-20
	PI LINE .....	4-20
	PI LINE DISP.....	4-20
	PI LINE START RNG.....	4-20
	PI LINE END RNG.....	4-20
	PI DISP SIDE .....	4-20
	EBL1 OFFSET.....	4-21
	EBL2 OFFSET.....	4-21
	DETAIL .....	4-22
<b>4.5</b>	<b>MAP</b> .....	4-25
	DISP .....	4-25

DISP GROUP .....	4-25
DISP GROUP COAST LINE .....	4-25
DISP GROUP NAV LINE.....	4-26
DISP GROUP ROUTE (Alternate planned route) .....	4-26
DISP GROUP EVENT MARK .....	4-26
DISP GROUP AREA .....	4-27
EDIT COAST LINE.....	4-27
EDIT NAV LINE .....	4-27
EDIT ROUTE (Alternate planned route) .....	4-28
EDIT EVENT MARK.....	4-28
EDIT AREA.....	4-28
MONITORED ROUTE.....	4-28
WPT ID DISP .....	4-29
DATUM.....	4-29
EDIT USER DATUM.....	4-29
POSITION OFFSET .....	4-29
MAN OFFSET .....	4-29
DETAIL .....	4-29
<b>4.6 BRILL</b> .....	4-34
COLOR.....	4-34
COLOR ECHO .....	4-34
COLOR TRAIL .....	4-34
COLOR BKGND PPI.....	4-34
COLOR BKGND DATA.....	4-34
COLOR DATA .....	4-34
BRIGHTNESS .....	4-34
DETAIL .....	4-35
<b>4.7 SYSTEM</b> .....	4-37
INTER SWITCH (Cannot use while transmitting) .....	4-37
TIME.....	4-38
ASSISTANT DISP .....	4-39
TGT LIST SORT.....	4-40
USER .....	4-40
EDIT USER NAME.....	4-40
SOUND .....	4-40
FREQUENCY.....	4-40
KEY CLICK.....	4-40
BITE .....	4-41
TOTAL HOUR.....	4-41



	TX HOUR .....	4-41
	VERSION .....	4-41
	DETAIL .....	4-42
<b>4.8</b>	<b>MAINTENANCE</b> .....	<b>4-43</b>
	START UP .....	4-43
	I / O .....	4-44
	DETAIL .....	4-46
	OS PROFILE (Cannot use while transmitting) .....	4-47
	SECTOR MUTE (Cannot use while transmitting) .....	4-48
	PRESET .....	4-49
	BACKUP (Cannot use while transmitting) .....	4-53
	TOTAL HOUR (Cannot use while transmitting) .....	4-53
	TX HOUR (Cannot use while transmitting) .....	4-53
<b>4.9</b>	<b>Menu configuration</b> .....	<b>4-54</b>
<b>Chapter 5</b>	<b>Specification</b> .....	<b>5-1</b>
<b>5.1</b>	<b>Antenna and Scanner</b> .....	<b>5-1</b>
<b>5.2</b>	<b>Display unit and processor unit</b> .....	<b>5-2</b>
<b>5.3</b>	<b>External view and dimensions</b> .....	<b>5-3</b>
<b>Chapter 6</b>	<b>Principle of radar system</b> .....	<b>6-1</b>
<b>6.1</b>	<b>What is radar system?</b> .....	<b>6-1</b>
	Side lobe .....	6-1
	Beam width .....	6-2
<b>6.2</b>	<b>Characteristics of radar radio wave</b> .....	<b>6-2</b>
	Target hardness reflected .....	6-2
	Radar shadow .....	6-3
	False image .....	6-3
<b>6.3</b>	<b>Radar interference</b> .....	<b>6-5</b>
<b>6.4</b>	<b>Receiving the Radar Beacons, SART and Radar Enhancer</b> .....	<b>6-6</b>
<b>Chapter 7</b>	<b>Simple fault diagnostics</b> .....	<b>7-1</b>
<b>7.1</b>	<b>No alarm sound (ALARM TEST)</b> .....	<b>7-2</b>
<b>7.2</b>	<b>Operation unit (panel) key is not operational (PANEL TEST)</b> .....	<b>7-3</b>
<b>7.3</b>	<b>TT (ARPA) is not operational (DIAGNOSE TT)</b> .....	<b>7-4</b>
<b>7.4</b>	<b>No AIS display (DIAGNOSE AIS)</b> .....	<b>7-5</b>
<b>7.5</b>	<b>Need to confirm serial input (SERIAL MONITOR)</b> .....	<b>7-6</b>
<b>7.6</b>	<b>No video display (ANT MONITOR)</b> .....	<b>7-7</b>
<b>7.7</b>	<b>Screen is frozen</b> .....	<b>7-8</b>

<b>7.8</b>	<b>About alarms</b> .....	7-9
	Alarm list.....	7-11
	Warning list.....	7-13
<b>Chapter 8</b>	<b>Index</b> .....	8-1

## Introduction

The MDC-2900 series is a compact and high performance shipboard radar system consisting of the antenna & scanner unit with a transmit power of 6kW/12kW/25kW, a display unit with a 19 inch color LCD (Liquid Crystal Display) display and operating panel unit.

For this radar, its multi functions and high performance are accomplished with microcomputer technology as well as an image processing in the newly developed radar-dedicated LSI (Large Scale Integration).

- A slim display unit using liquid crystal technology.
- Stable indication and reliable acquisition of a small target.
- Clear distinction between a moving target and land by true trail display.
- Provision of multi targets TT (ARPA) information and the chart display (mandatory or optional).
- Various models for selection of an optimum radar for your needs.
- Simple and easy operation by user-friendly rotating knobs.
- Capable of adjusting gain, anti- sea clutter, anti- rain clutter, bearing cursor, and range marker, etc. using rotating knobs.
- The waterproof operating panel (IPX2) has a great flexibility in installation.

## Configuration items

### System configuration

#### MDC-2960/2910/2920

No.	Name	Type
1	Antenna	*
2	Scanner	**
3	Display unit	MRD-105
4	Operation unit with connecting cable	MRO-105
5	Connecting cable	242J159098B-15M
6	DC power cable	CW-259-2M
7	Spare parts	SP-100
8	Installation material	M12-BOLT.KIT
9	Installation material	CONNECTOR.KIT
10	Operation manual	0093129012
11	Installation manual	0092629012
12	Quick reference	0093129042

\* RW701A-04: 4feet, RW701A-06: 6feet

\*\* RB717A: 6kW (MDC-2960), RB718A: 12kW (MDC-2910), RB719A: 25kW (MDC-2920)

#### MDC-2960BB/2910BB/2920BB

No.	Name	Type
1	Antenna	*
2	Scanner	**
3	Processor unit	MRM-105
4	Operation unit with connecting cable	MRO-105
5	Connecting cable	242J159098B-15M
6	DC power cable	CW-259-2M
7	Spare parts	SP-100
8	Installation material	M12-BOLT.KIT
9	Installation material	CONNECTOR.KIT
10	Operation manual	0093129012
11	Installation manual	0092629012
12	Quick reference	0093129042

\* RW701A-04: 4feet, RW701A-06: 6feet

\*\* RB717A: 6kW (MDC-2960BB), RB718A: 12kW (MDC-2910BB), RB719A: 25kW (MDC-2920BB)

## Option

---

No.	Name	Type	Comment
1	Gyro Interface	S2N, U/N 9028C	Gyro converter
2	Gyro Log Interface	NCT-4106	CFQ-6998 attached.
3	Log pulse NMEA converter	L1N, U/N 9181A	200pulse/NM only
4	Rectifier unit	PS-010	5A fuse attached. For 4 or 6 foot antenna only.
5		VL-PGS001	20A fuse attached. For 9 foot antenna only.
6	AC power cable	VV-2D8-3M	Without a connector on the both sides
7	Connecting cable	CW-373-*	With 6 pin-waterproof connector on the both sides (cable for data)
8		*: 5M, 10M, 30M	
9		CW-374-5M	With 6 pin-waterproof/6 pin (1006 series) (cable for data)
10		CW-376-5M	6 pin-waterproof/left unattended (cable for data)
11		CW-387-5M	8 pin-waterproof/left unattended (cable for AIS)
12		CW-406-5M	8 pin-waterproof/left unattended (cable for HDG input)
13		CW-561-*	With a connector on the both sides (connector for slave display)
14		*: 10M, 30M	
15	Antenna unit –	CW-576-0.5M	10 pin- waterproof /D-SUB(female) + Alarm out
16	Display unit	CW-560-2M	With D-SUB on the both sides Cable for external display unit
17	connecting cable	242J159098C-20M	With a connector on the both sides
		242J159098D-30M	With a connector on the both sides
		242J159098E-XM	With a connector on the both sides
		X: 65m max	

## Chapter 1 Adjustment in installation

### 1.1 Menu usage

 Refer to “Menu usage” (page3-1)

\*About the shaded menu:

[Inters witch] in [System] menu, and [Sector mute], [Backup], [Transmission time] and [Operating time] in [Maintenance] menu are not available during transmission, and they are all shaded.

### 1.2 Tuning method

The transmitted and received frequency of this radar may become detuned by environmental changes. This results in “detuning” of the gain and the same image may be hard to be seen, even if the setup is the same as before.

[Tuning method] can be changed directly in the upper light of the screen, with trackball and [ENT] key, without using menu function.

#### Auto tuning

---

This function automatically compensates detune caused by environmental changes.

Sometimes, as auto tuning adjusts to optimize strong echo, weak echo may be weakened too much when strong echo such as from land is received.

Adjust [AUTO ADJ] to optimize value if echo from the object target is weak.

[MENU] => [MAINTENANCE] => [STARTUP] => [TUNE AUTO ADJ]

#### Manual tuning

---

Perform all adjustments manually.

[MAN ADJ] adjustment is required whenever detuning is caused by environmental changes.

[MENU] => [MAINTENANCE] => [STARTUP] => [TUNE MAN ADJ]

[MENU] => [RADAR] => [TUNE AUTO ADJ]

Optimized value setup method

Adjustment shall be performed based on stable echo object such as from land. (Land is used in following explanation.)

- 1 Set “RAIN” and “SEA” to 0.
- 2 Weaken Gain until land echo is nearly disappears.
- 3 Press [MENU] key, select [MAINTENANCE] => [STARTUP] =>.
- 4 Adjust [AUTO ADJ] or [MAN ADJ] to get the strongest land echo.
- 5 Repeat step 2 to 4 then adjustment is completed.

### 1.3 Picture bearing adjustment (HL OFFSET)

The bearing on the radar screen is adjusted.

- 1** Change the range scale to 1 NM or more by pressing “+” (or “-”) key on the transmission display.
- 2** Select a visible fixed object as far as possible and measure its bearing using magnetic compass or equivalence. Measure the bearing of the same target on the radar screen. Adjust it according to the following procedures when both values differ one degree or more.
- 3** Press [MENU] key to display menu, select [MAINTENANCE] => [STARTUP] => [HL OFFSET] => VALUE and indicate the last digit of the input value by highlighted character.
- 4** Move a trackball up or down to adjust the value to match the bearing value of the target picture to the compass value.
- 5** Press [ENT] key to determine adjustment result.

## 1.4 Adjustment of transmitting delay time (TX DELAY)

This adjustment is intended to match the picture on a radar window with the distance of an actual target through adjustment of the transmission delay time. For the purpose of accurate adjustment, a hard, long, straight object such as a quay wall extended on a near (within about 100m) position is utilized to produce good result. Transmitting delay time is adjusted in accordance with the following procedures.

- 1 Change the range scale to 0.125 NM by pressing “+” (or “-”) key on the transmission display.
- 2 Press [MENU] key to display menu, select [MAINTENANCE] => [STARTUP] => [TX DELAY] =>.
- 3 Move a trackball up or down to adjust the value to get a straight picture of the straight object in the screen as shown in follow image.
- 4 Press [ENT] key to determine adjustment result.

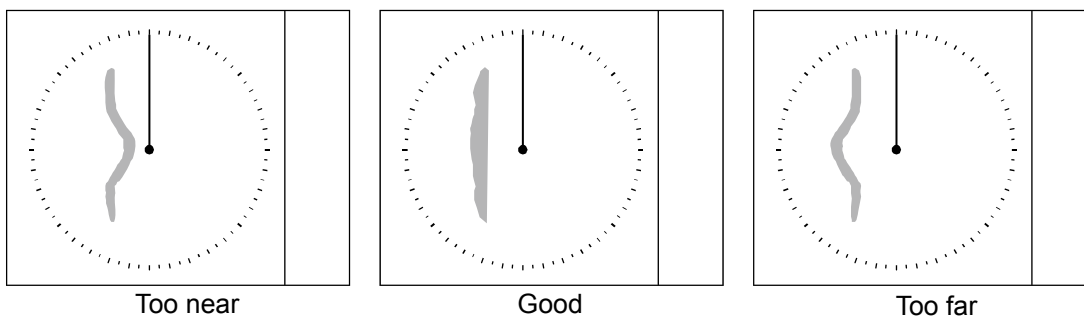



## 1.5 Setup antenna height

Set up antenna installation height from sea level.

Effect of anti sea-clutter varies depending on the above setup.

- 1 Press [MENU] key to display "Menu".  
Select [MAINTENANCE] => [STARTUP] => [ANT HEIGHT] => and press [ENT] key after selecting the setup value.

## 1.6 Setup antenna cable length

Set up antenna cable length.

Improper setting of antenna cable length may result in degraded target detection.

- 1 Press [MENU] key to display "Menu".  
Select [MAINTENANCE] => [STARTUP] => [ANT CABLE] => and press [ENT] key after selecting the setup value.

## 1.7 Setup of MBS (Main Bang Suppression) value

This setting is utilized to suppress (mute) transmitting leak of small dark circle spot signal at the center of the display.

- 1 Set range to 0.125 NM, RAIN knob to 0, SEA knob to 0, GAIN knob to 80%, and brilliance to maximum respectively.

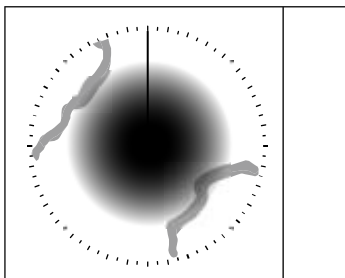

- 2 Press [MENU] key to display "Menu".  
Select [MAINTENANCE] => [STARTUP] => [MBS] => Value by highlighted character using trackball.
- 3 Turn sea knob to display transmitting leak circle at the center of the picture.

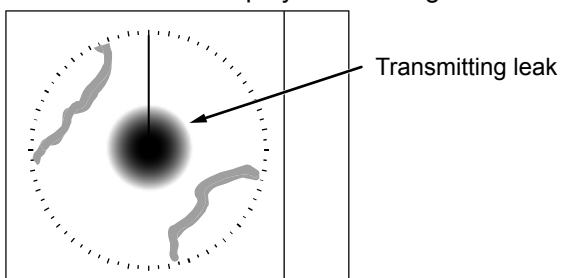

- 4 Move a trackball up or down to increase MBS value from zero with observing the center circle.  
Press [ENT] key to determine when the circle has just faded out.

## 1.8 Setup own ship profile (Cannot use on transmitting)

Set up own ship outline.

Set up antenna location from CCRP (Consistent common reference point).

**1** Press [MENU] key to display "Menu".

Select [MAINTENANCE] => [OS PROFILE] => and press [ENT] key after selection.

This setup is to designate OUTLINE and antenna location of CCRP.

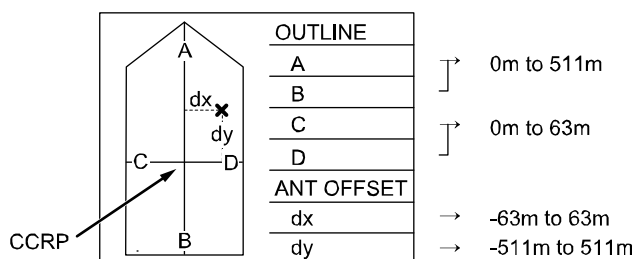

When show the own ship profile, turn ON own ship profile.

☞ Refer to "**SHIP OUTLINE**" (page4-14).

Ship's width (C+D) is 10m or less, even 0.125NM does not show the own ship profile.

### About [Reference point]

The base point for range, bearing, relative course, relative speed, CPA or TCPA, EBL or VRM is named [Reference point], respectively.

Either CCRP or ANT position can be used as the reference point.

Selection of the reference point is made in [REF] located of the upper left side.

\*The center of echo image (PPI) is ANT.

When CCRP is selected for the reference point, there is possibility that CCRP locates outside of 90 % echo image area in short distance range.

In this case, the reference point is automatically changed to ANT position.

\*TRAIL is erased and new trail is displayed upon change of the reference point.

## 1.9 Inside save of setup data at the time of setting up (Cannot use while transmitting)

With saving setup data at the time of setting up inside radar, the initial setup status at the time of setting up can be restored again, whenever optimal image display can not be obtained due to wrong operation at the time of changing setup value.

All values that have been changed after delivery from the plant such as menu setup, screen setup and MAP input data, etc. will be stored.

When saving setup data at the time of setting up,

- 1 Press [MENU] key to display "Menu".  
Select [MAINTENANCE] => [BACKUP] => [SYSTEM SAVE] => [GO] and then press [ENT] key.

When restoring setup data at the time of setting up,





- 1 Press [MENU] key to display "Menu".  
Select [MAINTENANCE] => [BACKUP] => [SYSTEM LOAD] => [GO] and then press [ENT] key.





\* Inside save of setup data should be surely saved after initial setup.



When some malfunction of display unit is found, such as frozen screen, initialization may be required. By performing inside save of setup data, the setup data at the time of setting up can be restored after initialization.

 Refer to "Screen is frozen" (page7-8).

### List of retained parameters

MENU  Refer to "General operation (Menu)" (page4-1).			
RADAR  Refer to Page 4-1.	TUNE MAN ADJ		TGT AUTO ACQ
	TRAIL TRUE / REL		TGT GZ
	TRAIL TIME		AIS SLEEPING LOST
	TRAIL SHAPE		AIS NO HDG / COG
	TRAIL DETECT LEVEL		NAVLINER CROSS
	TRAIL RESET		PRIORITY
	OFF CENT POINT	OS/TGT	VECT TRUE / REL
	AUTO OFF CENT		VECT TIME
ALARM  Refer to Page 4-6.	ECHO ALARM	Refer to Page 4-10.	VECT TIME INCREMENT
	ECHO ALARM MODE		TGT ID DISP
	ECHO ALARM DETECT LEVEL		ID DISP SIZE
	MAP AREA		INPUT RNG
	MAP AREA DETECT LEVEL		ASSOCIATION
	TGT CPA / TCPA		ASSOCIATION RNG

MENU					
OS/TGT  Refer to Page 4-10.	ASSOCIATION CRS		EBL2 OFFSET		
	ASSOCIATION SPD	MAP  Refer to Page 4-25.	DISP		
	ASSOCIATION SPD LIM		GROUP		
	ASSOCIATION TIME REPRIEVE		DISP COAST LINE		
	AUTO ACQ AREA		DISP NAV LINE		
	OS STAB INDICATOR		DISP ROUTE		
	OS ANT POSN		DISP EVENT MARK		
	OS PAST TRK TIME		DISP AREA		
	OS PAST TRK TIME INCREMENT		EDIT COAST LINE		
	OS STERN LINE		EDIT NAV LINE		
	OS SHIP OUTLINE		EDIT ROUTE		
	AIS		EDIT EVENT MARK		
	AIS SELECT ID		EDIT AREA		
	AIS LABEL		MONITORED ROUTE		
	AIS SHIP OUTLINE		WPT ID DISP		
	AIS HDG LINE		DATUM		
	AIS TURN INDICATOR		POSITION OFFSET		
	AIS CLASS B		MAN OFFSET		
	TOOL  Refer to Page 4-20.		AIS ATON	BRILL  Refer to Page 4-34.	COLOR
			AIS SAR		ECHO
AIS BASE		TRAIL			
AIS OS DISP		BKGND PPI			
AIS MESSAGE DISP		BKGND DATA			
TT (ARPA)		DATA			
TT (ARPA) SELECT ID		BRIGHTNESS ECHO			
TT (ARPA) EDIT NAME		BRIGHTNESS TRAIL			
TEST TGT		BRIGHTNESS BKGND			
RR		BRIGHTNESS OS/TOOL			
BRG TRUE / REL		BRIGHTNESS TGT			
CURSOR SHAPE		BRIGHTNESS MAP/ROUTE			
PI LINE		BRIGHTNESS CURSOR			
PI LINE DISP	BRIGHTNESS DATA				
PI LINE START RND	BRIGHTNESS WARNING				
PI LINE END RNG	BRIGHTNESS ALARM				
PI DISP SIDE	SYSTEM	INTER SWITCH MODE			
EBL1 OFFSET		INTER SWITCH ANT POSN			

MENU			
SYSTEM  Refer to Page 4-37.	TIME		POSITION DATUM
	ASSISTANT DISP		SET / DRIFT
	TGT LIST SORT		SET / DRIFT MAN
	USER		TIME
	SOUND		TIME CLOCK TIME ZONE
	SOUND FREQUENCY		TIME CLOCK SET
	SOUND KEY CLICK		DETAIL OUTPUT NAV
	BITE SERIAL SEL		DETAIL OUTPUT EPFS
	MON		DETAIL ALROUT SEL
	LANG		DETAIL INPUT
MAINTENANCE  Refer to Page 4-43.	TUNE		DETAIL FORMAT
	TUNE AUTO ADJ		OS PROFILE
	TUNE MAN ADJ		SECTOR MUTE
	HL OFFSET		SECTOR MUTE START
	TX DELAY		SECTOR MUTE END
	ANT HEIGHT		PRESET GAIN MAN
	ANT CABLE		PRESET GAIN OFFSET BW
	MBS		PRESET SEA AUTO LAND
	FUNCTION KEY F1		PRESET SEA AUTO SEA
	FUNCTION KEY F2		PRESET SEA MAN MAX
	FUNCTION KEY F3		PRESET SEA MAN MIN
	FUNCTION KEY F4		PRESET SEA MAX OFFSET
	FUNCTION KEY F5		PRESET RAIN MODE
	FUNCTION KEY F6		PRESET RAIN MAX
	HDG OFFSET		PRESET RAIN MIN
	STW		PRESET CFAR MAX
	STW MAN		PRESET CFAR MIN
	COG / SOG		PRESET MBS
	POSITION		PRESET TT (ARPA) TGT LEVEL
	POSITION MAN		PRESET VIDEO SETUP
POSITION OFFSET		PRESET VIDEO SETUP HIGH	
POSITION OFFSET MAN		PRESET VIDEO SETUP LOW	

DISPLAY  Refer to “Name of radar display” (page2-2).			
RANGE	Refer to page2-6	EBL1	Refer to page2-15
MODE	Refer to page2-23	EBL2	Refer to page2-15
STAB	Refer to page3-2	PI	Refer to page2-17
Antenna position	Refer to page4-11	PI TRUE / REL	Refer to page2-17
OFF CENT	Refer to page2-22	ERBL	Refer to page2-20
STANDBY / TX	Refer to page2-5	ERBL TRUE / REL	Refer to page2-20
Pulse length	Refer to page2-13	CURSOR TRUE / REL	
REFERENCE	Refer to page1-5	VRM1	Refer to page2-14
INTER SWITCH	Refer to page4-37	VRM2	Refer to page2-14
TUNE	Refer to page1-1	TIME	Refer to page4-45
BRILL	Refer to page2-5	VECT	Refer to page3-15
PANEL	Refer to page2-1	VECT TRUE / REL	Refer to page3-15
PROCESS	Refer to page3-4	LIMIT CPA	Refer to page3-15
ENH	Refer to page3-6	LIMIT TCPA	Refer to page3-15
IR	Refer to page3-7	LOST ALARM	
VIDEO	Refer to page3-8	ASSOCIATION	Refer to page3-18
DAY/NIGHT	Refer to page2-21	AIS	Refer to page3-38
SECTOR MUTE	Refer to page4-48	TT (ARPA)	Refer to page3-24
MAP DISP	Refer to page4-25	PAST POSN	Refer to page3-17
TRAIL TIME	Refer to page3-9	FILTER CPA/TCPA	Refer to page3-39
TRAIL TRUE / REL	Refer to page3-9	FILTER RNG	Refer to page3-39
OS PAST TRK TIME	Refer to page4-12	FILTER CLASS	Refer to page3-39
OS PAST TRK TRUE / REL	Refer to page4-12	AIS AUTO ACQ CPA/TCPA	Refer to page3-39
EBL TRUE / REL	Refer to page2-15	AIS AUTO ACQ RNG	Refer to page3-39
EBL OFFSET	Refer to page4-21	ASSISTANT DISP	Refer to page4-39

## 1.10 External save of setup (Cannot use on transmitting)

To prepare for the case when the radar becomes inoperative, setup value can be stored externally and can read out.

All values that have been changed after delivery from the plant such as menu setup, screen setup and MAP input data, etc. will be stored.

This is also effective when replacing the radar.

The external saving shall be stored by a PC (Personal Computer) with serial communication facility [with serial ports provided or USB (Universal Serial Bus) - serial conversion cable attached].

Dedicated software is required for PC.

Dedicated cable is required to connect the radar with PC.

Please contact with the sales agent or directly with our sales department for PC software and the dedicated cable.

Carry on the following procedure after confirming the setup values is saved in the external PC and can be read out.

When saving setup values externally,

- 1 Press [MENU] key to display "Menu".  
Select [MAINTENANCE] => [BACKUP] => [EXT SAVE] => [GO] and then press [ENT] key.

When reading out setup values from external PC,

- 1 Press [MENU] key to display "Menu".  
Select [MAINTENANCE] => [BACKUP] => [EXT LOAD] => [GO] and then press [ENT] key.

## Chapter 2 Basic operation [for operating unit (panel)]

### 2.1 Illustration of operating unit (panel)

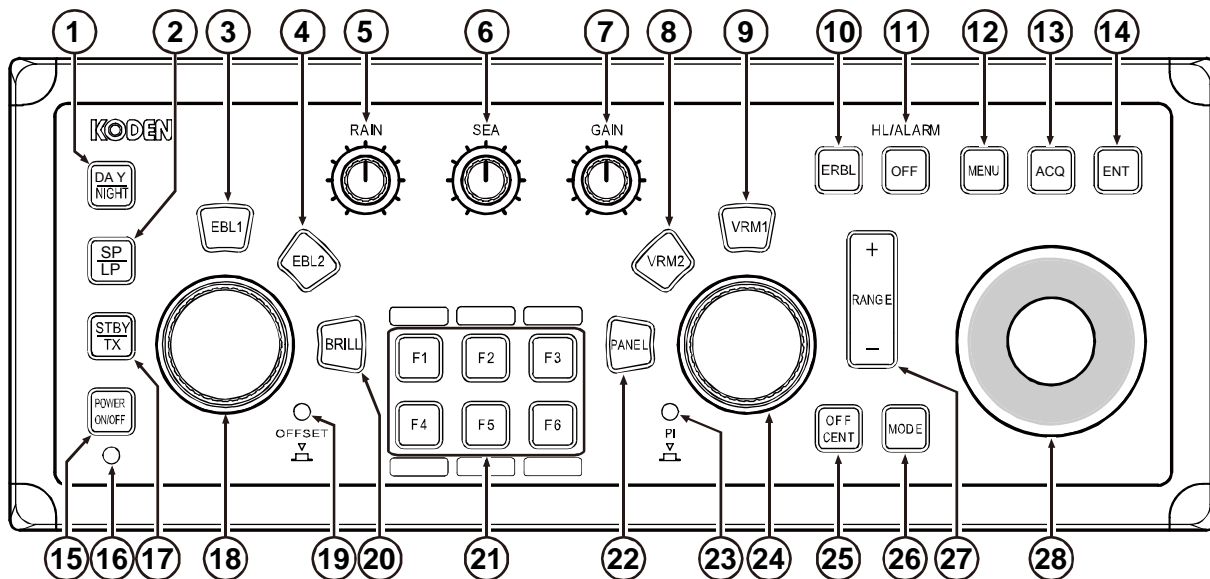

No.		Page
1	[DAY / NIGHT] key	2-21
2	[Pulse length Short/Long] key	2-13
3	[EBL1] key	2-15
4	[EBL2] key	
5	[Anti-rain clutter] knob	2-10
6	[Anti-sea clutter] knob	2-8
7	[Gain] knob	2-7
8	[VRM2] key	2-14
9	[VRM1] key	
10	[ERBL] key	2-20
11	Heading line/ Alarm sound [Off] key	2-21
12	[Menu] key	3-1
13	[Acquisition] key	3-24
14	[Enter] key	---

No.		Page
15	[Power On/Off] key	2-4
16	Power lamp	
17	[Stand by/TX] key	2-5
18	[EBL] knob	2-15
19	[Offset] lamp	2-16
20	[Display brilliance] key	2-5
21	Function keys	2-27
22	[Panel illumination] key	2-5
23	[Parallel index lines] lamp	2-17
24	[VRM] knob	2-14
25	[Off center] key	2-22
26	[Display mode] key	2-23
27	[Range] key	2-6
28	Track ball	---



## 2.2 Name of radar display

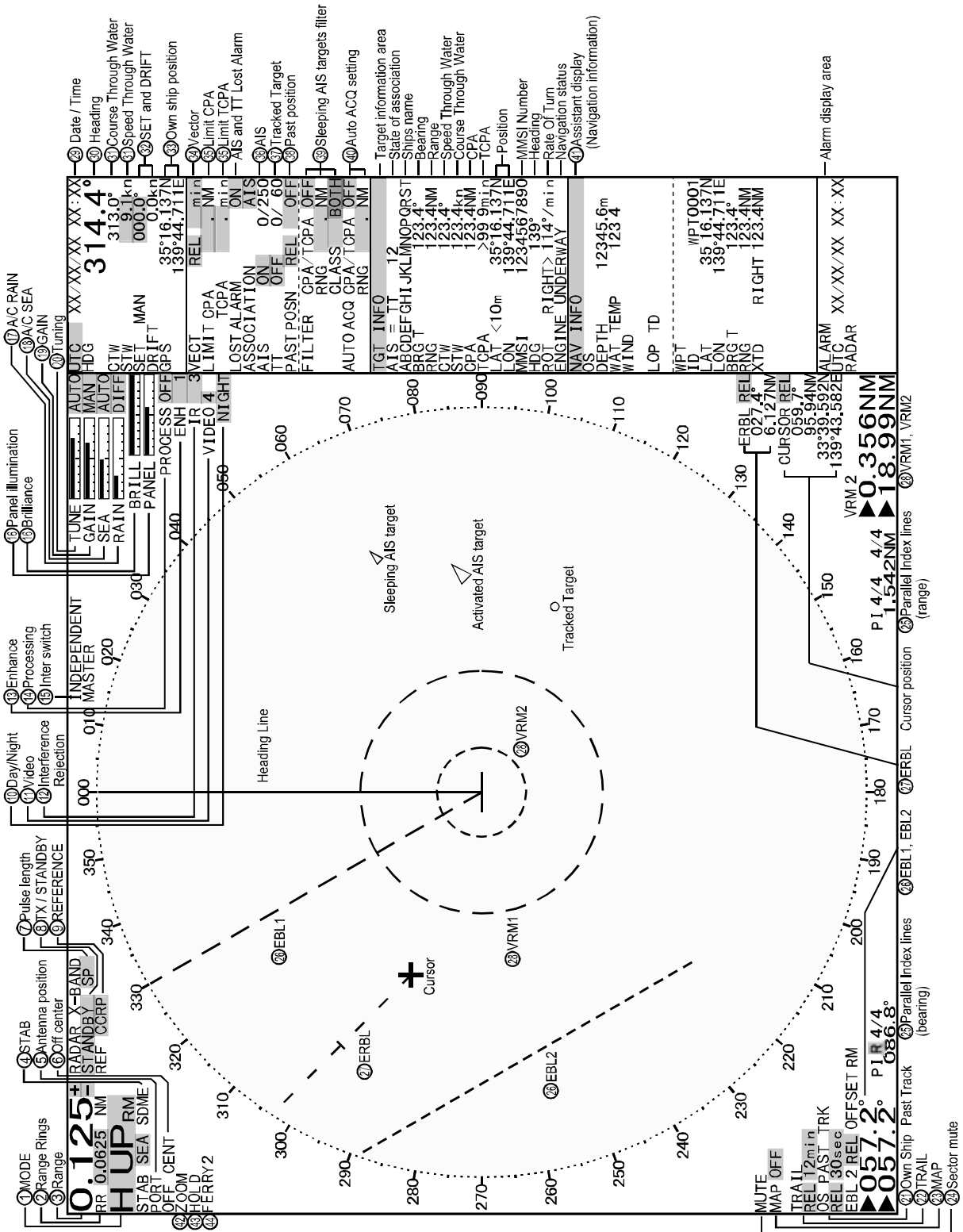

No.		Page
1	Display mode	2-23
2	Range rings	3-11
3	Range	2-6
4	STAB	3-2
5	Antenna position	4-38
6	Off center	2-22
7	Pulse length	2-13
8	STAND BY / TX	2-5
9	Reference	1-5
10	Day / Night	2-21
11	Video	3-8
12	IR	3-7
13	Enhance	3-6
14	Processing	3-4
15	Inter switch	4-37
16	Brilliance and illumination	2-5
17	RAIN	2-10
18	SEA	2-8
19	GAIN	2-7
20	Tuning	1-1
21	Own ship past track	4-12
22	TRAIL	3-9

No.		Page
23	MAP	4-25
24	Sector mute	4-48
25	PI (Parallel index line)	2-17
26	EBL	2-15
27	ERBL	2-20
28	VRM	2-14
29	Date / Time	4-38
30	Heading	4-44
31	CTW / STW	4-44
32	SET and DRIFT	4-45
33	Own ship position	4-45
34	Vector	3-15
35	CPA / TCPA	3-15
36	AIS	3-38
37	TT (ARPA)	3-24
38	Past position	3-17
39	Filter	3-39
40	Auto ACQ	3-39
41	Assistant display	4-39
42	Zoom	4-2
43	Hold	4-2
44	Ferry	4-4

## 2.3 Power On/Off

### Power On

---

Hold [POWER ON/FF] key until buzzer sound occurs. Radar system is activated with [Peep] sound.

- After the power on, wait for 120 sec. (\*1) or 180 sec. (\*2) until [WAIT] countdown sign at the center of the display has disappeared.
- The brilliance of the display is set to the previous value of the last power off.
- During operation, [POWER LAMP] under [POWER ON/OFF] key lights up red.
  - (\*1) MDC-2960/2910/2960BB/2910BB
  - (\*2) MDC-2920/2920BB

\*The power source shall not be turned off until operational screen is displayed.

### Power Off

---

Hold [POWER ON/FF] key for five sec. for power off.

\*The power source shall be turned off by pressing [POWER ON/FF] key without fail.

When the power source is stopped in power-on state, an important setup data may be lost.

The re-entry of power shall be performed after five seconds or more have passed after power source shutdown.

## 2.4 Change brilliance of display unit

### Change display brilliance

- 1 Press [BRILL] key.
- 2 A triangle mark will appear at the left of BRILL adjustment window in the upper right of the screen.  
▶ BRILL 
- 3 Turn [EBL] knob to clockwise to increase display brilliance.  
Turn [EBL] knob to counterclockwise to decrease the display brilliance.  
The display brilliance changes at five steps by pushing [EBL] knob.

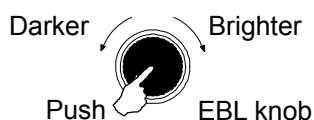

### Change lighting of operating panel illumination

- 1 Press [PANEL] key
- 2 A triangle mark will appear at the left of PANEL illumination adjustment window in the upper right of the screen.  
▶ PANEL 
- 3 Turn [VRM] knob to clockwise to increase the lighting of the panel illumination.  
Turn [VRM] knob to counterclockwise to decrease the lighting of the panel illumination.  
The panel illumination changes at five steps by pushing [VRM] knob.



## 2.5 Transmission

A Menu will once disappear if transmission is turned on or off. For menu operation, display a menu again.

### Start transmission

Press [STBY/TX] key in [STAND-BY] status to start transmission.

After the power on, [STAND-BY] status is displayed after 120 sec. (\*1) or 180 sec. (\*2)

(\*1) MDC-2960/2910/2960BB/2910BB

(\*2) MDC-2920/2920BB

### Stop transmission

Press [STBY/TX] key in [Transmission] status to stop transmission.

The status returns to [STAND-BY] after the end of transmission.

## 2.6 Change range (indicated distance)

The amount of coverage area can be changed with selecting range.

Larger the value of range the more the coverage area expands. (But a target will become smaller.)

The range value is indicated at the upper left on the display.

[RANGE] can be changed directly at the upper left of the screen, with trackball and [ENT] key, without using [RANGE] key.

Range is changed centering on the antenna location.

- 1 Press [Range +] key to zoom out the picture, and to observe a wider area.  
Press [Range -] key to zoom in the picture, to magnify and to observe nearby Antenna position.

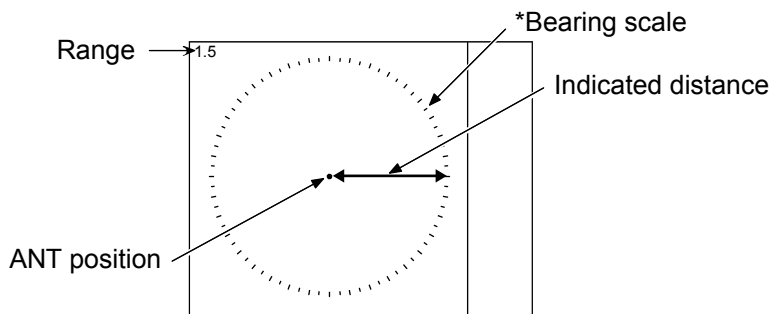

Model-specific ranges are as shown below.

Model name	MDC-2920/MDC-2920BB (Max. output : 25 KW)												
	MDC-2910/MDC-2910BB (Max. output : 12 KW)												
	MDC-2960/MDC-2960BB (Max. output : 6 KW)												
Range(NM)	0.125	0.25	0.5	0.75	1.5	3	6	12	24	48	72	96	

### \*About bearing scale

Bearing scale is useful to identify heading of own ship and target bearing.

If bearing mode is [TRUE], north is expressed as 0°.

If bearing mode is [REL], heading of own ship is expressed as 0°.

☞ Refer to "**Bearing mode set up**" (page3-12)

Central point of bearing scale is reference point.

☞ Refer to "**Setup own ship profile**" (page1-5) to setup reference point.

## 2.7 Adjust receiver gain (GAIN)

It is recommended to adjust [GAIN] in the top right side of the screen to have the evenly scattered vague background noise with low intensity in the PPI.

Lower [GAIN] than required may result in overlooking small vessels and buoys.

Higher [GAIN] than required may result in difficult discrimination between small ships and densely displayed high level background noise.

Under some situation, desired target object may be masked by side lobe of antenna directivity or false echo by multi pass.

☞ Refer to “**Principle of radar system**” (page6-1)

Lower [GAIN] until masked target echo can be recognized outside of the area where 2.8 “Reject sea clutter (anti-SEA)” is effective.

However since lower [GAIN] tends to lose weak target echo, try to return the [GAIN] to original position each time [GAIN] is changed to maintain target recognition. In the short distance area where anti-SEA is effective, recognize target by adjusting MAN SEA.

When suppressing RAIN clutter (rain & snow), adjust GAIN-knob and RAIN-knob side by side.

☞ Refer to “**Reject sea clutter (anti-SEA)**” (page2-8)

☞ Refer to “**Reject rain/snow clutter (anti-RAIN)**” (page2-10)

[GAIN] state is displaying in the upper left of the screen.

- 1 Turn [GAIN] knob to clockwise to increase receiving gain.  
Turn [GAIN] knob to counterclockwise to decrease the receiving gain.



Note:

- Decrease gain for shorter range and dense targets.
- Increase gain for long range targets and small target however take care in not using too much gain and losing targets in the surrounding noise.
- Adjustment is not available while RAIN MODE is set to CFAR (Constant False Alarm Rate).

☞ Refer to “**RAIN MODE**” (page4-51)

Result picture after adjustment a [GAIN] knob

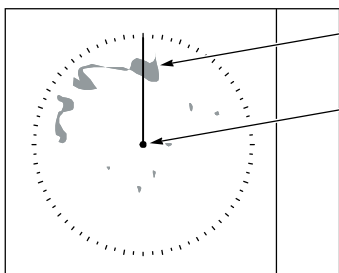

< Picture of too low gain >

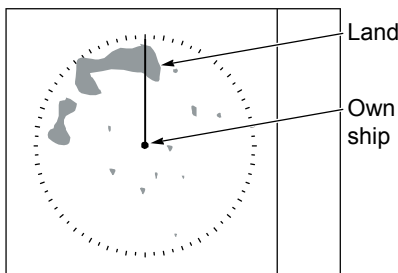

< Picture of moderate gain >

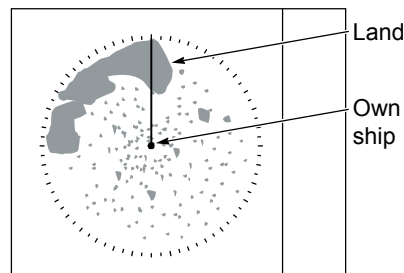

< Picture of too high gain >

## 2.8 Reject sea clutter (anti-SEA)

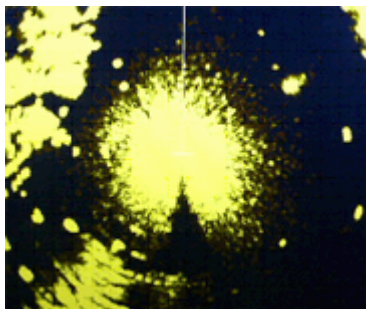

SEA clutter at center

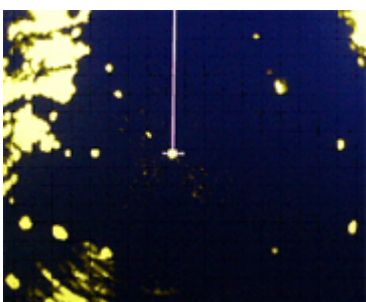

after Adjusted MAN SEA

MAN (manual) SEA and AUTO (automatic) SEA are provided for anti-SEA function. On the rough sea, SEA clutter noise appears around antenna position (center spot), and short distant targets are masked and not recognizable. In that case, anti-SEA function suppresses SEA clutter noise and reveals masked target echoes. Recommended adjustment of anti-SEA is to adjust to make echoes from SEA clutter vaguely displayed by dark level.

If [SEA] level is too high to show sea clutter noise, short distance gain is over suppressed and it may result in loss of targets like buoys and small ships.

On the other hand, if [SEA] level at top left side of the screen is too low, clutter noise around antenna position (center spot) is displayed by high intensity level and it makes difficult to discriminate small ships and buoys from sea clutter.

Anti-SEA is effective to suppress false echoes and ground clutter in short distance. However adjustment of GAIN should be used beyond effective coverage of anti-SEA.

If target echoes are masked by excessive false echoes within anti-SEA effective, then adjust MAN SEA to confirm it. Excessive anti-SEA may lose echoes from small ships and buoys. So, return to appropriate anti-SEA level for normal use.

- Small target becomes harder to detect when SEA is used together with RAIN.
- Adjustment is not available while RAIN is set to CFAR (Constant False Alarm Rate).

☞ Refer to “Reject rain/snow clutter (anti-RAIN)” (page2-10)

### Selection of MAN SEA and AUTO SEA

By control-knob

When the [SEA]-knob is pressed, [AUTO SEA] and [MAN SEA] change alternately.

By trackball

- 1 Roll the trackball to place the + CURSOR on the [MAN] or [AUTO] (whichever is shown) at right side of [SEA] on the top of the display.
- 2 Push the [ENT] key to display [AUTO] or [MAN] as appropriate.

### **AUTO adjustment of the SEA**

---

When [AUTO SEA] is set, anti-SEA is adjusted automatically.

Note:

AUTO SEA may erase weak target echoes. If excessive SEA clutter is erased excessively or too much clutter is observed, fine-adjust by [SEA] knob in the cases of software versions of KM-E68V2.01C and after. In the cases of versions earlier than KM-E68V2.01C, adjust it by referring to Installation Manual Adjust the AUTO SEA. In case there are strong echo targets within 500m radius from the radar antenna such as in the harbor or canal, anti-SEA tends to suppress excessively. Use MAN SEA in that case.

### **Manual adjustment of the SEA**

---

When [MAN SEA] is selected, anti-SEA can be adjusted manually.

By using [SEA] knob, suppress this effect and make targets easier seen.

[SEA] state is displayed in the upper left of the screen.

- 1** Turn [SEA] knob to clockwise to increase anti-sea clutter effect.  
Turn [SEA] knob to counterclockwise to decrease anti-sea clutter effect.
- 2** Turn [SEA] knob clockwise until even dark SEA clutter is displayed by observing the screen.
- 3** Adjust [SEA] knob from time to time to get dark SEA clutter on the screen as intensity of SEA clutter changes as time passes.



Note:

- When waves do not affect the result, turn the knob fully counterclockwise.
- This function reduces gain in closest ranges. Too much sea clutter may result actual targets being lost.
- Manual [SEA] shall be kept watched for sea clutter and adjusted to the optimal value adapting to changes.
- If [SEA] and [anti-RAIN] are used in combination, then small targets will be less visible.



## 2.9 Reject rain/snow clutter (anti-RAIN)

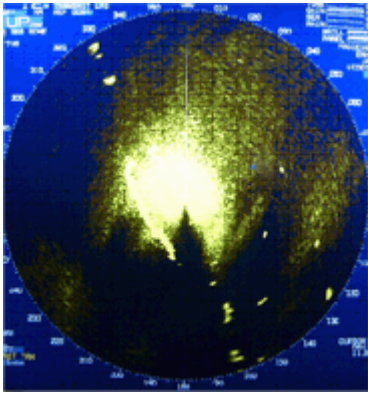

Rain clutter

In rain or snow, targets become hard to be seen as a result of unwanted weather reflection.

Rain or snow image appears as a large target echo with surrounding mid gradation rim as shown by the picture.

Anti-RAIN has DIFF and CFAR.

Adjustment of DIFF (Differentiation) and CFAR (Constant False Alarm Rate) by turning [RAIN] knob suppresses clutter, and makes the picture easier to observe.

DIFF is effective for suppression of rain and snow.

CFAR is effective for suppression of sea clutter.

☞ Refer to "RAIN MODE" (page4-51)

[RAIN MODE] can be changed directly in the upper light of the screen without using menu function.

- Small target becomes harder to detect when RAIN is used together with SEA.
- The performance of radar detection range is degraded by rain as shown in the figure below.

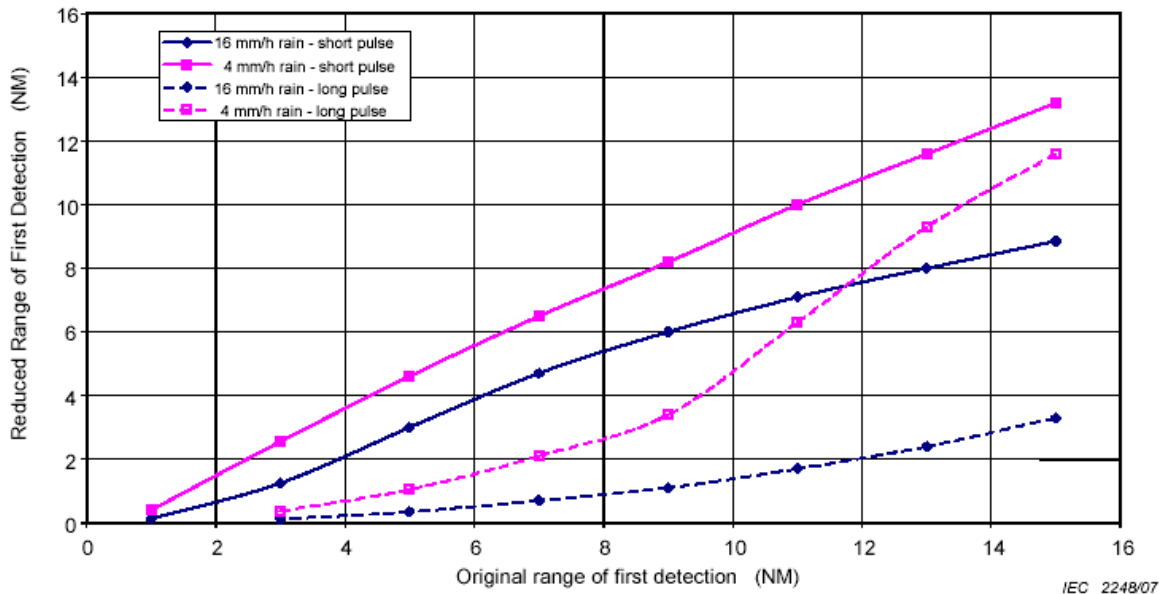

### Changing method of CFAR and DIFF

By [RAIN] knob

When the [RAIN] knob is pressed, [DIFF] and [CFAR] change because of the alternation.

By trackball

- 1 Roll the trackball to place the + CURSOR on the [DIFF] or [CFAR] (whichever is shown) at right side of [RAIN] on the top of the display.
- 2 Push the [ENT] key to alternate [CFAR] and [DIFF].

### CFAR (Constant False Alarm Rate) adjustment

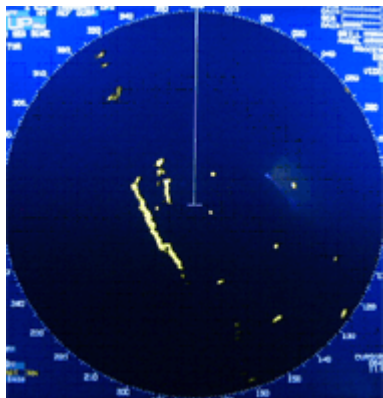

After adjust CFAR

CFAR function is applicable when [CFAR] is indicated at the upper right side of the screen.

CFAR has superiority over DIFF (Differentiation) as small target echoes cannot be slimed.

Level of [RAIN CFAR] is indicated in the left side of [CFAR] indication.

- 1 Turn [RAIN] knob to clockwise to increase anti-clutter effect.  
Turn [RAIN] knob to counterclockwise to decrease anti-clutter effect.



- 2 Turn [RAIN] knob clockwise to get eve dark clutter while watching the screen.

#### Note:

- The knob should be turned to leftmost position in normal environment.
- Turning the knob to the right shows the targets hidden in the rain/snow image, but care shall be taken that small target may be hidden and not displayed.
- If there are strong echo targets within 500m radius from the radar antenna such as in the harbor or canal, CFAR tends to suppress targets excessively. In that case change CFAR to DIFF and use MAN SEA in addition.
- If CFAR is selected, then [GAIN] and [SEA] knobs become invalid.

## RAIN DIFF (Differentiation) adjustment

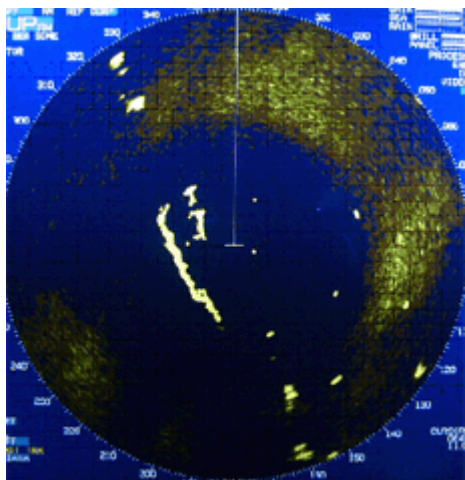

after adjusted anti-SEA

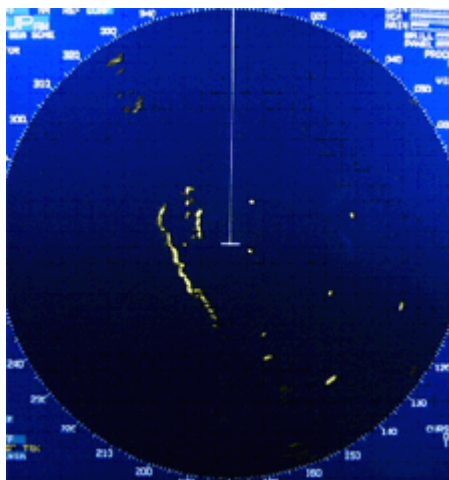

after adjusted anti-SEA &amp; RAIN DIFF

- 1 Turn [RAIN] knob to clockwise to increase anti-clutter effect.  
Turn [RAIN] knob to counterclockwise to decrease anti-clutter effect.



- 2 Use anti-SEA (AUTO SEA or MAN SEA).  
☞ Refer to “**Reject sea clutter (anti-SEA)**” (page2-8)
- 3 While observing the screen, suppress RAIN clutter outside of anti-SEA effective area by turning [RAIN] knob clockwise. Adjust RAIN so that it may remain as small spots.
- 4 While observing the screen, turn [GAIN] knob counterclockwise to make the small spots to dark spots.
- 5 Intensity of RAIN clutter is affected by weather. Adjust by [RAIN] knob according to weather change by watching the screen.

### Note:

- The knob should be turned to leftmost position in normal environment.
- Turning the knob to the right shows profiles of the targets hidden in the rain/snow image, but care shall be taken that small target may be hidden and not displayed.
- Small target becomes harder to detect when RAIN is used together with SEA.

## 2.10 Change transmission pulse length (SP/LP)

This radar provides a function capable of achieving suitable target detection by manually changing the transmission pulse length.

Seven types of pulse length are adopted for this radar, SP => MP1 => MP2 => MP3 => MP4 => LP1 => LP2.

	Pulse length	Pulse repetition frequency	IF Band width
SP	80ns	2000Hz	15MHz
MP1	200ns	2000Hz	15MHz
MP2	300ns	2000Hz	15MHz
MP3	300ns	2000Hz	5MHz
MP4	600ns	1000Hz	5MHz
LP1	1200ns	500Hz	5MHz
LP2	1200ns	450Hz	5MHz

The short (narrow) pulse length used in short range has high resolution and is effective for dense targets.

The long (wide) pulse length used in long range has high gain (sensitivity) and is effective for detecting small targets.

Two types of pulse length are selectable for 1.5NM, 3NM and 6NM.

Range(NM)	0.125	0.25	0.5	0.75	1.5	3	6	12	24	48	72*	96**
SP mode	SP	SP	SP	SP	MP1	MP2	MP4	LP1	LP1	LP1	LP1	LP2
LP mode	SP	SP	SP	SP	MP3	MP4	LP1	LP1	LP1	LP1	LP1	LP2

\* 72NM is for 12kW only.

\*\* 96NM is for 25kW only.

- 1 Press [SP/LP] key. Two types of pulse length mode are toggled by each key press.  
Current pulse length is shown at the upper left of the display.

\* [SP/LP] can be changed directly at the upper left of the screen, with trackball and [ENT] key, without using menu function.

## 2.11 Measure distance and bearing of a target

### Measure distance (VRM: Variable Range Maker)

The VRM is used to measure the distance of a target from the reference point.

 Refer to “**Setup own ship profile**” (page1-5) to setup reference point.

Two VRM's (“VRM1” and “VRM2”) are provided.

Adjust these [VRM] knobs and lay each circle on the desired target to read the distance to the target on the display.

- 1 Press [VRM1] key to display a broken line circle of VRM1.

The distance to the target is indicated on the lower right on the display, and also a ► symbol is displayed on the left side of the distance value.

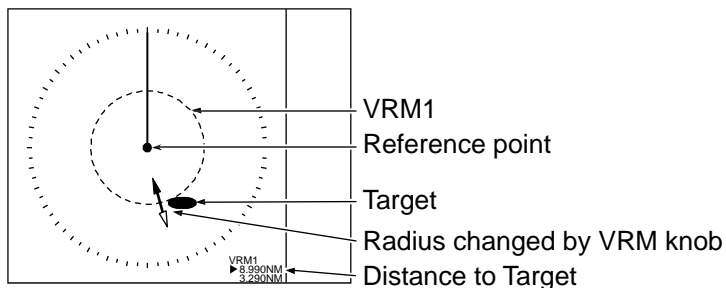

- 2 The broken line circle is zoomed in or zoomed out by turning [VRM] knob clockwise or counterclockwise, respectively.

\*Turning [VRM] knob (while pressing it) changes the range quickly.

At the same time, the range changes and the distance to the target can be read out on the display.

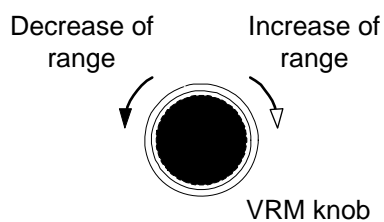

- 3 Another press of the [VRM1] key, and the broken circle disappears.  
At the same time, the distance value at the lower right of the display disappears.
- 4 Press [VRM2] key to activate the dotted line circle of VRM2.  
Operation procedure and distance display are the same as [VRM1].
- 5 If you want to display both VRM1 and VRM2 simultaneously, press [VRM1] key and [VRM2] key.  
Then, both broken line circle and dotted line circle are displayed.
- 6 Switching between VRM1 and VRM2 is performed with pressing either of [VRM] keys as desired.  
When the selected key is pressed, the color of operation panel changes to red.

## Measure bearing (EBL: Electronic Bearing Line)

This feature is used for measuring the bearing of the target from the base point (reference point for default value.) Two types of [EBL1] and [EBL2] is provided.

☞ Refer to “**Setup own ship profile**” (page1-5) to set up reference point.

Rotate [EBL] knob and lay each bearing line on the desired target and read the bearing on the display.

☞ Refer to “**Bearing mode set up**” (page3-12) to set up the bearing mode.

[Bearing mode] can be changed directly in the lower left of the screen, with trackball and [ENT] key, without using menu function.

- 1 Press [EBL1] key, and the bearing line of EBL1 is displayed as a broken line.

The bearing value to the target is indicated at the lower left of the display, and a ► sign is shown at the right side of the value.

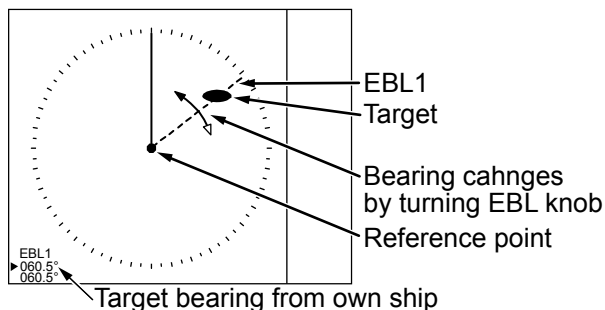

- 2 Rotate bearing line using the [EBL] knob to adjust the line on the desired target.

The bearing value changes at the same time and you can read the bearing of the target.

\*Turning [EBL] knob (while pressing it) changes the bearing quickly.

Counter clockwise      Clockwise

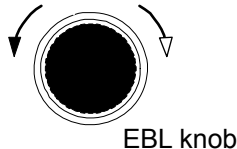

- 3 Another press of the [EBL1] key, and the broken line disappears and the bearing value on the lower left of the display disappears.

- 4 Press [EBL2] key, and the bearing line is shown as a dotted line.

The operation procedure and display of the bearing is the same as [EBL1].

- 5 If you want to display both EBL1 and EBL2 simultaneously, press [EBL1] key and press [EBL2] key.

Then, you can show both the broken bearing line and the dotted bearing line.

- 6 Press [EBL] key to switch EBL1 or EBL2 as you want.

The color of selected [EBL] key on the operating panel changes to red.

### Using the EBL based on a position other than reference point (EBL OFFSET)

EBL base point can be changed to the position that is other than the initial reference point.

By changing the base point, the bearing from a random target can be known.

- 1 Display the EBL for which the base point is required to be changed.
- 2 Using the trackball, put the cursor on the position to be changed.

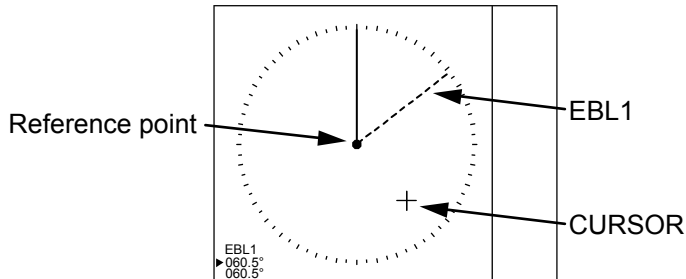

- 3 Press [EBL] knob, and the base point of EBL changes.  
During offset, the color of [Offset lamp] at the lower right of the [EBL] knob changes and the color of numerical figures indicated is reversed.

EBL knob

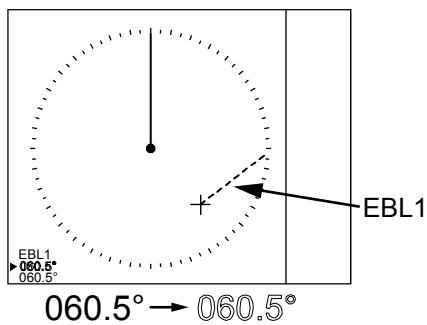
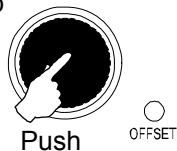

- 4 Press the [EBL] knob again, and the base point returns to the reference point.

The base point for VRM cannot be changed.

## Measure distance/bearing (PI: Parallel index line)

This function is used to display a parallel straight line from the reference point.

☞ Refer to “**Setup own ship profile**” (page1-5) to set up reference point.

Display location (distance, bearing) of each line can be changed independently. The length of LINE can be also designated.

☞ Refer to “**Bearing mode set up**” (page3-12) to set up the bearing mode.

[Bearing mode] can be changed directly in the lower left of the screen, with trackball and [ENT] key, without using menu function.

All lines displayed can be simultaneously changed. When lines of fixed length are required to be used, please change the mode to “PI MODE”.

☞ Refer to “**PI MODE**” (page4-22).

**1** Push [VRM] knob, and PI is displayed.

When pressing [VRM] knob again, line number will be changed and will be turned off after the last number of line.

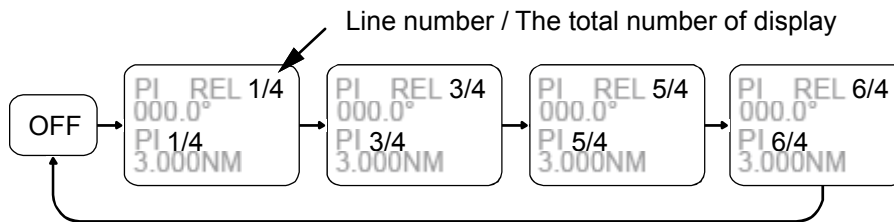

**2** While activated, the bearing and range are shown at the lower left and lower right of the center of the display, respectively.

The lamp color of PI located at the lower left of [VRM] knob changes.

VRM knob

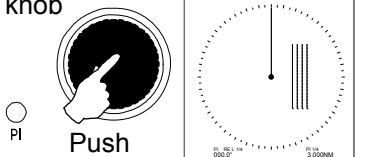

**3** The range of selected line can be changed by turning [VRM] knob.

\* Turning [VRM] knob (while pressing it) changes the range quickly.

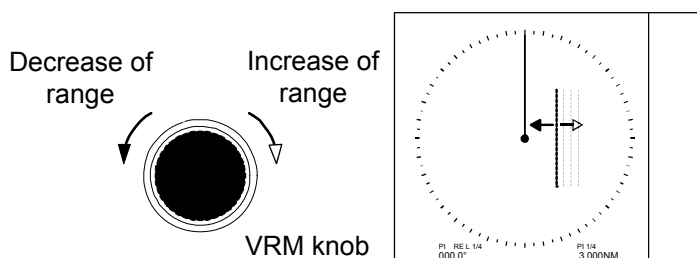



- 4 Turning [EBL] knob changes the bearing of a selected line.  
 \* Turning [EBL] knob (while pressing it) changes the bearing quickly.

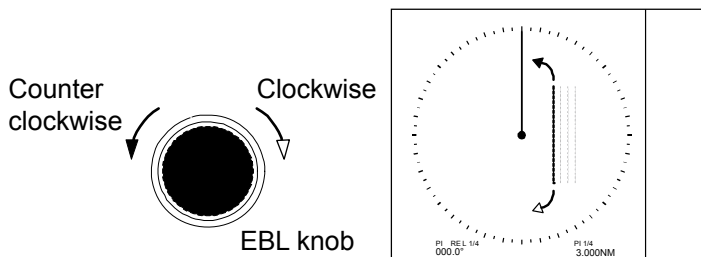

- 5 Turning [VRM] knob (while pressing [OFF] key) changes the range of all the displayed lines.  
 Turning [EBL] knob (while pressing [OFF] key) changes the bearing of all the displayed lines.  
 \* Turning a knob (while pressing it) results in a quick change.

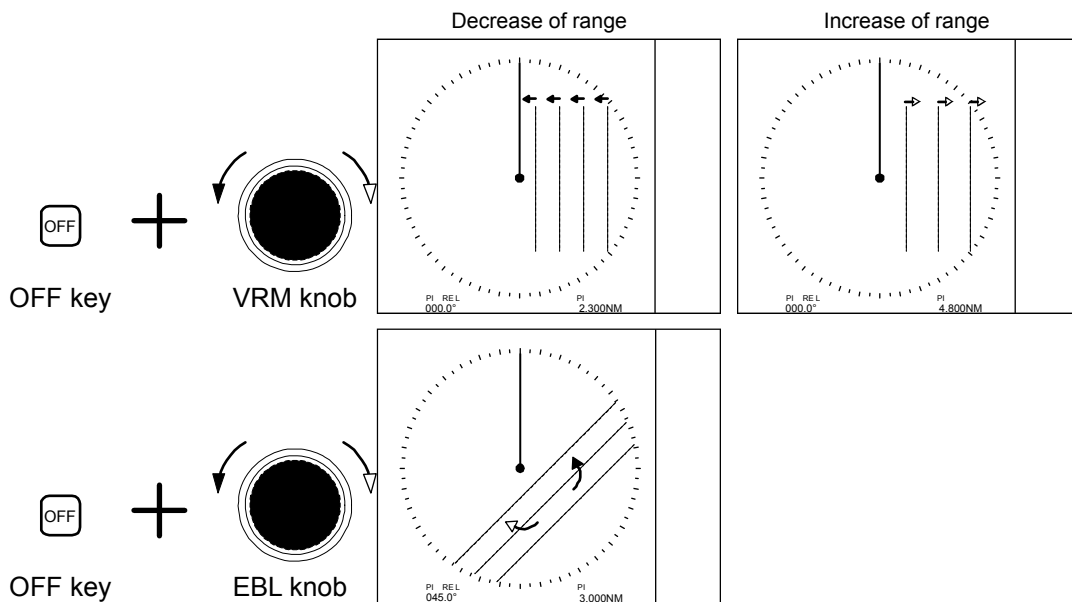

- 6 Pressing [VRM] knob (while pressing [OFF] key) returns all the lines to initial position.
- 7 You can designate [ON/OFF] of the selected line and designate length of each line to be used.  
 Press [MENU] key to display "Menu".  
 Select [TOOL] => [PI] and press [ENT] key after the selection.  
 LINE: It designates line number (1 to 7) to be set up.  
 DISP: It designates [ON/OFF] of the line designated by [LINE].  
 START RNG: It designate the starting range of line designated by [LINE].  
 END RNG: It designates ending range of the line designated by [LINE].

8 PI DISP SIDE: It designates the display direction.

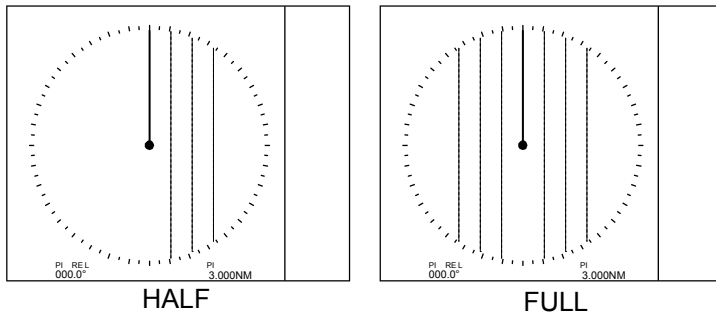

**Measure distance/bearing (ERBL: Electronic range and bearing line)**

The given point of distance and bearing can be measured with the cursor as follows.

Measurement of distance and bearing from reference point can be performed by adjusting cursor to reference point position.

☞ Refer to “**Setup own ship profile**” (page1-5) to setup reference point.

☞ Refer to “**Bearing mode set up**” (page3-12) to setup bearing mode.

[Bearing mode] can be changed directly in the lower light of the screen, with trackball and [ENT] key, without using menu function.

1 Push [ERBL] key and ERBL is displayed.

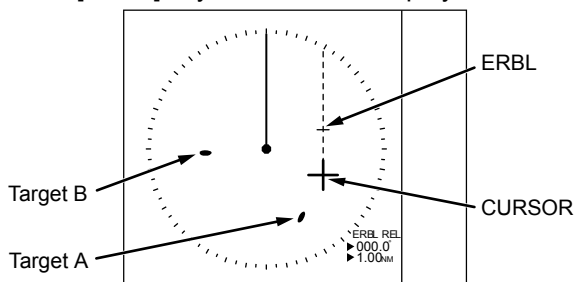

2 By adjusting Focus CURSOR to the target A, the measurement of the distance and bearing from the target A to the target B can be obtained by using [VRM] knob and [EBL] knob.

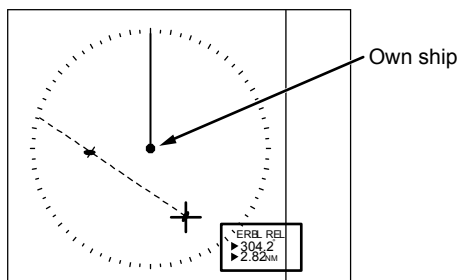

3 Pressing [ENT] key (while pressing [OFF] key) returns CURSOR to the reference point position. Thereafter, it is possible to measure the distance/bearing from the reference point position.

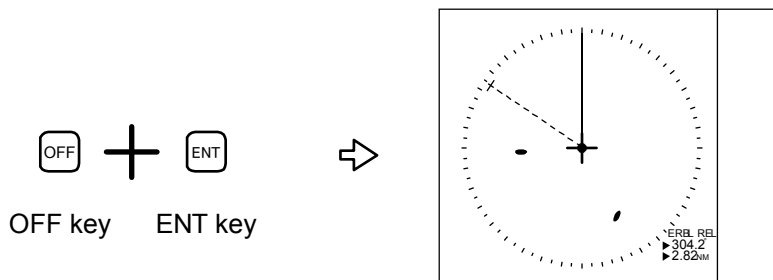

## 2.12 Change display color (Day/Night)

This function is used for changing of the default display color of day and night.

[DAY/NIGHT] can be changed directly in the upper right of the screen, with trackball and [ENT] key, without using menu function.

- 1 Press [MENU] key to display “Menu”.  
 Select [BRILL] => [COLOR] => Select the mode (day or night) whose display color is to be changed. After selection, press [ENT] key.  
 Select [BRILL] => Select the item to set up => After selecting of the “Display color”, press [ENT] key.

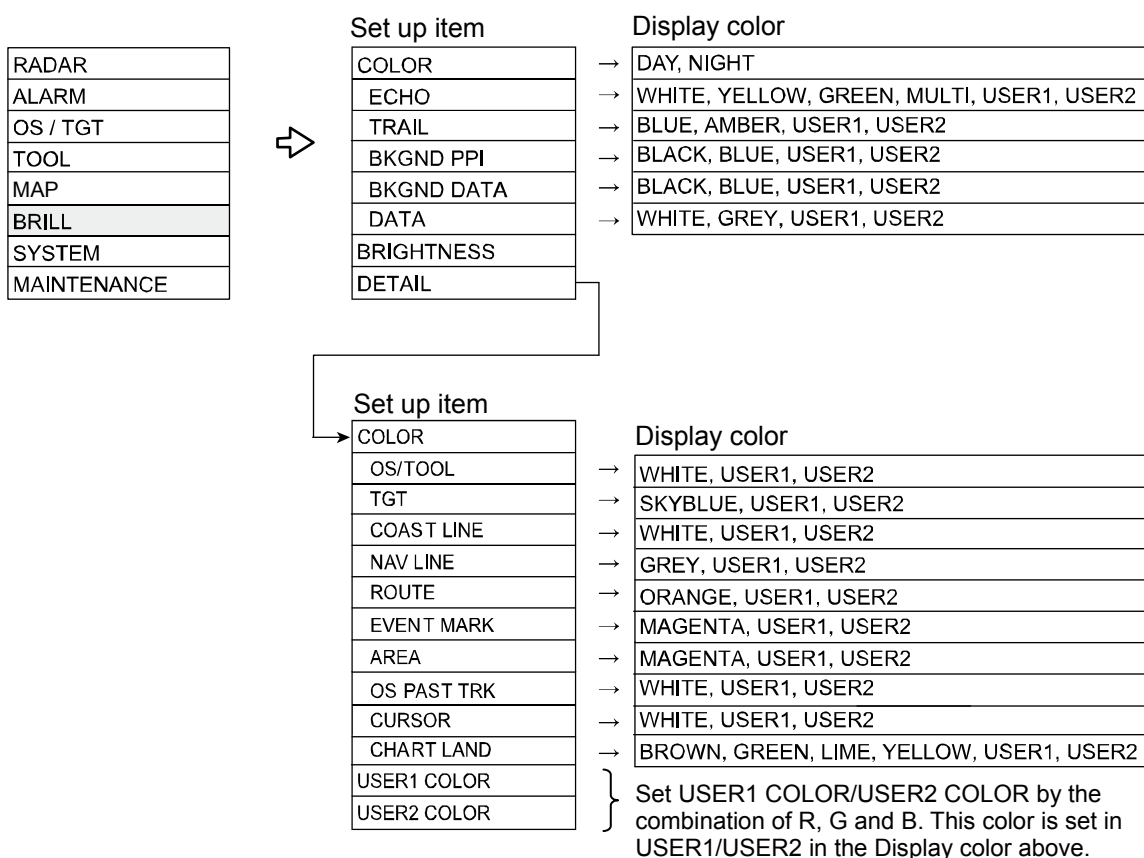

## 2.13 Remove the heading line

This function is used when a target is overlapped with a heading line and hard to be distinguished.

- 1 Press [OFF] key to temporarily hide the heading line.  
 By safety reason, the heading line disappears only while the key is kept pressed. (It is not possible to keep it removed.)

\* This function removes also [MAP], such as COAST LINE, NAV LINE, ROUTE, MARK, and AREA.

☞ Refer to “MAP” (page4-25).

## 2.14 Relocate antenna position (Off-centering)

This function is used for getting broad outlook of heading.

Two types of "OFF CENTER" direction are available.

[CURSOR]: Off-centering to CURSOR direction.

[OPPOSITE]: Off-centering to the stern direction.

\* When [AUTO OFF CENT] is used, [CURSOR] is unavailable

**1** Press [MENU] key to display "Menu".

Select [RADAR] => [OFF CENT POINT] and press [ENT] key after selecting the set-up value.

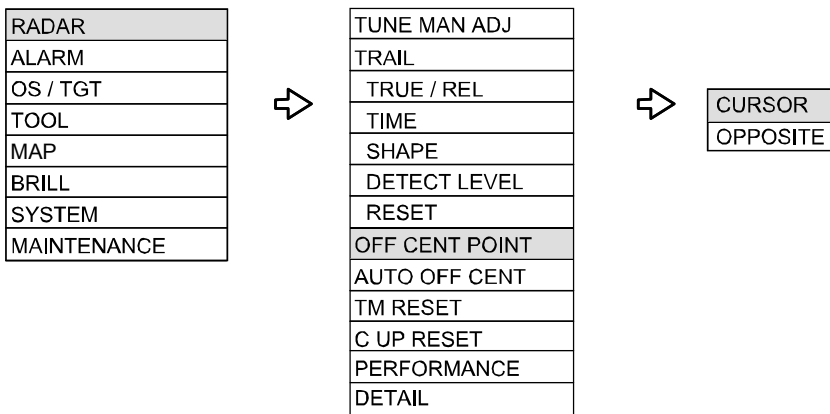

**2** Off-centering relocation is executed by pressing [OFF CENT] key.

**3** The difference of [CURSOR] and [OPPOSITE] are as follows.

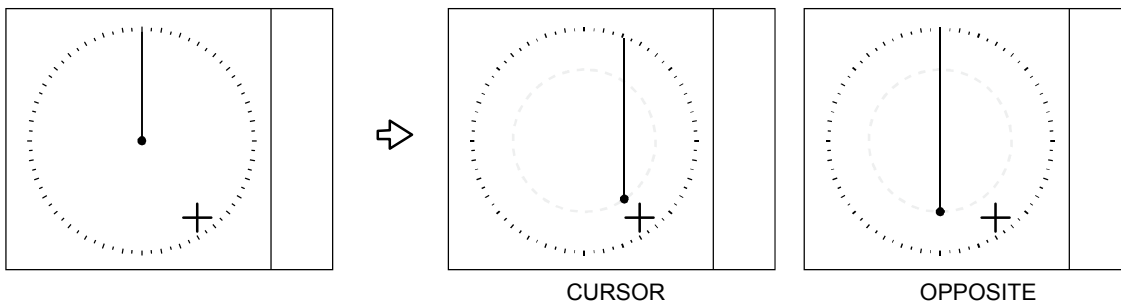

**4** In addition, [AUTO OFF CENT] function is provided.

[AUTO OFF CENT] is a function to display allowing wide range of view of echo in front of own ship in occasion of turning in C UP<sub>RM</sub> and N UP<sub>RM</sub> mode even when the course is changed.

\*Relocation area is limited. (See relocation area as shown below.)

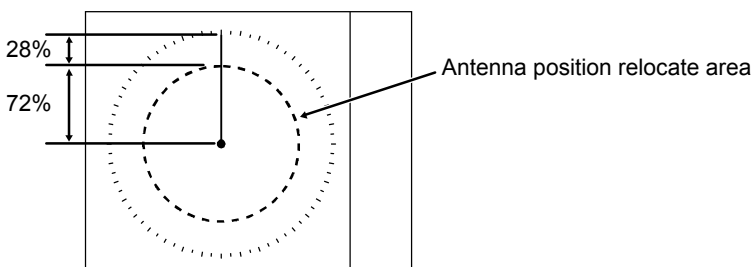

## 2.15 Select screen display (Display mode)

The display mode is a combination of the bearing indication and the target motion indication.

The bearing is indicated in three ways: [HUP], [CUP] and [NUP].

The target motion is indicated in two ways: [RM] and [TM].

•Your ship heading is assumed 65°in following [HUP], [CUP] and [NUP] descriptions.

- 1 Press [MODE] key. The display changes by the following order on pressing the [MODE] key. Current display mode is displayed at the upper left of the display.



### For H UP (Head up mode)

Heading line is always oriented toward the top of the screen.

This mode is based on the bow of the ship and is suitable to monitor targets because targets are seen as they are in navigating own ship.

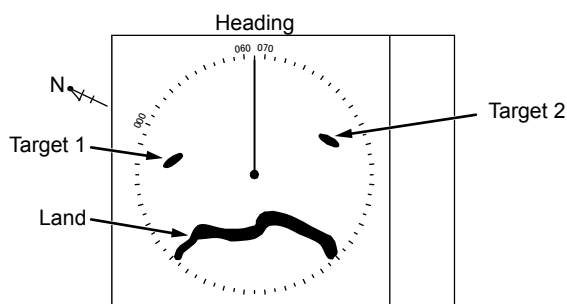

The heading line to the top of the screen can be also changed from ship's bearing.

☞ Refer to "H UP OFFSET" (page4-4).

For H UP (Head up mode)

**For C UP (Course up mode)**

The course to a waypoint is the heading line at the time of selecting "C UP", and the specified course is oriented toward the top of the screen.

This mode is used to navigate along the specified course.

It easily shows any deviance of own ship from the specified course.

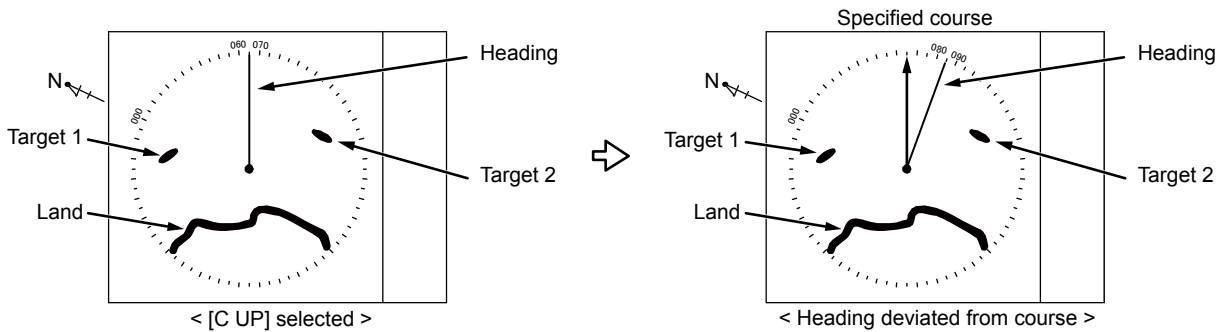

**For N UP (North up mode)**

This mode always keeps true north at the top of the screen.

A north oriented representation makes it easy to correlated with a chart.

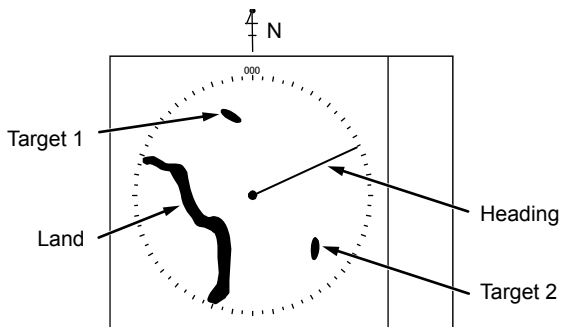

### **For relative motion (RM) and true motion (TM)**

Relative motion fixes your antenna position at the center of the display, and the targets that surround your antenna position move.

Your antenna position is displayed at the center. So, while the ship is steaming, the fixed targets such as the land also continue to move.

In the true motion, the antenna position moves on the screen based on the own ship's direction and speed.

As a result, the not moving targets stay fixed on the display, and all the moving targets move on the display.

\* The heading always continues to move. So, no true motion [TM] is available for [H UP].

**Relative motion (RM):** The antenna position is fixed and the other surrounding targets move on the display.

This is useful for monitor the surrounding situation with respect to own ship's position.

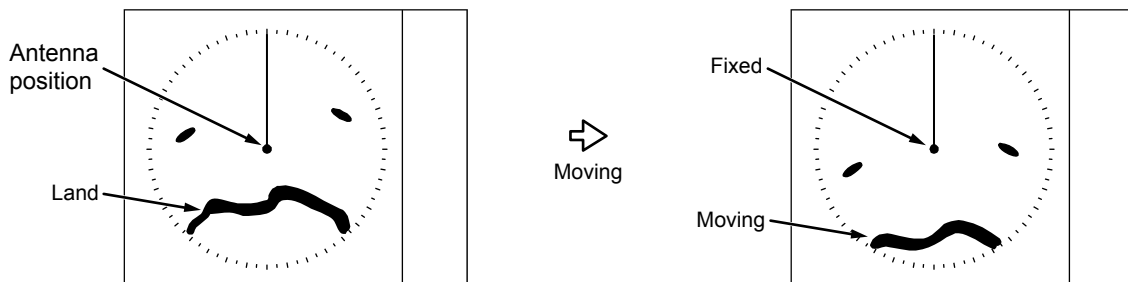

**True motion (TM):** The antenna position on the screen moves according to its speed and tidal current. Stationary targets are fixed on the display. This mode is useful to monitor your position with respect to the fixed targets such as land.

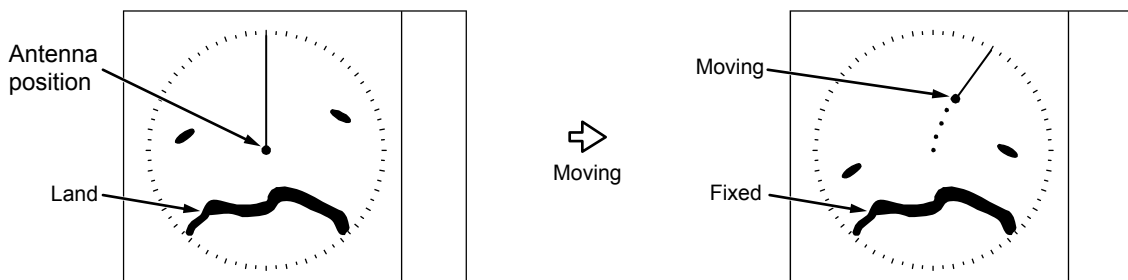



When own ship moves out of the movable range during the true motion, own ship is reset to the course over water or to the opposite direction of the course over ground.

☞ Refer to "TM RESET MODE" (page4-2).

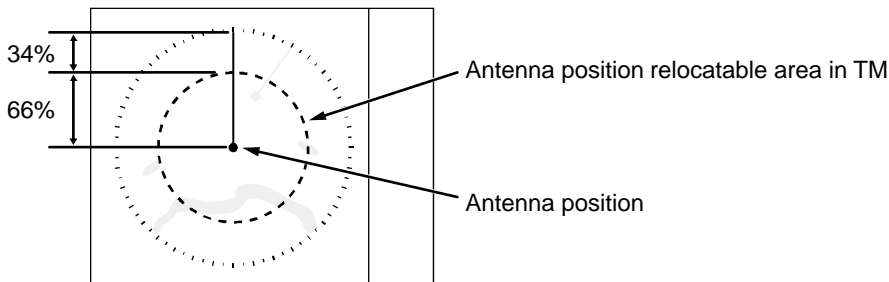

### Reset true motion

Antenna position can be relocated before own ship moves out of antenna position relocatable area in true motion.

1 Press [MENU] key to display "Menu".

Select [RADAR] => [TM RESET] and then press [ENT] key.

RADAR
ALARM
OS / TGT
TOOL
MAP
BRILL
SYSTEM
MAINTENANCE



TUNE MAN ADJ
TRAIL
TRUE / REL
TIME
SHAPE
DETECT LEVEL
RESET
OFF CENT POINT
AUTO OFF CENT
TM RESET
C UP RESET
PERFORMANCE
DETAIL

## 2.16 F (Function key) usage

For quick function access, this radar is provided with six dedicated function keys (“F1”, “F2”, “F3”, “F4”, “F5” and “F6”). You can switch to a pre-specified function by pushing each key.

1 Press [MENU] key to display “Menu”.

Select [MAINTENANCE] => [STARTUP] => [F1], and then press [ENT] key after selecting the setup value.

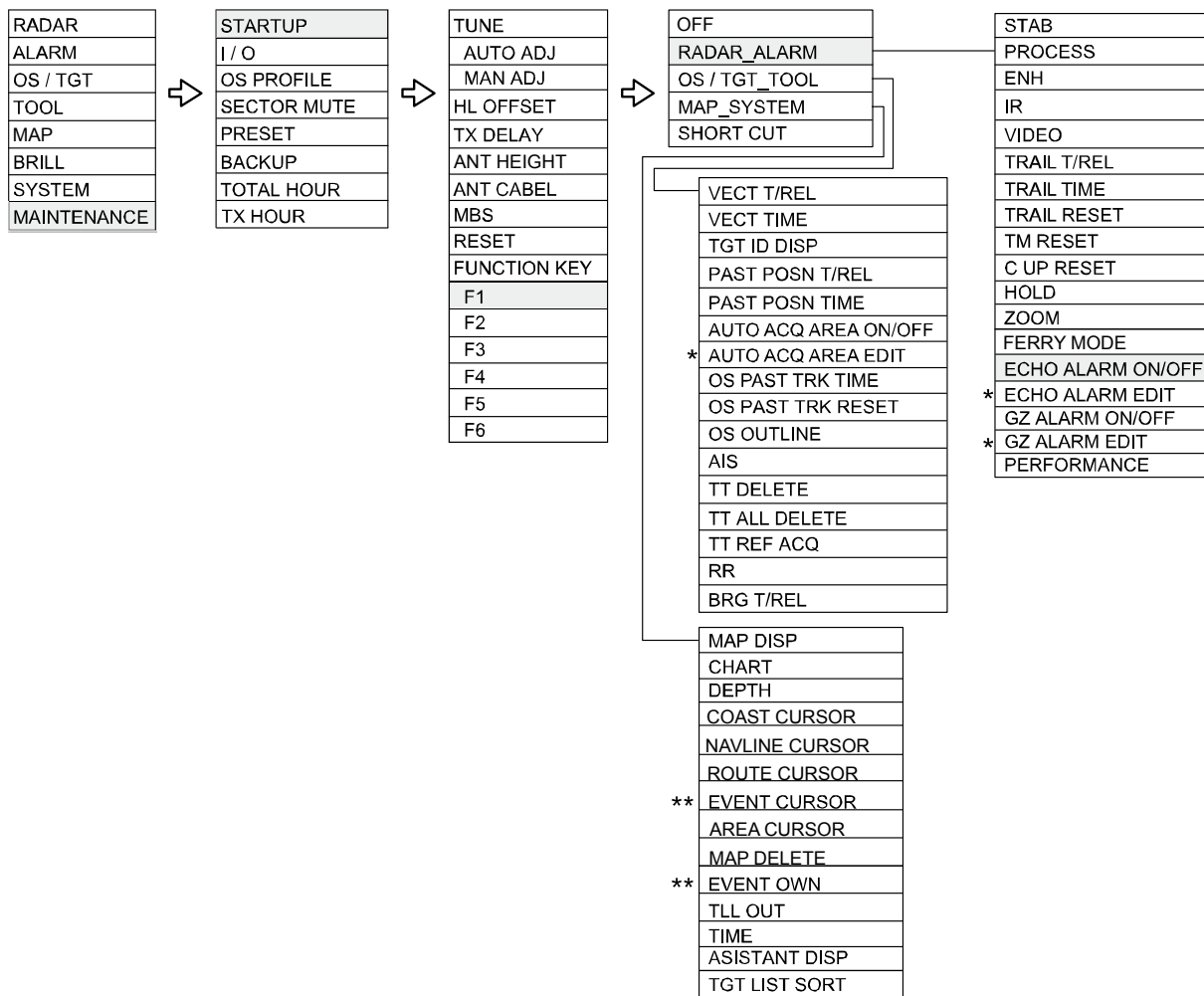

\*No numerical value is displayed in function key operation.

\*\* The position of the cursor and own ship's position are recorded as event markers.

☞ Refer to “EDIT MARK SHAPE” (page4-29) for designation of mark shape.

2 The same procedure as step 1 is applied for [F2], [F3], [F4], [F5] and [F6], by selecting each item and pressing the [ENT] key.

[SHORT CUT]: Press F key only once. This function makes it easy to access a menu item that was previously set up.

- 1** Select F key to be assigned as short cut key (for example [F1] key).
- 2** Move to the menu that you want to assign for short cut function.
- 3** Push a [F1] key by holding a [OFF] key.
- 4** The setup is complete when beeping the buzzer beeps for two second.
- 5** Push [F1] key without menu, and then assigned short cut menu will appear immediately.

## Chapter 3 Primary operations (For menu)

### 3.1 Menu usage

#### Display and remove menu

Press [MENU] key and "Menu" is indicated at the right of the display.

"Menu" display is removed by pressing the [MENU] key.

#### Select menu item

- 1 Press [MENU] key and "Main" menu is shown on the display. Select one of main menu items by moving the trackball up or down.
- 2 Move the trackball to the right after selection of the main menu item and the sub menu is shown on the display.
- 3 Select a sub menu item by moving the trackball up or down.
- 4 Move the trackball to the right after selection of the sub menu item and the then the selection of designated value is shown.
- 5 Select designated value then press [ENT] key.  
\*Pay attention that the actual change is not executed until [ENT] key is pressed.
- 6 Move the trackball to the left to return to the previous menu.  
The menu is closed when [MENU] key is pressed.

<Example of menu display>

MENU			
RADAR	>		
ALARM	>		
OS / TGT	>		
TOOL	>		
MAP	>		
BRILL	>		
SYSTEM	>		
MAINTENANCE	>		

⇒

MENU			
> TOOL			
RR		OFF	
BRG TRUE / REL		REL	
CURSOR SHAPE		+	
PI			
LINE		1	
DISP		ON	
START RNG		1.00NM	
END RNG		2.00NM	
PI DISP SIDE		FULL	
EBL1 OFFSET		RM	
EBL2 OFFSET		RM	
DETAIL		>	

⇒

MENU			
> TOOL			
RR		OFF	
BRG TRUE / REL		OFF	
CURSOR SHAPE		ON	
PI			
LINE		1	
DISP		ON	
START RNG		1.00NM	
END RNG		2.00NM	
PI DISP SIDE		FULL	
EBL1 OFFSET		RM	
EBL2 OFFSET		RM	

\* As "Menu" setup value is stored in the non-volatile memory inside the radar. Therefore, no setup operation is required after power is turned on.

\* About the shaded menu:

[INTER SWITCH] in [SYSTEM] menu, and [SECTOR MUTE], [BACKUP], [TX HOUR] and [TOTAL HOUR] in [MAINTENANCE] menu are not available during transmission, and they are all shaded.

## 3.2 STAB MODE

STAB MODE is a function to select speed for movement calculation for True trail, TT (ARPA), Past position and True motion (TM).

 Refer to “**Display ship’s trail**” (page3-9)

 Refer to “**Target tracking TT (ARPA)**” (page3-24)

 Refer to “**PAST POSN: Past position**” (page3-17)

 Refer to “**For relative motion (RM) and true motion (TM)**” (page2-25)

SEA: Stabilization mode using speed over water.

GND: Stabilization mode using speed over ground.

[STAB MODE] can be changed directly at the upper left of the screen.

When SDME or EPFS is not usable by any reason, it is possible to get the speed over ground by setting reference target.

 Refer to “**Reference target acquisition**” (page3-26)

### SEA (Sea stabilization)

SEA stabilization uses CTW (course through water) and STW (speed through water) referenced to water. Accordingly course and speed indication at the top right side of the screen becomes CTW/STW.

- STW is relative speed of the ship against water surface in the heading direction.
- Information from SDME (speed and distance measuring equipment) like LOG is inputted by serial data (VBW or VHW).
- Single axis water log indicated as LOG on the screen cannot detect the effect of leeway.
- When speed information is interrupted for 30 seconds from SDME by any reason or VBW water status flag is invalid, speed indication becomes XXXX by red symbol.

In this case, speed can be entered manually.

Manual speed input.

- 1** Press [MENU] key, and [Menu] display is shown on the screen.  
Select [MAINTENANCE] => [I / O] => [STW] => [MAN], and then press [ENT] key.
- 2** Press [MENU] key to erase menu.
- 3** Move cursor to the window on the right side of STW MAN in the top right side of the screen by the trackball.
- 4** Press [ENT] key to get ready for speed entry. Enter speed by trackball.
- 5** Press [ENT] key to fix the input.

### **GND (Ground stabilization)**

---

GND uses COG (course over ground) and SOG (speed over ground) referenced to the ground.

Accordingly course and speed indication at the top right side of the screen becomes COG/SOG.

- SOG is the absolute speed of the ship with reference to the land located in the course direction.
- Two-dimensional GND SDME device like dual axis LOG and EPFS (electronic position fixing system) give the information for serial input.
- If both serial sentence data of VTG (EPFS) and VBW (SDME) are available, then VBW is given priority.
- If the failure of EPFS or SDME interrupts the speed information for 30 seconds or if the ground status flag or VTG indicator flag is invalid, then the numeral indication of COG/SOG becomes XXXX by red symbol.
- If SDME or EPFS is not usable by breakdown or any reason, then COG/SOG can be obtained by setting Reference target.

 Refer to “**Reference target acquisition**” (page3-26)

### 3.3 Radar signal correlation (PROCESS)

There are 3 signal processes; PROCESS 1, PROSCCESS 2 and PROCESS 3. The signal processing consists of residual images processing and signal average processing to eliminate such clutter as sea surface or rain reflection.

For normal functioning of the signal processing, external signals of ship's bearing and speed are required.

Signal process 1 is effective for detecting the ships moving at a speed higher than 15 kn.

Signal process 2 is effective for detecting the ships moving at a speed lower than 15 kn.

Signal process 3 is highly effective to detect buoys such as course indicators and floats. However, moving ships may disappear.

- 1 Move the cursor to set value window of [PROCESS] at the upper right part of the screen.  
Press [ENT] key repeatedly until the desired value appears.
- 2 Turn the [SEA] and [RAIN] knobs to adjust the clutter to a dark level not to get in the way of detecting targets.

#### • PROCESS 1:

This is the process to get stable display of targets per every rotation of an antenna. It is effective to detect moving ships at high speed.

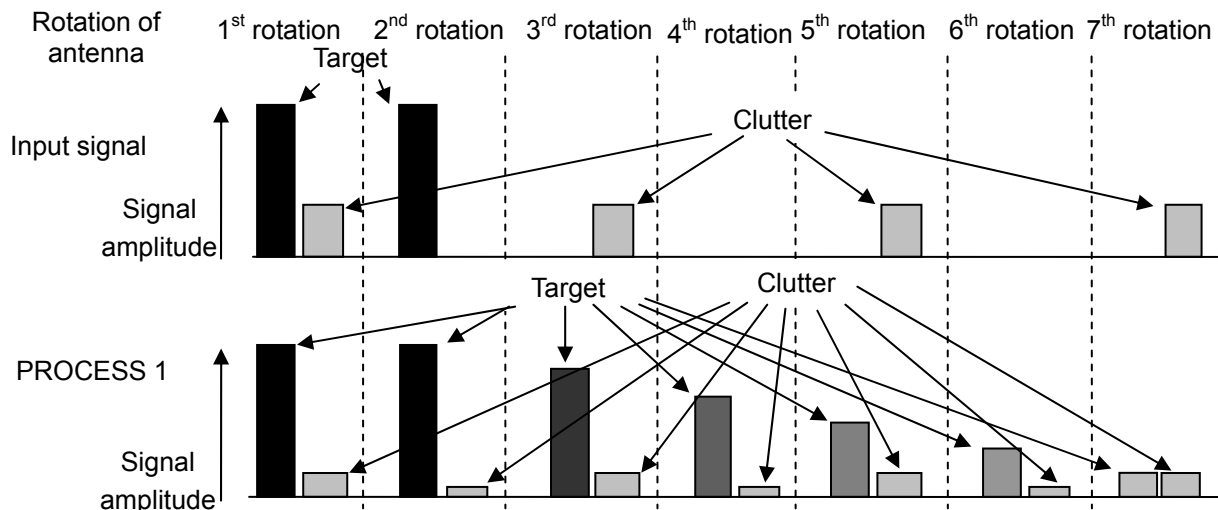

PROCESS 1 is the processing characterized by residual image effect and has also depressing effect on clutter as compared with input signal.

• **PROCESS 2:**

This is to average images of 3 rotations of an antenna. It is effective to detect ships moving at a speed lower than 15 kn.

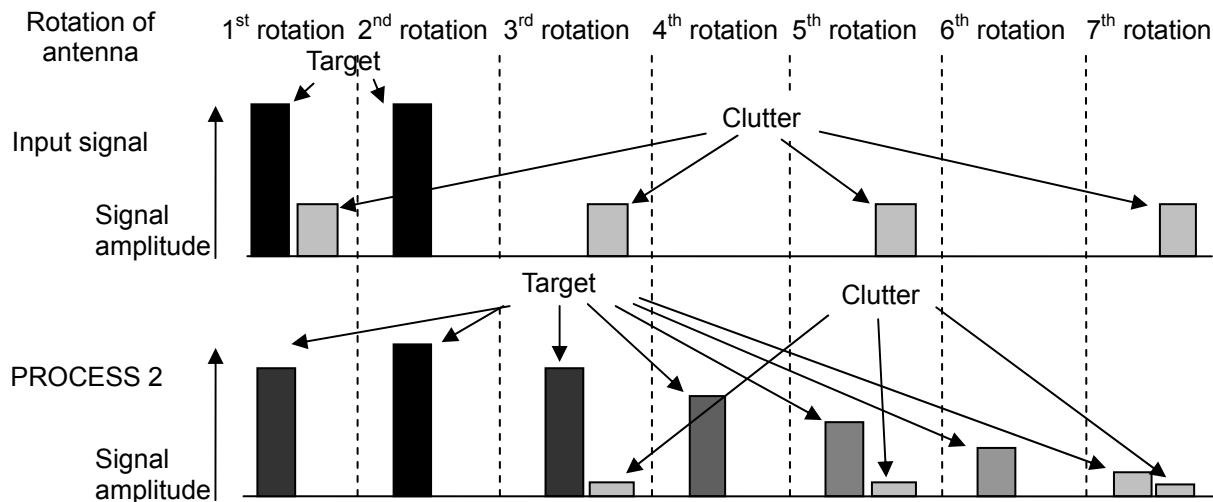

PROCESS 2 is the combination of average processing and residual effect. It has improved identification capability of targets and clutter as compared with PEOCESS 1.

• **PROCESS 3:**

In this process, images of 6 rotations of an antenna will be averaged. It is effective to detect course indicators and floats in the waves.

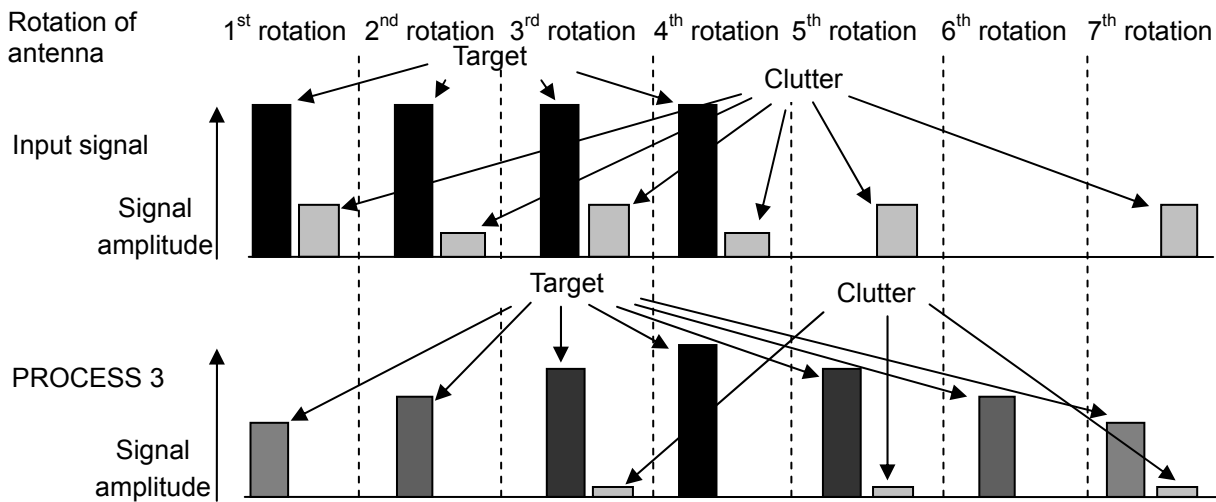

PROCESS 3 is average processing. It has improved identification capability of targets and clutter as compared with PROCESS 2. However, moving targets may be displayed weakly.



### 3.4 Enhance target (ENH)

This is the function to enlarge an image in the direction of distance/bearing.

Small ships and remote targets can be enlarged to be easily visible.

[ENH] can be changed directly at the upper light of the screen.

- 1 Move the cursor to set value window of [ENH] at the upper right part of the screen.  
Press [ENT] key repeatedly until the desired value appears.

- The setting value can be selected from “OFF, 1, 2 and 3” and the larger value applies stronger enhance effect.

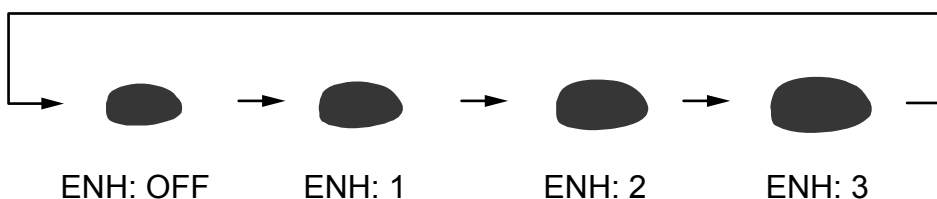

\*The enlargement of targets has effect on all echoes. So, a large target such as land is also enlarged. Consequently, land and a small target may be sometimes seen as a single target. Pay attention to that.

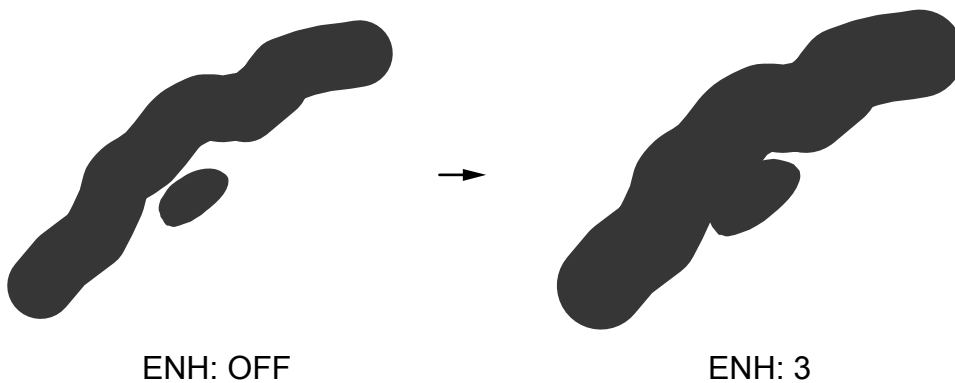

### 3.5 Interference rejection (IR)

This feature is used to reject radar interference from other radars.

Radar transmissions in the same frequency band can cause interference noise on the display depending on its transmitted power. This noise pattern appearance varies case by case, but is usually spiral in shape or like the spokes of a wheel in shape.

This equipment can reduce this phenomenon.

[IR] can be changed directly at the upper light of the screen.

[IR] is also effective to reduce second time echo phenomenon.

**1** Move the cursor to set value window of [IR] at the upper right part of the screen.

Press [ENT] key repeatedly until desired value appears.

- The setting value can be selected from “OFF, 1, 2, 3, 4, 5” and the larger value applies stronger interference rejection effect.
- Note: Too much removal effect may also remove small targets. Pay attention to that.

### 3.6 Video mode (VIDEO)

This is a function to change the relation between the strength of signal of target echo and their display gradation.

At [VIDEO 0], the difference of signals strength between dark images and bright images becomes larger. As the numerical figure becomes larger as [VIDEO 1], [VIDEO 2] and [VIDEO 3], the difference in signal strength becomes smaller.

At [VIDEO 4], the difference of signal strength becomes gradually smaller in the range at close to 5 NM and becomes constant at 5 NM or higher. When the difference of signal strength is large, it will be easy to display clutter at darker level and targets at brighter level.

[VIDEO] can be changed directly at the upper light of the screen.

- 1 Move the cursor to the setup value window of [VIDEO] at the upper right part of the screen. Press [ENT] key repeatedly until desired value appears.

When the difference of signal strength is small, images becomes sharper.

However, signal strength from small ships and buoys is weak, and the difference between clutter and them is not large enough.

Therefore, it is necessary to display the clutter not to get in the way and not to overlook small ships and course buoys. Therefore, it is recommended to use [VIDEO 1] or [VIDEO 4].

### 3.7 Display ship's trail

Displaying the target ship's trail is done as follows.

Two types of display mode, relative display (REL) and true display (TRUE) are available.

At the start of test, "TRAIL" characters at lower left of the screen change to yellow.

\* The trail by its nature records and displays past images. The trail does not display an image just after being transmitted.

In addition, after the change of [TIME], or after the change of two or more steps of [RANGE], the trail does not display an image, because the record is reset (erased).

\* The trail can be changed directly at the lower left of the screen, with trackball and [ENT] key, without using menu function.

- 1 Press [MENU] key, and [Menu] display is shown on the screen.

Select [RADAR] => [TRUE / REL], and then press [ENT] key after selecting the setup value.

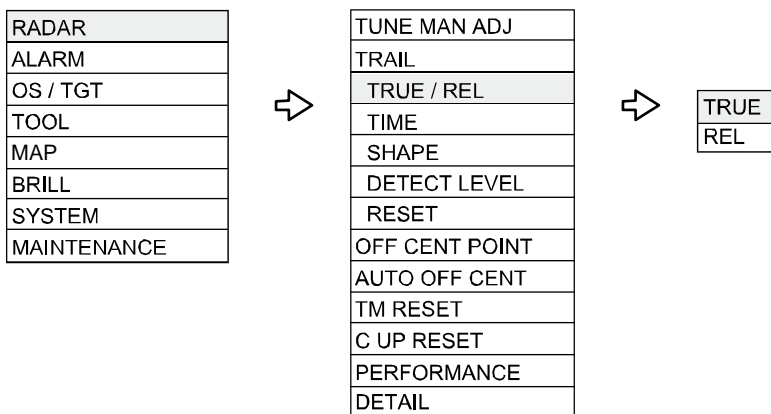

\* [TRUE/REL] is in common with [PAST POSN]. So, if you change one part, the other part will change accordingly.

☞ Refer to page3-17

- 2 There are additional set up items, [TIME], [SHAPE], [DETECT LEVEL] and [RESET].

[TIME]: This is to set up the time of the trail to be displayed by setting the time up to how many minutes before from now.

[SHAPE]: Three types of shapes, [CATERPILLAR], [TADPOLE] and [FIREBALL] as shown below.



[DETECT LEVEL]: This is to set up echo level of trail to be recorded.

[RESET]: Erase current record and display of trail and then start new record and display of trail.

For setting of trails, [RANGE KEEP], [C UP KEEP], [MODE KEEP], [MOVE] are also available.

☞ Refer to "TRAIL" (page4-3).

**Relative display (R)**

The target trail is displayed as result of sum of vector (course and speed) of the target ship and your ship. When your ship is on the projected course of this trail, it shows that a collision may occur in future. This display is useful to help detect a dangerous situation.

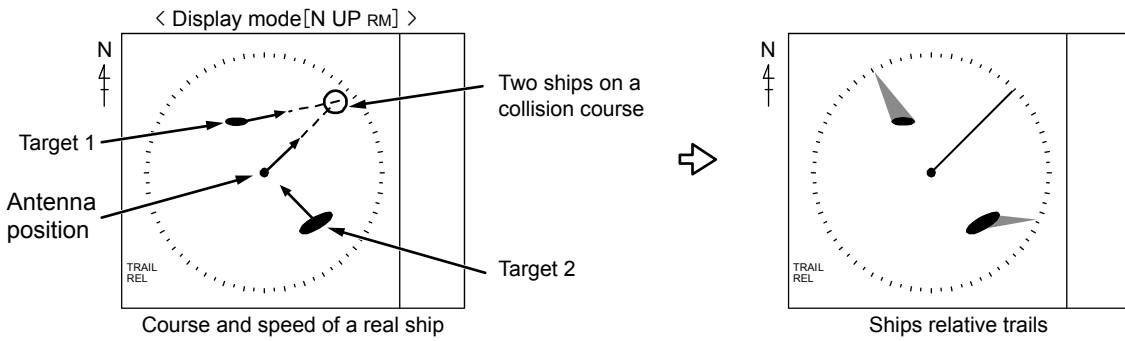

Target 1, whose trail is overlapping the EBL, is a dangerous target while the Target 2 is not. If trail setting is six minutes, and if the trail length is equal to the distance between the antenna position and Target 1, then the collision will occur after six minutes.

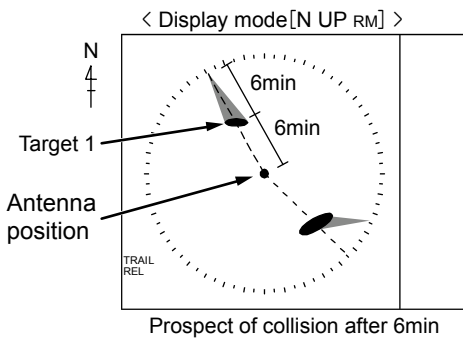

**True display (T)**

This mode displays the trail of the moving target over a specified time interval independently from own ship's movement.

This mode is used to monitor the bearing and speed of the target.

No trails of fixed targets such as land are drawn on the display.

The amount of movement of all ships, own ship, Target 1 and Target 2 are drawn as trails.

The land does not move, so its trail is not drawn.

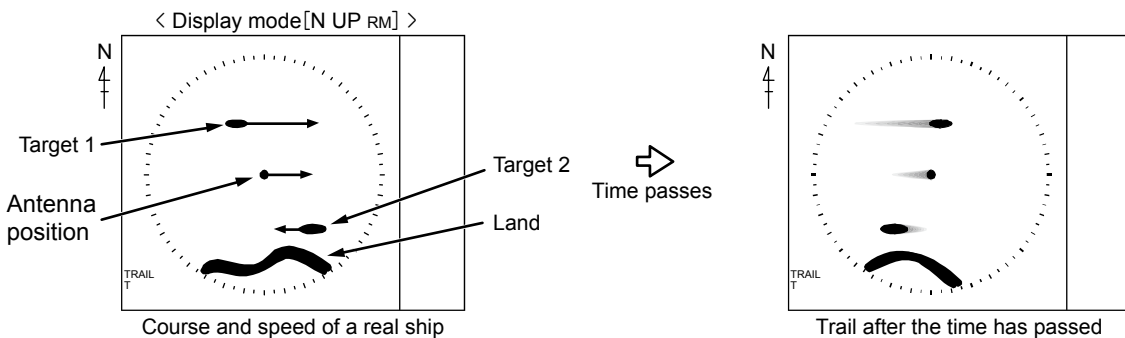

### 3.8 Display range rings (RR)

The range rings (RR) are markers displayed at the specified distance from reference point.

☞ Refer to “**Setup own ship profile**” (page1-5) to setup reference point.

It is used as a rough indication of the distance from a target.

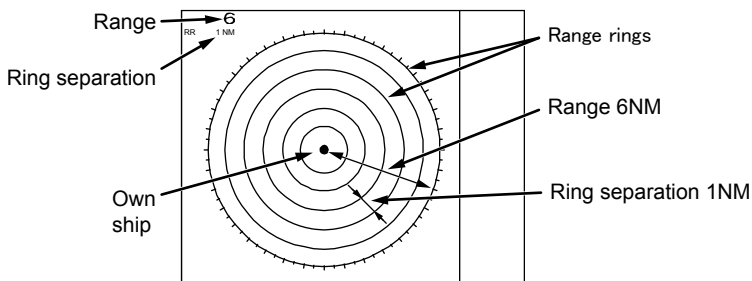

- 1 Press [MENU] key to display “menu”.  
Select [TOOL] => [RR] => [ON], and then press [ENT] key.

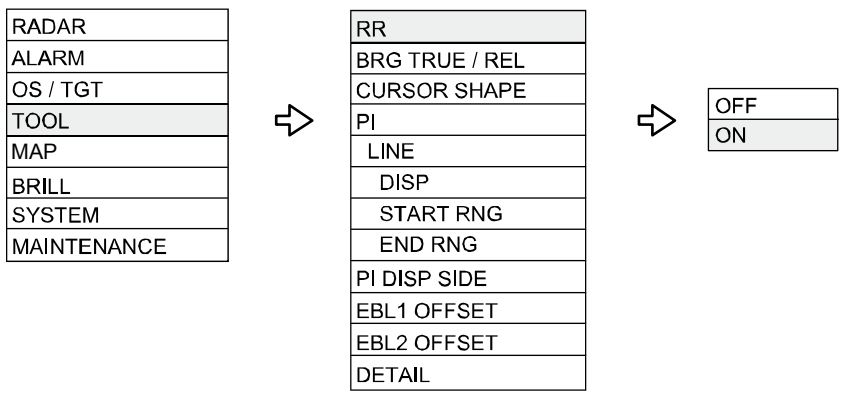

\*[RR] display can be changed directly in the upper left of the screen, with trackball and [ENT] key, without using menu function.

\*0° of the range rings indicates North direction when [BRG TRUE / REL] is TRUE while heading direction when [BRG TRUE / REL] is REL.

☞ Refer to “**Bearing mode set up**” (page3-12)

### 3.9 Bearing mode set up

This menu is used to change the bearing mode in “EBL”(☞ page2-15), “PI”(☞ page2-17), “ERBL”(☞ page2-20), “bearing scale”(☞ page2-6) and “CURSOR”.

The settings available in the true bearing with the true north as 000 degree, and in the relative bearing with the heading as 000 degree.

[EBL], [PI], [ERBL], [CURSOR] can be changed directly in the screen.

- 1 Display “Menu” by pressing [MENU] key.

Select [TOOL] => [BRG TRUE/REL] => then press [Enter] after selecting the setup value.

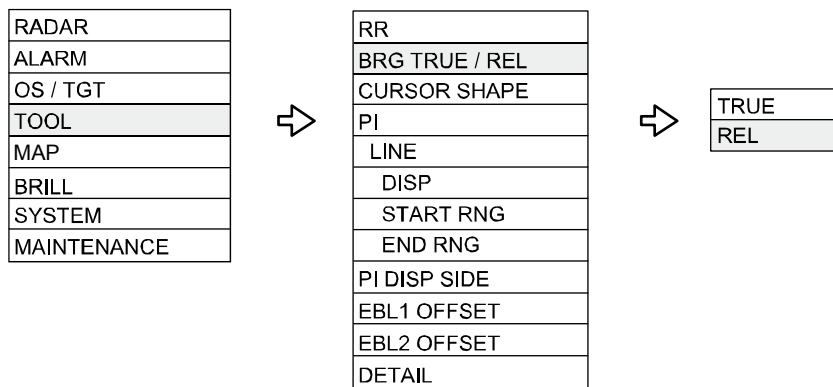

### 3.10 Echo alarm

This function is used to monitor hazardous targets such for collision prevention.

#### \*Collision avoidance

It is strongly recommended to maneuver the ship for collision avoidance based on sure and dependable SOG and COG information.

This is because ship's heading and running speed against water may be different from the actual ship's movement due to foreign or mostly natural environmental effect such as wind, current, wave etc.

☞ Refer to "COG / SOG" (page4-44)

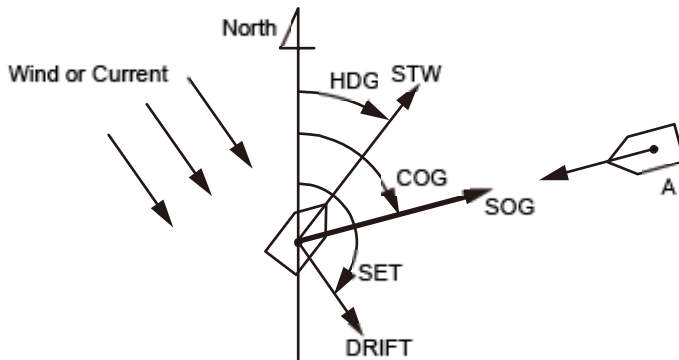

- 1 Press [MENU] key to display "Menu".  
Select [ALARM] => [ECHO ALARM] => [EDIT], and then press [ENT] key.

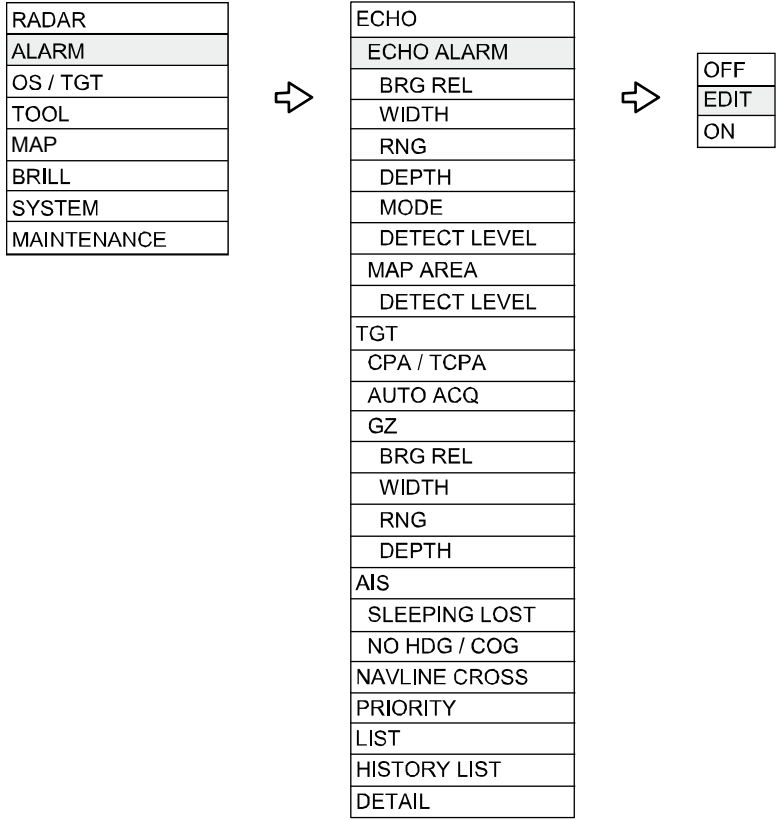



- 2 The items to be selected are [BRG], [RNG], [WIDTH], and [DEPTH].

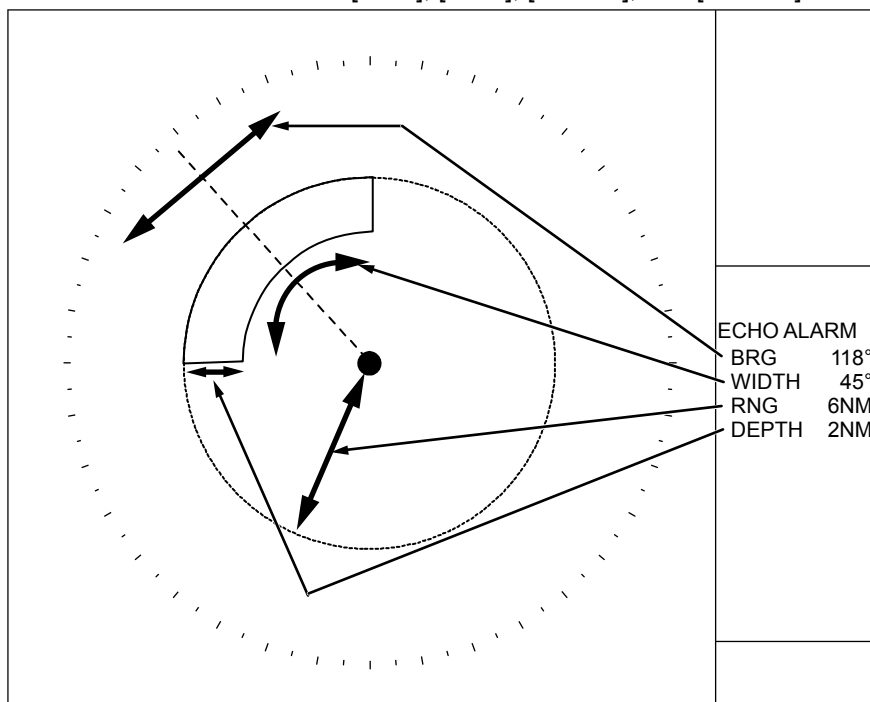

[VRM] knob and [EBL] knob are used for setup.

- 3 Press [EBL1] or [EBL2] key, and then Select an item to be set between [BRG] and [WIDTH] by using [EBL] knob.

In the same way, press [VRM1] or [VRM2] key, and select an item to be set between [RNG] and [DEPTH] by using [VRM] knob.

The selected item is shown with a ► symbol at the left of numerical indication at the lower left of the screen.

- 4 Select [ECHO ALARM] => [ON], and then press [ENT] key.

- 5 There are additional items, [MODE] and [DETECT LEVEL].

MODE [IN]: When the echo enters a specified zone, an alarm sounds.

[OUT]: When the echo leaves a specified zone, an alarm sounds.

DETECT LEVEL: It designates echo strength to determine an alarm sound. When the level is set too low, noise may be responded.

### 3.11 Target tracking TT (ARPA) / AIS common items

This feature provides auto tracking of the target and will record and display its course and speed as a vector.

#### VECTOR

The course and speed are indicated as vector after tracking is established.

Two types of display mode are available: relative display (REL) and true display (TRUE).

REL: This vector adds the course/speed of a target to the course/speed of own ship.

If the vector is directed to the own ship, possibility of collision exists.

It shows danger of collision at a glance and is useful to avoid collision.

TRUE: This vector shows the course/speed of a target only, irrespective of the own ship.

- 1 Press [MENU] key, and [Menu] display is shown on the screen.  
Select [OS/TGT] => [VECT TRUE / REL], and then press [ENT] key after selecting the setup value.

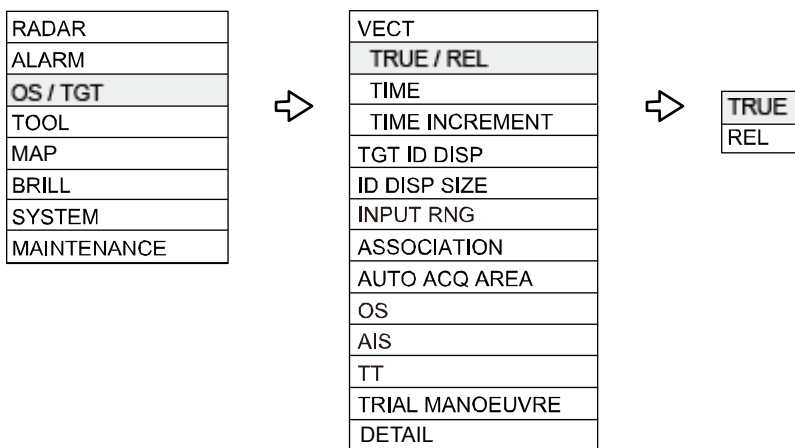

- 2 In addition, there are [TIME] and [TIME INCREMENT] setups.

[TIME]: It designates length of vector by time. When [TIME] is specified by 1 min, the vector is displayed to the position that will be reached in 1 min by present target speed.

[TIME INCREMENT]: This vector displays the division number of time divider. When the setup value is 2, vector is 1/2 and the parting line is displayed at a half-length location of vector.

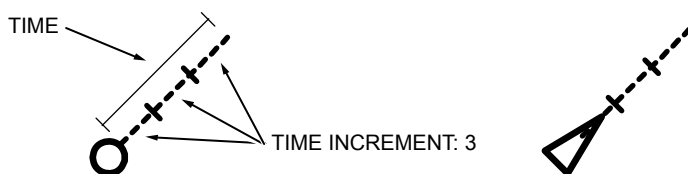

\* [TRUE / REL] and [TIME] can be changed directly at the upper right of the display screen, with trackball and [ENT] key, without using menu.

**CPA/TCPA**

To avoid collision, it sets up LIMIT CPA (closest point of collision) and LIMIT T CPA (time to CPA).

[LIMIT CPA] and [LIMIT T CPA] can be changed directly at the upper right of the screen.

- 1 Move the cursor to set the value window of [CPA] at the upper right of the screen.  
Press [ENT] key and change the setting value with the trackball.  
Press [ENT] key to validate after changing the setup value.
- 2 In addition, [LIMIT T CPA] is used to specify limit by time.

**TGT ID**

ID can be displayed with TT (ARPA) or AIS target.

[NUMBER] and [LABEL] are used as ID.

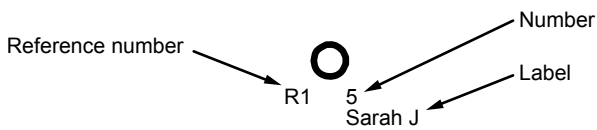

☞ Refer to “Reference target acquisition” (page3-26) about Reference number.

- 1 Press [MENU] key, and [Menu] display is shown on the screen.  
Select [OS/TGT] => [TGT ID DISP], and then press [ENT] key after selecting the setup value.

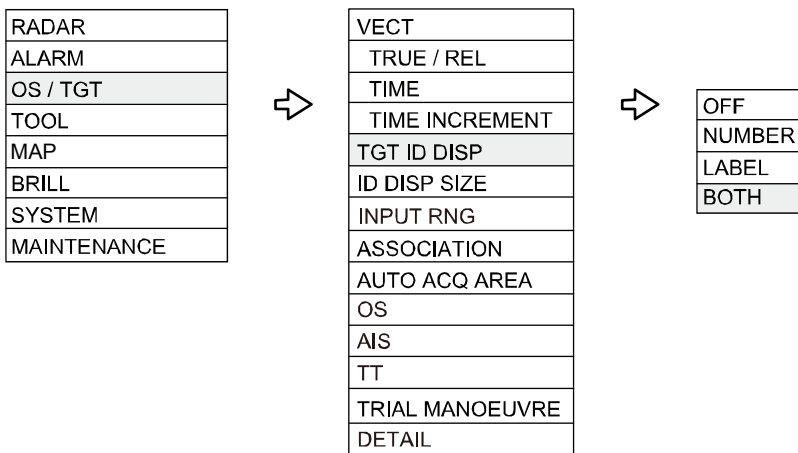

- 2 In addition, [ID DISP SIZE] is used to specify display size.

**PAST POSN: Past position**

The past position of TT (target tracking) and AIS (activated target) can be displayed.

\* The past position by its nature records and displays past positions. Immediate display is impossible after the start of TT (ARPA) and after the change from AIS sleep target to active target.

In addition, when [TIME] is changed, a record is reset (erased). So, immediate display is impossible.

During “PAST POSN” recording, [PAST POSN BUILD UP] message in yellow characters is displayed in [TGT INFO] column of mid right of the screen.

- 1 Move the cursor to set value window of [PAST POSN] upper right part of the screen. Press [ENT] key to select T or REL.

\*As [TRUE/REL] is in common with [TRAIL] (☞ Refer to page3-9). So, if you change one part, the other part will change accordingly.

- 2 In addition, [PAST POSN TIME] item designates recording length.

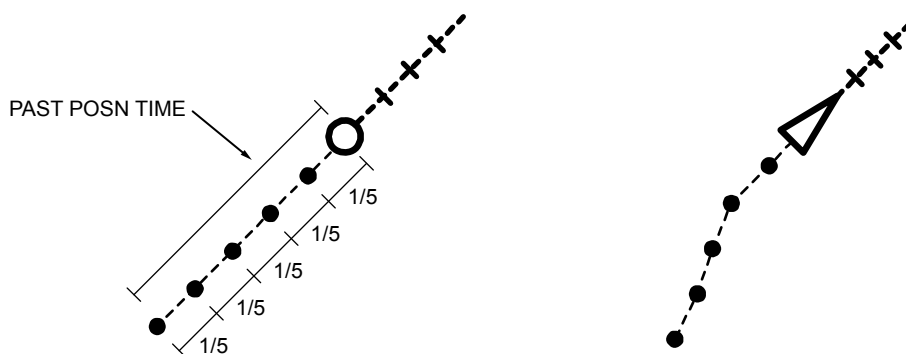

Up to five record points are available.

## ASSOCIATION

When an AIS target and a tracked target of TT (ARPA) are regarded the same target, it is automatically associated to a single target.

Select priority of the association with either AIS or TT (ARPA).

If the low-speed ship is associated and displayed with TT priority, then HDG may be unstable. So, the display with AIS priority is recommendable.

- 1 Press [MENU] key, and [Menu] display is shown on the screen.  
 Select [OS/TGT] => [ASSOCIATION] => [ASSOCIATION], and press [ENT] key after selecting the setup value.

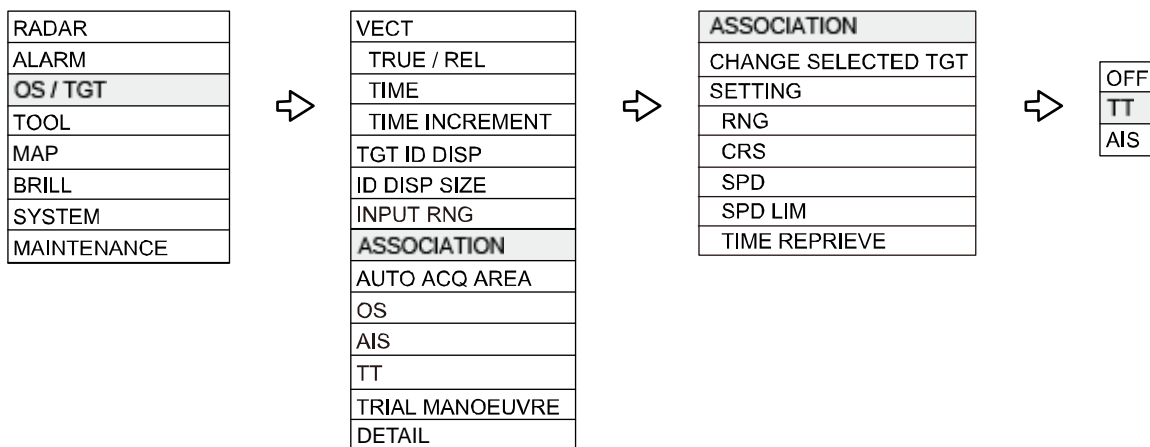

OFF : Association is turned off.

TT : Symbols of both TT (ARPA) and AIS are associated to TT (ARPA). However when the target of AIS is sleeping target it is not associated.

AIS : Symbols of both TT (ARPA) and AIS are associated to AIS. However when the target of AIS is sleeping target it is not associated.

[ASSOCIATION] can be changed directly at the upper right of the display screen, with trackball and [ENT] key, without using menu function.

In addition, [CHANGE SELECTED TGT] and [SETTING] are provided.

[ASSOCIATION] changes priority of the association of all targets while [CHANGE SELECTED TGT] changes priority of the association for selected target only.

[SETTING] designates conditional items of association among RNG, CRS, SPD, SPD LIM and TIME REPRIEVE.

RNG: It designates the range to determine association.

CRS: It designates the course to determine association.

SPD: It designates the speed difference to determine association.

SPD LIM: It designates the minimum speed to determine association.

TIME REPRIEVE: It designates the judgment time to determine association.

## Setup area

---

There are several items of setup area related to TT (ARPA) and AIS.

Common items [INPUT RNG], [AUTO ACQ AREA] and [GZ] will be explained here.

### [INPUT RNG]

(Designated in distance)

Operation ranges of TT (ARPA) and AIS.

TT (ARPA) and AIS do not function outside the range.

### [AUTO ACQ AREA]

(Designated in a fan type range)

TT: When an un-tracked target enters, it is automatically acquired and an alarm sounds.

When a tracked target enters, no alarm sounds.

AIS: When a sleeping target enters, it is changed to an active target (activated) and an alarm sounds.

When an active target enters, no alarm sounds.

### [GUARD ZONE]

(Designated in a fan type range)

TT: When a tracked target enters, an alarm sounds.

When an un-tracked target enters, no alarm sounds or it is not automatically acquired.

AIS: When an active target enters, an alarm sounds.

When a sleeping target enters, no alarm sounds.

### [FILTER]

(Designated in distance, CPA/TCPA and CLASS)

Sleeping targets are hidden.

### [AIS AUTO ACQ]

(Designated in distance and CPA/TCPA)

When a sleeping target enters, it is changed to an active target (activated) and an alarm sounds.

👉 About [FILTER RNG] and [AIS AUTO ACQ], refer to **AIS** (page3-38).

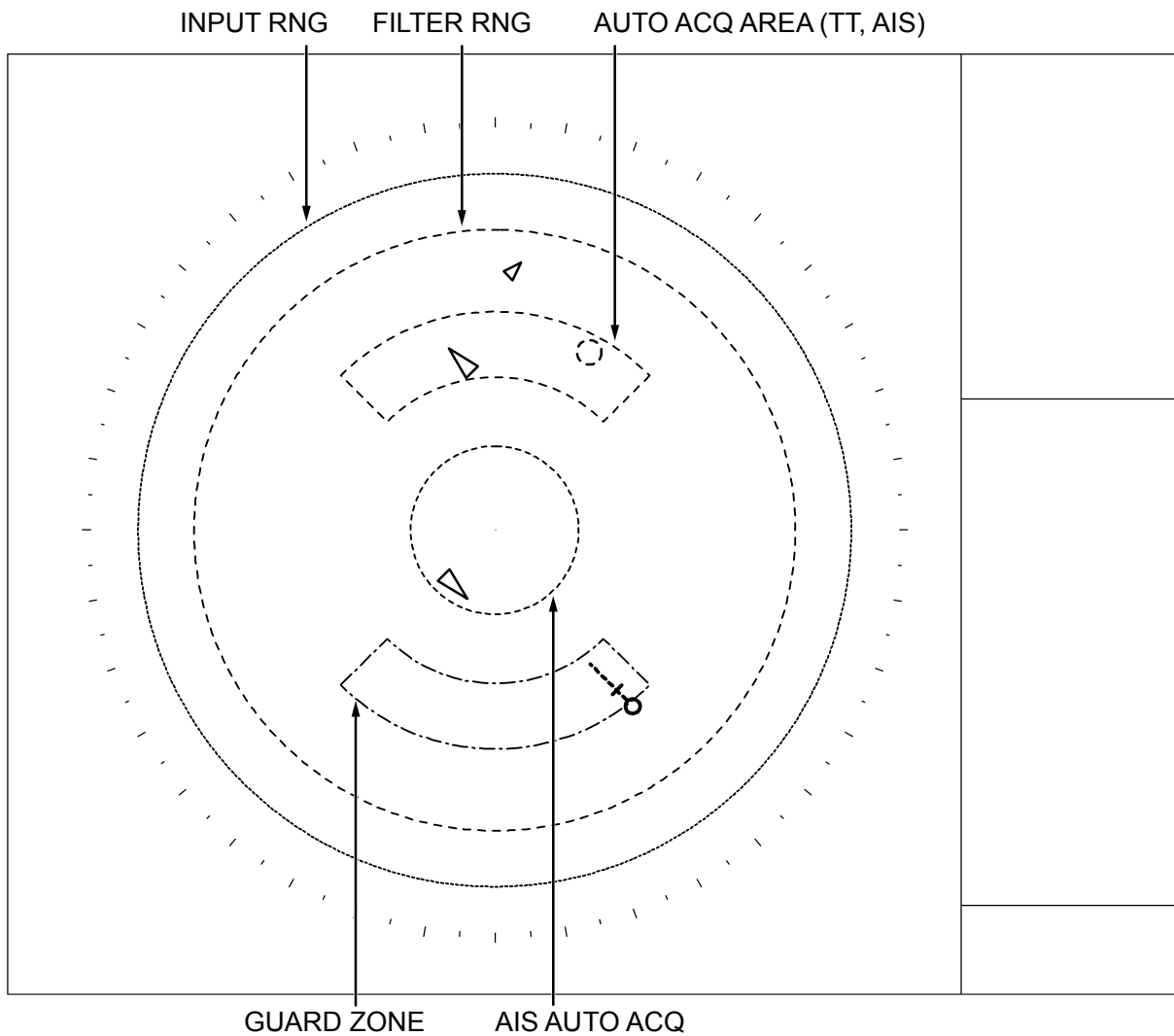

**INPUT RNG: Input range**

This is to set up the operation range of TT (ARPA) and AIS.

It designates the entire operation range of TT (ARPA) and AIS. So, TT (ARPA) and AIS do not function outside the range.

- 1 Press [MENU] key to display "Menu".  
 Select [OS/TGT] => [INPUT RNG], and then press [ENT] key after selecting the setup value.

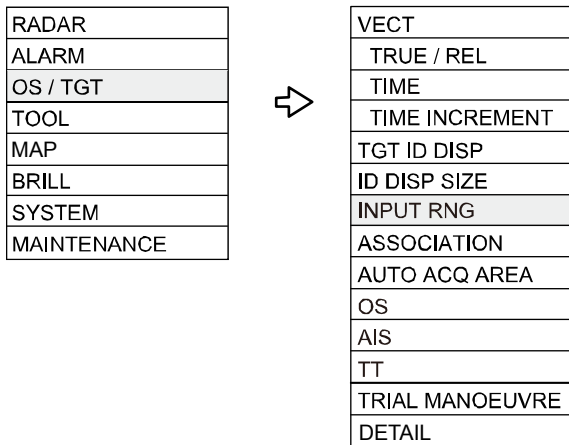



**AUTO ACQ AREA: Automatic acquisition area**

If an un-tracked TT (ARPA) target enters this area, then the automatic acquisition starts.

If an AIS sleep target enters there, then it is automatically changed into an active target.

If a TT (ARPA) tracked target or an AIS active target enters there, then no response occurs.

It takes at least 20 seconds to judge whether the target is acquirable by TT (ARPA).

Take note that the target may not be acquired when the setting area is too narrow or target is moving on high speed.

**1** Press [MENU] key to display “Menu”.

Select [OS/TGT] => [AUTO ACQ AREA], => [EDIT], and then press [ENT] key.

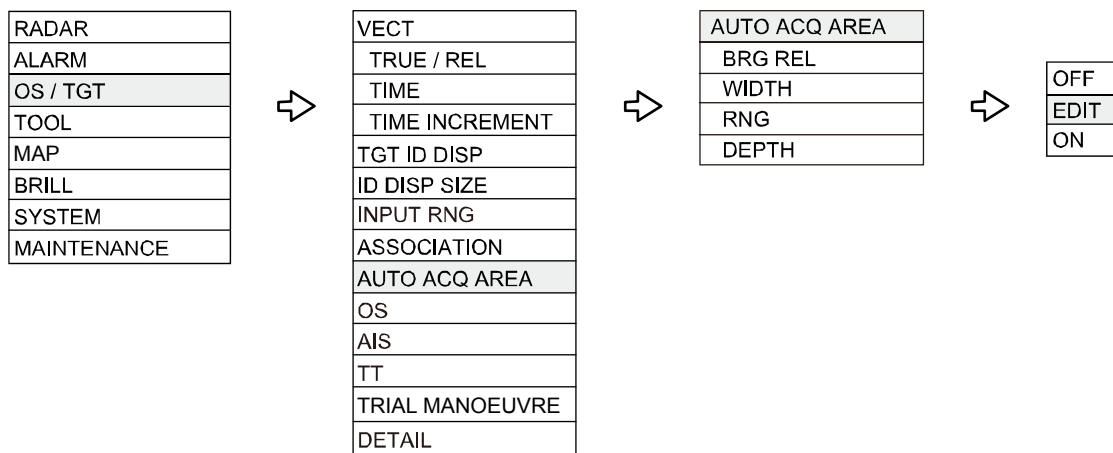

**2** Setup area.

☞ Refer to “**Echo alarm**” (page3-13) to set item and setting method.

**3** Select [AUTO ACQ AREA], => [ON], and then press [ENT] key.

## GUARD ZONE

This is used to set up a guard zone (guard from danger area).

If a TT (ARPA) tracked target or an AIS active target enters a guard zone, then a large, red symbol is displayed and [ALARM] is generated.

If a TT (ARPA) un-tracked target or an AIS sleeping target enters there, then no response occurs.

- 1 Press [MENU] key to display "Menu".

Select [ALARM] => [GZ] => [EDIT], and then press [ENT] key.

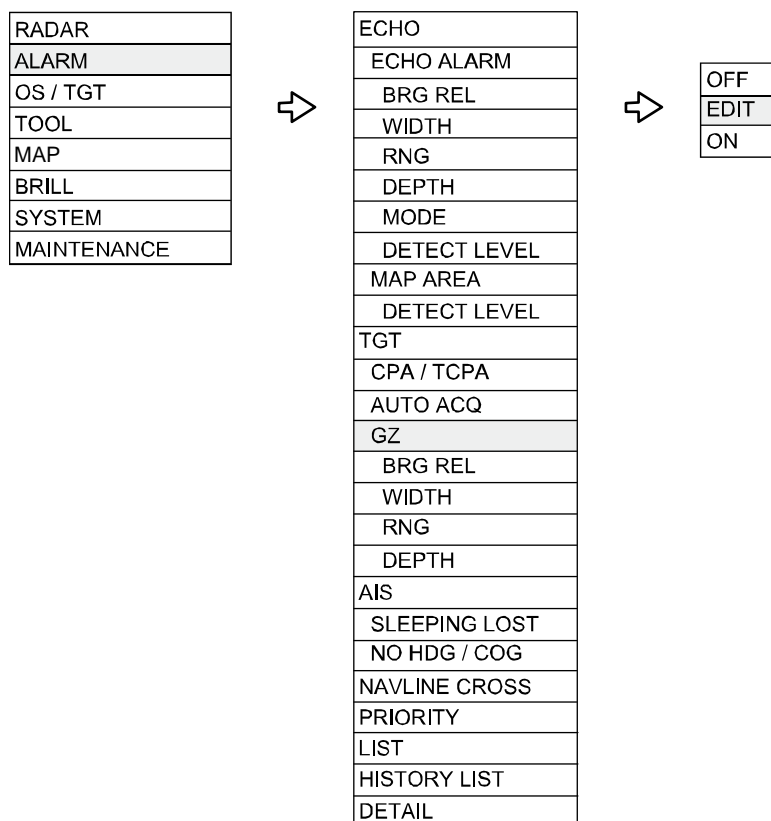

- 2 Setup area.

Refer to "Echo alarm" (page3-13) to set item and setting method.

- 3 Select [GZ] => [ON], and then press [ENT] key.

### 3.12 Target tracking TT (ARPA)

It is effective mean for collision avoidance to attach relative vectors to tracked targets.

 Refer to “**VECTOR**” (page3-15)

It is an effective means for collision avoidance to set up CPA/TCPA.

 Refer to “**CPA/TCPA**” (page3-16)

If AIS information is available with tracked targets, association increases tracking accuracy.

 Refer to “**ASSOCIATION**” (page3-18)

#### Enable TT (ARPA) function

---

There are two types of method, ON/OFF using menu or ON/OFF using [TT] in the upper right of the display screen are available.

Pressing [ACQ] key in [OFF] state makes automatically [ON] state.

\*This function does not work due to incompleteness of input sentence when own ship information display in upper right of the screen is turned red.

- 1 Press [MENU] key to display “Menu”.  
Select [OS/TGT] => [TT] => [TT] => [ON], and then press [ENT] key.

TT (ARPA) is effective by using TT in combination with [ASSISTANT DISP].

 Refer to “**ASSISTANT DISP**” (page4-39)

#### Manual acquisition

---

- 1 Move cursor using [Track ball] to lay on the target to be acquired, and then press [ACQ] key. A symbol is displayed at the cursor location, and acquisition starts.

**Delete target**

---

- 1 Use [Trackball], drag a cursor to the target to be deleted, keep [OFF] key pressed, and press [ACQ] key.

**Delete all targets**

---

- 1 Press [MENU] key to display “Menu”.  
 Select [OS/TGT] => [TT] => [ALL DELETE], and then press [ENT] key.

RADAR
ALARM
OS / TGT
TOOL
MAP
BRILL
SYSTEM
MAINTENANCE



VECT
TRUE / REL
TIME
TIME INCREMENT
TGT ID DISP
ID DISP SIZE
INPUT RNG
ASSOCIATION
AUTO ACQ AREA
OS
AIS
TT
TRIAL MANOEUVRE
DETAIL



TT
SELECT ID
ACQ
DELETE
ALL DELETE
REF ACQ
EDIT NAME
TEST TGT

## Reference target acquisition

If SDME or EPFS is not usable by breakdown or any reason, then COG/SOG can be obtained by setting Reference target.

By tracking 1 or 2 stationary targets, the true speed/the true course can be used.

This stationary tracked target is called as [Reference target].

A letter "R" denoting reference and number are attached to the lower left of Reference target symbol.

 Refer to "TGT ID" (page3-16)

- \* Reference target can be used only when COG/SOG is not available.
- \* HDG input is necessary to use a reference target.
- \* Reference target has considerable error factor caused by target size, backrush and distance. Accordingly, if COG/SOG is obtained from the reference target, then its accuracy is generally not good. It is probable to mistake a moving target for a reference target. Therefore, if a reference target is used, then CPA/TCPA of TT (ARPA), relative vector and relative speed are prohibited by IEC 62388. For this reason, if a reference target is used, its speed and vector should be only informative.
- \* Pay attention to that, if a reference target is lost, then accuracy of the true speed/the true course is significantly reduced.
- \* The combined use with AIS function cannot be performed.
- \* If the target is lost for 20 seconds, then reference target function judges as lost target. If a lost target happens, the numeral indication of COG/SOG is indicated by XXXX symbol in red. Then stabilization mode automatically changes from ground stabilization to water stabilization.

**1** Move cursor using [Track ball] to lay on the target to be acquired.

**2** Press [MENU] key to display "Menu".

Select [OS/TGT] => [TT] => [REF ACQ], and then press [ENT] key.

RADAR
ALARM
OS / TGT
TOOL
MAP
BRILL
SYSTEM
MAINTENANCE



VECT
TRUE / REL
TIME
TIME INCREMENT
TGT ID DISP
ID DISP SIZE
INPUT RNG
ASSOCIATION
AUTO ACQ AREA
OS
AIS
TT
TRIAL MANOEUVRE
DETAIL









TT
SELECT ID
ACQ
DELETE
ALL DELETE
REF ACQ
EDIT NAME
TEST TGT

**3** When reference target is tracked, [GYRO] and [REF] windows appear in the own ship information area at appear right side of the screen.

When [REF] is selected, COG/SOG computed by the reference target can be used.

## Types of tracked target symbol

The following symbols are overlapped on target.

Symbol	Symbol name
	Radar target in acquisition state
*  Blink in 0.5 sec. interval	Radar target in acquisition state - Automatic acquisition (Red color)
** 	Tracked radar target
** 	Tracked radar target (Displayed at indicating numerical value.)
**  Blink in 0.5 sec. interval	Tracked radar targets - dangerous target (Red color)
**  Blink in 0.5 sec. interval	Lost target (Red color)

\* Pressing [OFF] key to acknowledge changes target symbol to normal color and stop blinking.

\*\* ID can be displayed in Tracked target.

 Refer to "TGT ID" (page3-16) about the method to display.

\*\*\* Alarm display and alarm sound disappear by pressing [OFF] key to acknowledge, while color is remains red until the target leaves outside of setting range or tracking is stopped.

\*\*\*\* The lost target display disappears automatically when [OFF] key is pressed to acknowledge or when 10 seconds have passed.

**TEST TGT**

Two kind of test are provided.

One is check of TT (ARPA) performance and the other is check of functions.

\* For TEST TGT execution, ANT connection and input of own-ship position are required.

\*Time input (ZDA, DTM) is not necessary, but without time input, an alarm will activate periodically.

**TT (ARPA) performance check.**

Confirm that the acquisition and track of target is possible, and that the accuracy of data is within the specification mentioned below.

Time of steady state minutes	CPA NM	TCPA minutes	True course Degrees (°)	True speed
1 min: trend	1.0	–	–	–
3 min: prediction	0.3	0.5	5	0.5 kn or 1 % (whichever is greater)

● Preparation

**1** Display [Range rings] as follows:

Press [MENU] key to display “Menu”.

Select [TOOL] => [RR] => [ON], and then press [ENT] key.

☞ Refer to “**Display range rings (RR)**” (page3-11).

Range separation

Range rings

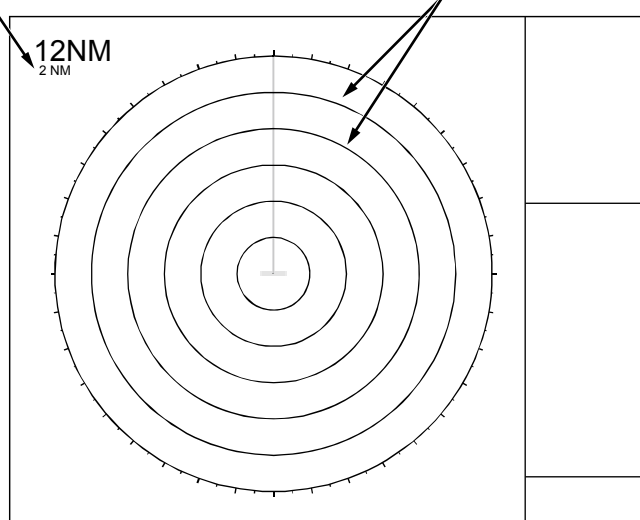

**2** Turn GAIN, RAIN and SEA knobs to maximum counter clockwise position.

- TEST TGT ON

By turning TEST TGT [ON], a large character [S] is displayed at the lower middle of the screen center.

A small character [x] is displayed in Target position.

Turn on TEST TGT, press [STBY / TX] key, and start transmission. Then, a target appears.

A target appears near the direction 10° and range 12 NM. After approaching to own ship, the target moves toward direction 170°.

Own ship's speed is about 40 kn and the target speed is about 60 kn (Relative speed is 100 kn).

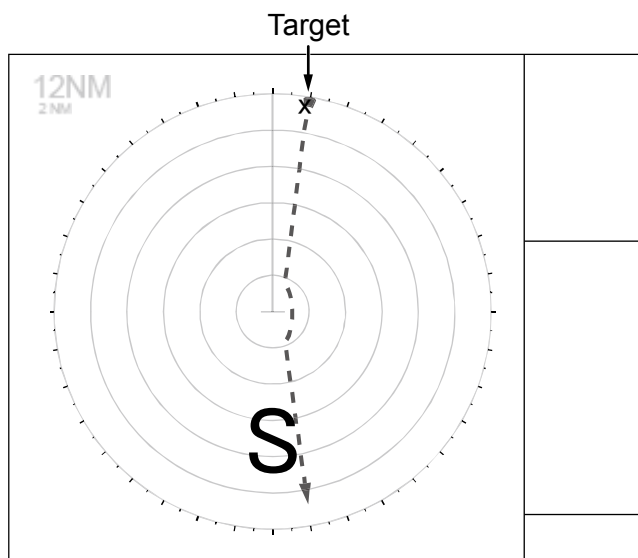

- 1 Turn ON TEST TGT.

Select [OS/TGT] => [TT] => [TEST TGT] => [ON], and then press [ENT] key.

Range is fixed at 12 NM and cannot be changed.

- 2 Press [STBY/TX] key to start transmission.



- Start ACQ

- 1 After the center of the target reaches to 10NM (the second ring from outside), use a trackball, drag a cursor to the target and press [ACQ] key.

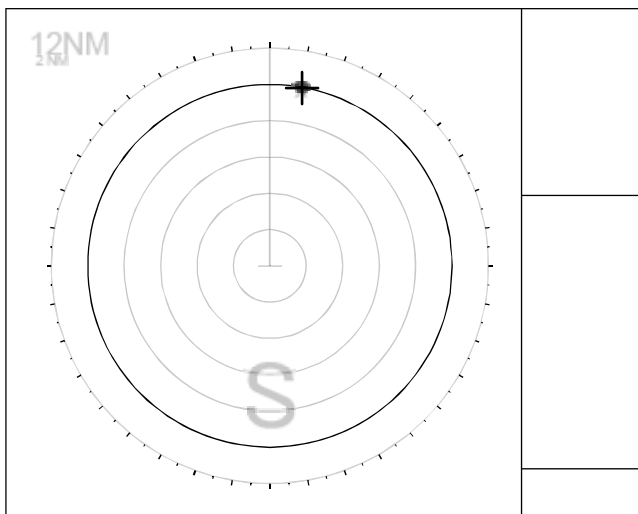

- 2 Confirm appearance of the dotted circle of acquisition start symbol and the parenthesis of value near it.

The value is indicated in [TGT INFO] area.

☞ Refer to “Types of tracked target symbol” (page3-27)

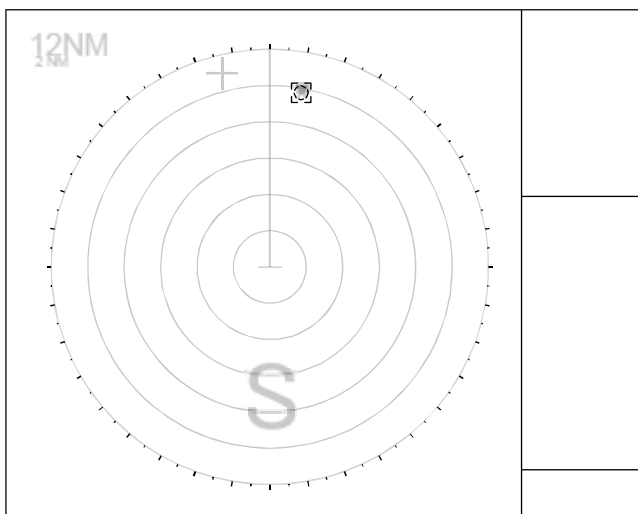

← TGT INFO area

\*If the parenthesis is not displayed, then drag a cursor to the acquisition start symbol and press [ENT] key.

- Compare it with the known result.
- 1 Tracking starts 30 seconds after the start of acquisition  
Confirm that the target has the tracking symbol.

Confirm that the symbol number is [1].

 Refer to “Types of tracked target symbol” (page3-27)

\*If the number is not correct, then no comparison with the known result is made. Delete the symbol and start it over.

- 2 Compare with the known result after 1 minute from acquisition start.

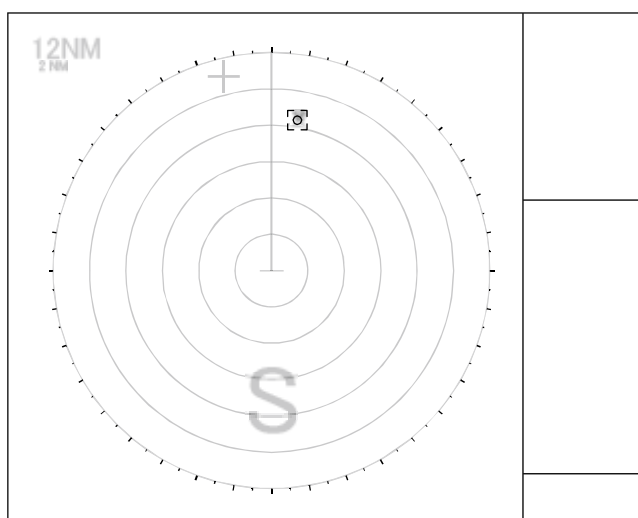

Known solution

BRG T	11.0 °
RNG	8.3 NM
CTW	199.7 °
STW	54.0 kn
CPA	0.00 NM
TCPA	5.25 Min

- 3 Compare with the known result after 3 minutes from acquisition start.

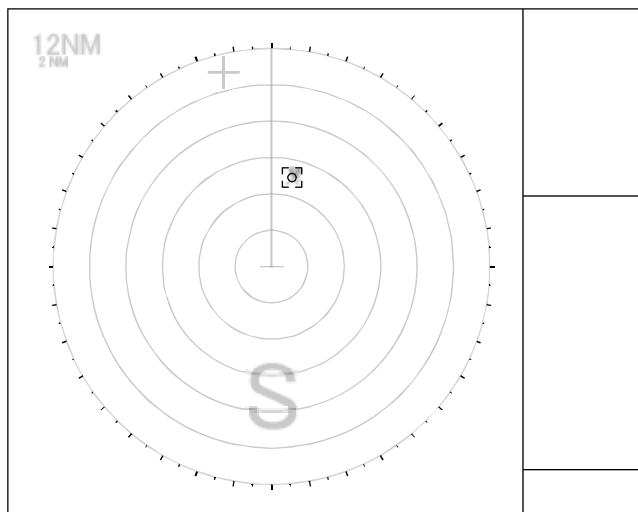

Known solution

BRG T	11.0 °
RNG	5.1 NM
CTW	199.5 °
STW	55.0 kn
CPA	0.00 NM
TCPA	3.20 Min

\*If difference from the known result exceeds the limit, then the following warning is indicated.

BRG T, RNG, T CRS, T SPD, CPA and TCPA

- TEST TGT OFF

Select [OS/TGT] => [TT] => [TEST TGT] => [OFF], and then press [ENT] key.

Stop transmission and restore GAIN, RAIN, and SEA setting value of knobs to the original value.

### Function check

This function is used to confirm the operation of Echo alarm, Manual acquisition TT (ARPA), Auto acquisition, Past position and Guard zone.

- Preparation

**1** Set up the range to 12NM.

**2** Turn GAIN, RAIN and SEA knobs to minimum.

**3** Set up the echo alarm as follows:

Press [MENU] key to display "Menu".

Select [ALARM] => [ECHO ALARM] => [EDIT], and press [ENT] key.

Set up the echo alarm range.

☞ Refer to "Echo alarm" (page3-13) to set up the range.

Select [ECHO ALARM] => [ON], and then press [ENT] key.

**4** Set up the guard zone.

Select [ALARM] => [GZ] => [EDIT], and press [ENT] key.

Set up the range of Guard zone.

[GZ] => [ON], and then press [ENT] key.

**5** Set up the Auto acquisition.

Select [OS/TGT] => [AUTO ACQ AREA] => [AUTO ACQ AREA] => [EDIT], and press [ENT] key.

Set up the range of Auto acquisition.

Select [AUTO ACQ AREA] => [ON], and press [ENT] key.

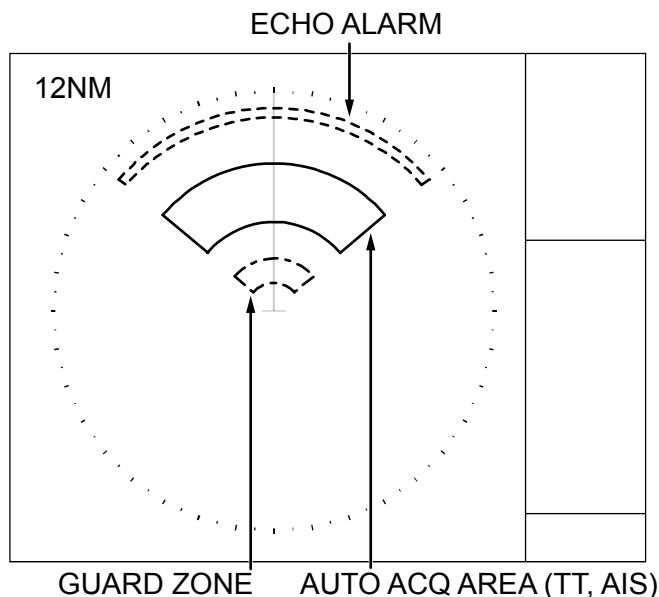

- TEST TGT ON

By turning TEST TGT [ON], a large character [S] is displayed at the lower middle of the screen center.

A small character [x] is displayed in Target position.

Turn on TEST TGT, press [STBY / TX] key, and start transmission. Then, a target appears.

Target appears near the direction 10° and range 12NM. After approaching to own ship, the target moves toward direction 170°.

Own ship speed is about 40kn and target speed is about 60kn (relative speed is 100kn).

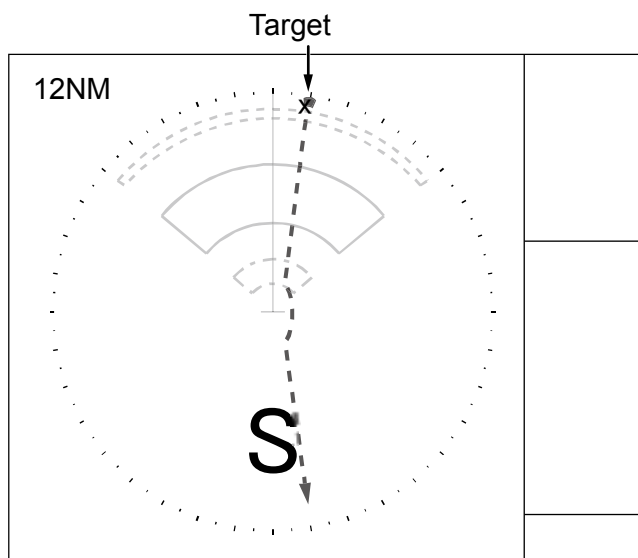

- 1 Turn on TEST TGT.  
Select [OS/TGT] => [TT] => [TEST TGT] => [ON], and then press [ENT] key.  
Range is fixed at 12 NM and cannot be changed.
- 2 Press [STBY / TX] key to start transmission.

- Echo alarm

☞ Refer to “**Echo alarm**” (page3-13)

- 1 Confirm that when the target enters the echo alarm area, the echo alarm is displayed in alarm display area at the lower right of the screen

Press [OFF] key to acknowledge. Then, alarm will disappear.

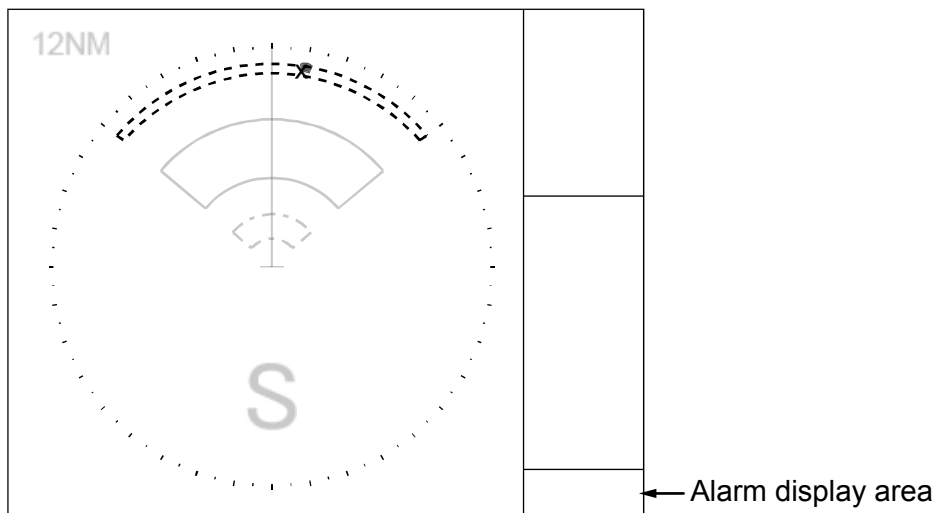

- Manual acquisition TT (ARPA)

☞ Refer to “**Target tracking TT (ARPA)**” (page3-24)

- 1 Use a trackball, drag a cursor to the target and press [ACQ] key.

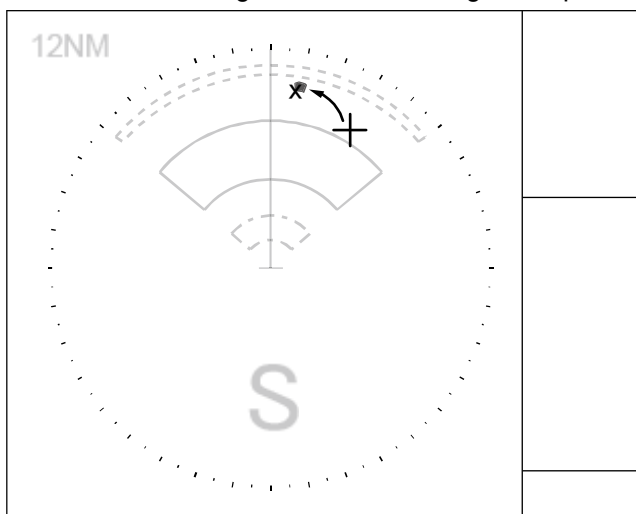

- 2 Symbol [ ] will be displayed by acquisition.

☞ Refer to “**Types of tracked target symbol**” (page3-27)

Information of symbol with [ ] is displayed in the TGT INFO area.

CPA/TCPA are displayed as [missing] until tracking is started.

Move the cursor on symbol and then press [ENT] key if [ ] is not displayed yet.

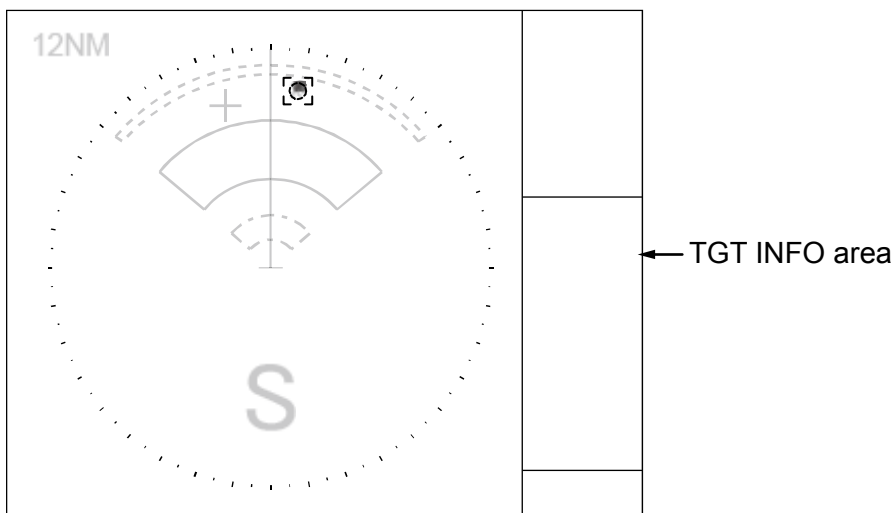

- 3 Confirm that data is changed from [missing] after the symbol is changed to tracked one.

- 4 Move the cursor again.

Delete the tracked symbol by pressing [ACQ] key while keeping [OFF] key pressed.

- Auto acquisition

☞ Refer to “**AUTO ACQ AREA: Automatic acquisition area**” (page3-22)

- 1 If a target enters the Auto acquisition area and 15 seconds pass, then automatic acquisition starts. Start of tracking is displayed in the alarm display area at lower right of the screen.

Acquired symbol is shown in blinking red until pressing [OFF] key is pressed to acknowledge.

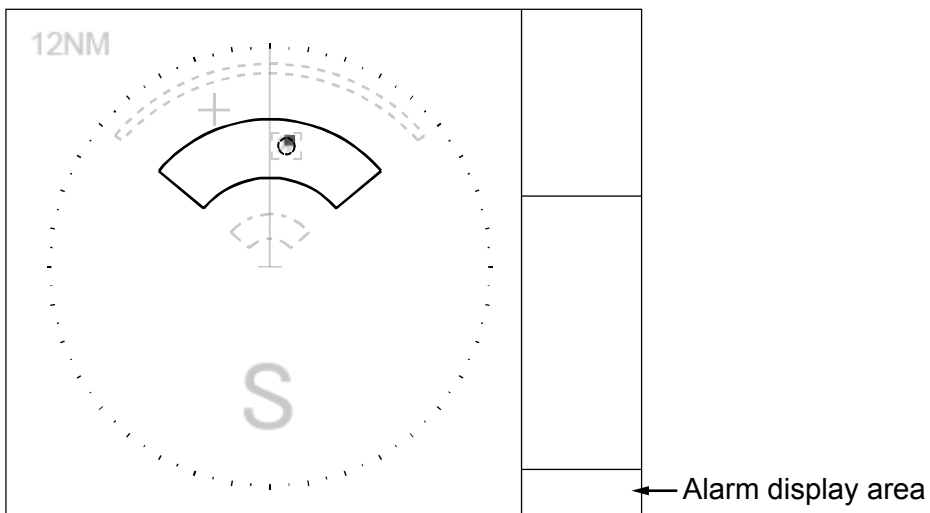

- Past position

☞ Refer to “**PAST POSN: Past position**” (page3-17)

- 1 Trail of tracked symbol is displayed by setting past position time. Set up the past position time in the “PAST POSN” at the right middle of the screen.

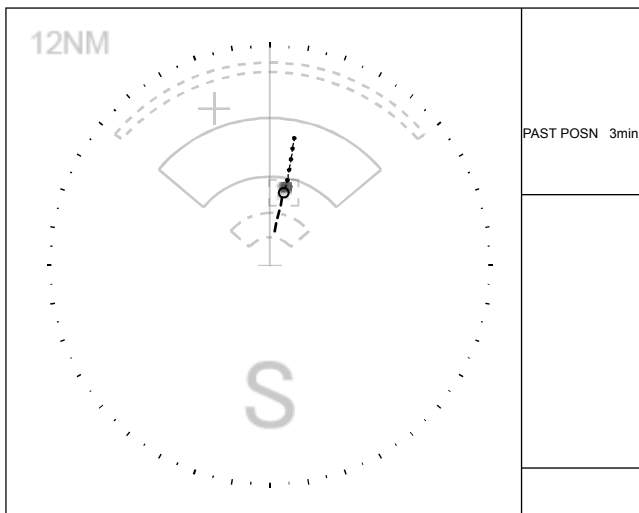

- Guard zone

☞ Refer to “**GUARD ZONE**” (page3-23)

- 1 Confirm that the Guard zone alarm is displayed in the alarm display area at the lower right of the screen when the tracked symbol has entered the Guard zone.

Blinking of tracked symbol will stop by pressing [OFF] key to acknowledge.

Tracked symbol remains red until it leaves from Guard zone.

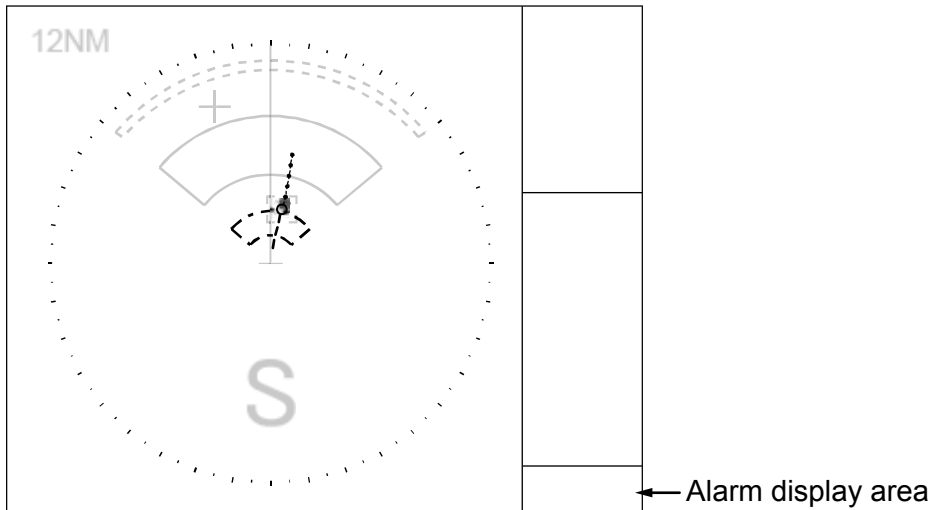

- TEST TGT OFF

Select [OS/TGT] => [TT] => [TEST TGT] => [OFF], and then press [ENT] key.

Stop transmission and restore GAIN, RAIN, and SEA setting value to original knob position.



### 3.13 AIS

- The AIS communicates with other ships via VHF (Very High Frequency) radio by transmitting your ship information and by receiving other ships information.
- Only AIS data with WGS84 datum is accepted.  
If AIS data has no datum or if datum is other than WGS84, then the warning of [AIS datum is not WGS84] appears. AIS data is not displayed.
- Capable of displaying up to 254 other ship symbols/IDs. (The 225th is own ship's AIS symbol.)
- If the displayed targets exceed 251, then the warning is displayed at the lower right of the screen. AIS target count number at the upper right of the screen changes to yellow.
- If the displayed targets exceed 254, then the alarm is displayed at the lower right of the screen. AIS target count number at upper right of the screen changes to red.  
In that case, change [INPUT RNG] value and decrease the displayed targets.

 Refer to “**INPUT RNG: Input range**” (page3-21)

\* If the displayed targets exceed 254, then next coming AIS data cannot be displayed. For the sake of safety, if warning is displayed, then change [INPUT RNG] value immediately and decrease the displayed targets.

\* If the own ship information display at upper right of the screen is turned red, then it means that the input sentence is incomplete. So, this function does not work.

If AIS is used in combination with [ASSISTANT DISP], then AIS is effective.

 Refer to “**ASSISTANT DISP**” (page4-39)

#### **Enable AIS function**

---

There are two types of method. One is [ON/OFF] using menu. The other is [ON/OFF] of [AIS] at the upper right of the screen.

- 1 Press [MENU] key to display “Menu”.  
Select [OS/TGT] => [AIS] => [AIS] => [ON], and then press [ENT] key.

#### **Setup operation area**

---

This is used to change the area where symbols are to be displayed.

The setting area is determined by radius centered from the reference point.

 Refer to “**INPUT RNG: Input range**” (page3-21)

Caution, the number of AIS symbols can not exceed 254. If the number exceeds 254, it causes a [Overflow] message on the screen and triggers an alarm sound, and the capability of AIS symbol display is lost.

## ACTIVE / SLEEP

---

[ACTIVE/SLEEP] status of target can be switched by using a trackball, dragging a cursor to the desired target and then pressing [ENT] key.

## FILTER [Sleep targets only]

---

When there are many AIS targets, the screen may become unclear. In that case, by setting filters, it is possible to hide unnecessary sleeping targets or to display the necessary targets only, and then the clear view of the target can be acquired.

\* The filter is absolutely used to limit display. When input is to be limited, [INPUT RNG] shall be operated.

 Refer to “**INPUT RNG: Input range**” (page3-21)

Only target within specified [CPA/TCPA] is displayed.

FILTER

- 1 Use a trackball and drag a cursor to [FILTER CPA/TCPA] at the upper right part of the screen.  
Press [ENT] key to get ON.

 Refer to “**CPA/TCPA**” (page3-16) to setup [CPA/TCPA].

The set items to be changed on the screen are [Range] and [Class].

RNG: It displays targets only within specified range.

\*Pay attention that the objective target may not be displayed if the setup value is too small.

CLASS: It displays targets only in setup class.

In addition, [MOORED], [AT ANCHOR], [SPD], [GZ] and [ECHO ALARM] are settable on the menu.

 Refer to “**AIS FILTER**” (page4-18) to setup [CPA/TCPA].

## AIS AUTO ACQ

---

This function automatically changes sleep target to the larger activated target (hazardous target).

It is essentially the same function as [AUTO ACQ AREA].

Even if an active target enters, no response occurs.

 Refer to “**AUTO ACQ AREA: Automatic acquisition area**” (page3-22) for [AUTO ACQ AREA].

When the sleep targets within specified CPA/TCPA value are changed to active targets:

- 1 Use a trackball and drag a cursor to [AUTO ACQ CPA/TCPA] on the upper right part of the screen.  
Press [ENT] key to get ON

 Refer to “**CPA/TCPA**” (page3-16) to setup [CPA/TCPA].

In addition, [RNG] is used to activate the targets within designated range.

### Types of AIS target symbol

The following symbols are overlapped on target.

Symbol	Symbol name
	Sleeping target
	Sleeping target without HDG.
	Sleeping target with neither reported HDG nor COG.
*	Activated target
*	Activated target without HDG.
*	Activated target with neither reported HDG nor COG.
*	Activated target - true scaled outlines
*	Activated target - dangerous targets
*	Activated target without HDG.
*	Activated target with neither reported HDG nor COG.
*	Activated target with heading lines
*	Activated target with turn indicators
	Real AIS ATON
	Virtual AIS ATON
	SART (AIS Search And Rescue Transponder)

\*ID can be displayed with Activated target.

Refer to "TGT ID (page3-16) about a method to display.

### 3.14 Trial manoeuvre

In case it is suspected the own ship could collide with tracked targets or activated AIS targets, this function provides such reference information as the actual anti-collision manoeuvre can be taken. This function is to display the simulation result in the form of graphic vector on the radar screen, on the assumption that the own ship travels with the current course and speed.

Assuming that the own ship and other ships (tracked targets and activated AIS targets) are both concurrently moving at the present course and speed [CRS·SPD] for the duration set at [DELAY], vector is displayed in such a way that the own ship is to move at the set [CRS T], [SPD], [RATE OF TURN] and [RATE OF SPD] from the starting point.

- \* Better information is provided by using relative motion and sea stabilization (water tracking).
- \* The function is terminated once the HDG input, SPD input, LAT/LON input (AIS only) are disrupted, as tracked targets and activated AIS targets are used.

**1** Press [MENU] key to display “Menu”.

Select [OS/TGT] => [TRIAL MANOEUVRE] => [GO], and then press [ENT] key.

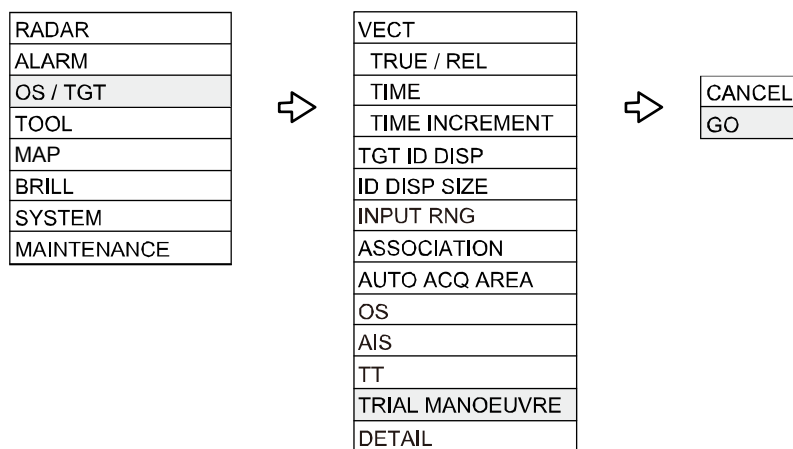

- 2 By turning TRIAL MANOEUVRE [GO], a large character [T] is displayed at the lower center of the screen and the setting menu of TRIAL MANOEUVRE is displayed at the lower right of the screen.

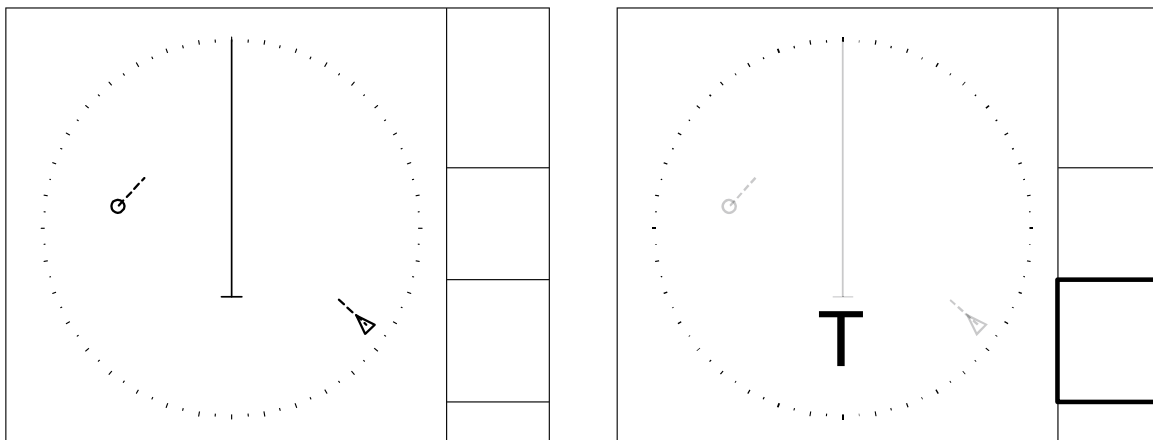

In addition, the movement of the own ship and the other ships is displayed in vector after elapse of the time set at [DELAY] of TRIAL MANOEUVRE setting menu.

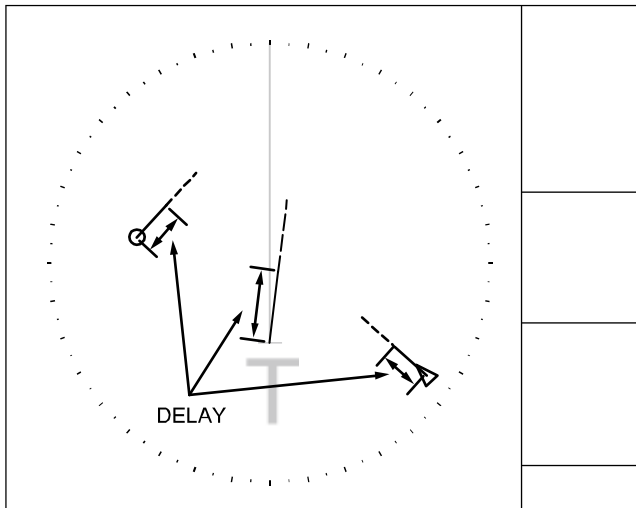

### 3 TRIAL MANOEUVRE setting menu

Each numerical value in the gray background color area is set by yourself. Move to the cursor to the gray area, press [ENT] key, a numerical value input dialogue box appears. The value of the dialog box can be set by the track ball. For [TRIAL OFF], moved the cursor [OFF] and press [ENT] key, TRIAL MANOEUVRE is finished immediately.

TRIAL MANOEUVRE		
TRIAL	OFF	300 sec
CRS T	122.4	°
SPD	10.1	kn
DELAY	3.0	min
RATE OF TURN	180.2	° / min
RATE OF SPD	10.5	kn / min

#### TRIAL: OFF

When the trial manoeuvre commences, count down starts from 300 seconds and ends at 0 second. When you desire to stop the function during the countdown, select the countdown display and set OFF.

CRS T: This indicates own ship's course after [DELAY].

SPD: This indicates own ship's speed after [DELAY].

DELAY: This indicates the starting time of TRIAL MANOEUVRE. After the time set, the own ship starts moving at [CRS T], [SPD], [RATE OF TURN], [RATE OF SPD].

RATE OF TURN: This indicates own ship's rate of turn after [DELAY].

RATE OF SPD: This indicates own ship's acceleration rate after [DELAY].

- 4 When setting is done for [CRS T], [SPD], [RATE OF TURN], [RATE OF SPD], own ship's vector will change when the vector setting is [VECT T] and the other ship's vector will change when vector setting is [VECT REL].

[TRUE VECTOR when own ship's speed is doubled]

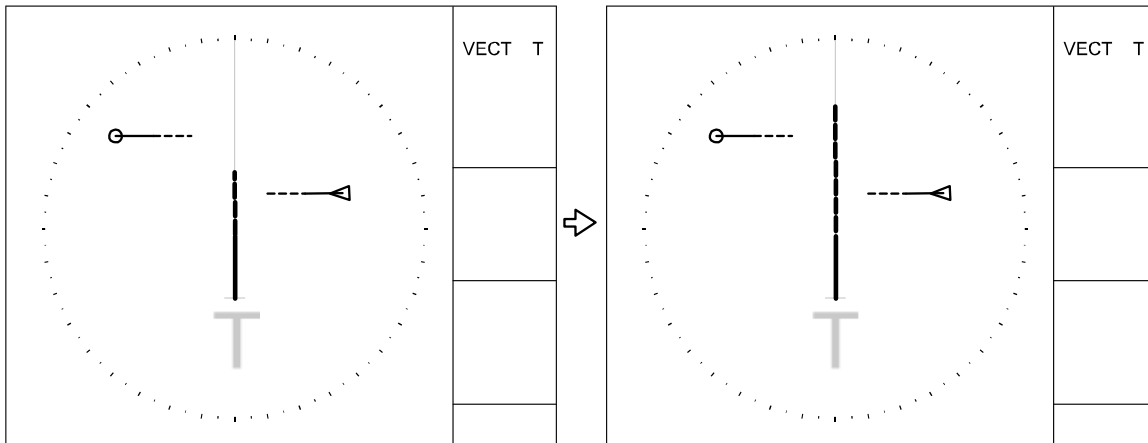

[RELATIVE VECTOR when own ship's speed is doubled]

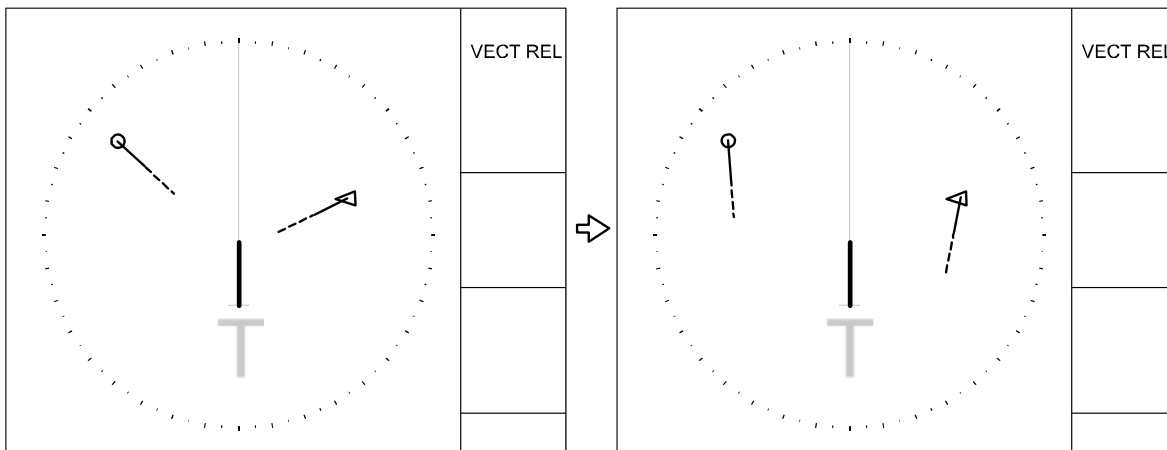

- 5 When either the [TRIAL] is set OFF or when the countdown of the [TRIAL] time becomes 0, the TRIAL MANOEUVRE is terminated.

## Chapter 4 General operation (Menu)

### 4.1 RADAR

#### TUNE MAN ADJ

---

Selection values: 0.0 to 100.0

 Refer to “**Tuning method**” (page1-1)

#### TRAIL TRUE / REL

---

Selection values: TRUE, REL

 Refer to “**Display ship’s trail**” (page3-9)

#### TRAIL TIME

---

Selection values: OFF, PERM, 1min, 3min, 6min, 12min, 24min, 48min

 Refer to “**Display ship’s trail**” (page3-9)

· [TRAIL] character at the lower left of the screen changes to yellow until recording has reached to the setup time.

#### TRAIL SHAPE

---

Selection values: CATERPILLAR, TADPOLE, FIREBALL

 Refer to “**Display ship’s trail**” (page3-9)

#### TRAIL DETECT LEVEL

---

Selection values: 1, 2, 3, 4, 5, 6

 Refer to “**Display ship’s trail**” (page3-9)

#### TRAIL RESET

---

Selection values: CANCEL, GO

 Refer to “**Display ship’s trail**” (page3-9)

#### OFF CENT POINT

---

Selection values: CURSOR, OPPOSITE

 Refer to “**Relocate antenna position (Off-centering)**” (page2-22)

#### AUTO OFF CENT

---

Selection values: OFF, ON

 Refer to “**Relocate antenna position (Off-centering)**” (page2-22)



---

## TM RESET

---

 Refer to “Reset true motion” (page2-26)

---

## C UP RESET

---

· This function resets course for C UP.

---

## DETAIL

---

---

### TM RESET MODE

---

Selection values: OPPOSITE, COURSE, CENTER

This function is to set the reset position of true motion.

 Refer to “Reset true motion” (page2-26)

It is convenient to use F key.

 Refer to “F (Function key) usage” (page2-27)

---

### HOLD

---

When this is switched on during transmission, the image is fixed without renewal.

It automatically returns to [STANDBY] after 30 seconds.

When the image is fixed, [HOLD] appears at the upper left side of the screen and blinks.

It is convenient to use F key.

 Refer to “F (Function key) usage” (page2-27)

---

### ZOOM

---

When this is switched on during transmission, an image expanded at the center of the cursor position by 1 range is displayed.

During zooming, [ZOOM] appears at the upper left of the screen.

It is convenient to use F key.

 Refer to “F (Function key) usage” (page2-27)

---

### RANGE UNIT

---

Selection values: NM, km, sm, kf

This function is to set the display unit of range on this radar.

VRM1, VRM2 and the PI can be set independently.

 Refer to “VRM1 UNIT, VRM2 UNIT, PI UNIT” (page4-22, page4-22, page4-22)

---

**ROTATION MARGIN**

---

Selection values: 0.0° to 30°

This function is to set rotation margin of images depending on the rotational angle of ship's bearing. When the ship's bearing is changing little by little, the images become stable if the set value is larger.

---

**ROTATION SPEED**

---

Selection values: 1 to 50

This function is to set the rotational speed of the images when the ship's bearing has changed.

---

**DISPLAY CENTER**

---

Selection values: ANT, CCRP

This is the function to set the center of echo screen.

---

**TRAIL RANGE KEEP**

---

Selection values: OFF, ON

OFF: When the range is changed, all trails are erased once and a new trail is displayed.

ON: When the range is changed, display of the previous trail changes gradually to the new trail while the trails before the change is kept displayed.

---

**TRAIL TIME KEEP**

---

Selection values: OFF, ON

OFF: When the trail time is changed, all trails are erased once and then a new trail is displayed. The length of trails will be displayed in the 1/6 unit.

ON: When the trail time is changed, display of the previous trail changes gradually to the new trail while the trail before the change is kept displayed. The length of the trail will be maintained constantly for the trail time.

Note: When this function is ON, drawing area alarm will become invalid.

---

**TRAIL C UP KEEP**

---

Selection values: NORMAL, CU FIX

This function is to set recording method of trails at C UP.

NORMAL: Records the trail using true bearing. Trail may sometimes stagger at the time of C UP.

C UP FIX: Records trail using the course at C UP. The trails may be deleted when the course is reset at C UP or values other than C UP have been changed.

---

**TRAIL MODE KEEP**

---

Selection values: OFF, ON

This function is to set the recording of trails in true mode or relative mode alternately.

OFF: When the trail mode is switched over between the true and the relative mode, the trail is erased

once and recorded from the start.

ON: When the trail mode is switched over between the true and relative mode, the trail is immediately displayed but roughly.

---

### TRAIL MOVE

---

Selection values: COURSE, POSITION

This function is to select COURSE or POSITION (Lat/Lon) for the display reference of trails.

If POSITION is used, the display of trails will be more stable, because there is no effect due to staggering of ship's bearing. However, latitude and longitude are to be input.

---

### TRAIL REL MODE

---

Selection values: HDG, TRUE

This function is to select either ships bearing or true direction for the recording reference of relative trails.

HDG: All trails of moving targets on the screen will be displayed.

TRUE: When the ship turns round, the trail due to the turning round will not be displayed.

---

### H UP OFFSET

---

Selection values: 0.0° to 359.9°

This function is to offset the upper part of screens from ship's bearing at H UP.

 Refer to "For H UP (Head up mode)" (page2-23).

---

### ALL PPI

---

Selection values: OFF, ON

This function is to display images and trails on all screens (excluding menu area and own ship's information area).

---

### ECHO MOVE

---

Selection values: SCAN, SWEEP

This is to set a timing of rewrite of echo.

---

### FERRY MODE

---

Selection values: OFF, 1, 2

It is a function to use a river for by coming and going ferry etc.

It becomes effective at H UP, and the letter of the FERRY appears on the left of the screen while using it.

1. The display image reverses, and the heading marker turns to the bottom.
2. The heading marker direction indication reverses by 180 degrees as well as above 1.

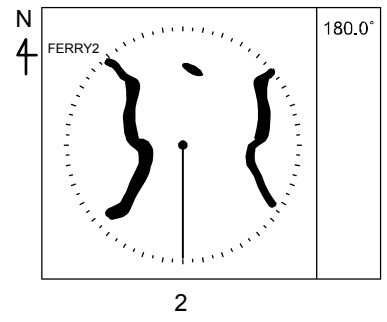
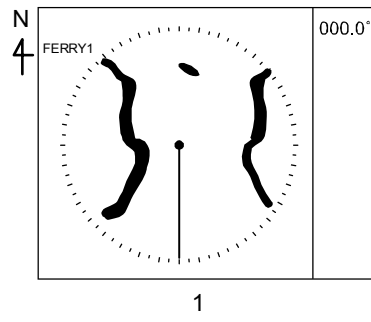
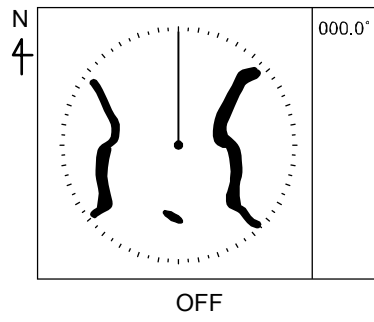

## 4.2 ALARM

### ECHO ALARM

---

Selection values: OFF, EDIT, ON

 Refer to “**Echo alarm**” (page3-13)

### ECHO ALARM MODE

---

Selection values: IN, OUT

 Refer to “**Echo alarm**” (page3-13)

### ECHO ALARM DETECT LEVEL

---

Selection values: 1, 2, 3, 4, 5, 6, 7

 Refer to “**Echo alarm**” (page3-13)

### MAP AREA

---

Selection values: OFF, IN, OUT

· This function provides alarm display when ECHO enters to or leaves from the MAP AREA.

### MAP AREA DETECT LEVEL

---

Selection values: 1, 2, 3, 4, 5, 6, 7

· This function is to set up detection level of the above alarm.

### CPA / TCPA

---

Selection values: OFF, ON

· This function provides alarm display when the values become lower than setup CPA/TCPA.

 Refer to “**CPA/TCPA**” (page3-16)

### AUTO ACQ

---

Selection values: OFF, ON

 Refer to “**AUTO ACQ AREA: Automatic acquisition area**” (page3-22)

### GZ

---

Selection values: OFF, EDIT, ON

 Refer to “**GUARD ZONE**” (page3-23)

### AIS SLEEPING LOST

---

Selection values: OFF, ON

· This function provides alarm display when sleeping target is lost.

## **AIS NO HDG / COG**

---

Selection values: OFF, ON

· This function provides alarm display when HDG or COG information of an active target is not included in the received signal.

 Refer to “**Types of AIS target symbol**” (page3-40)

## **NAVLINE CROSS**

---

Selection values: OFF, ON

· This function provides alarm display when own ship reaches (intersects with) to nav-line.

 Refer to “**NAV LINE**” (page4-26)

## **PRIORITY**

---

Selection values: NONE, RADAR, AIS, NAV, EPFS, SDME, GYRO

This function is to give priority to alarm display when two or more alarms occur at the same time.

Alarm with priority is displayed by first priority and then other alarms are displayed as occurs

When an alarm with priority occurs, it replaces the alarm displayed.

NONE: No priority is applied. Alarm is displayed as occurs.

RADAR: Priority is given to alarm within the system.

AIS: Priority is given to ALR sentence from external equipment at AIS connector.

NAV: Priority is given to ALR sentence from external equipment at NAV connector.

EPFS: Priority is given to ALR sentence from external equipment at EPFS connector.

SDME: Priority is given to ALR sentence from external equipment at SDME connector.

GYRO: Priority is given to ALR sentence from external equipment at GYRO connector.

 Refer to “**About alarms**” (page7-9) about alarm.

### LIST

It displays a list of past alarms.

It lists the alarms activated by the error device selected by the above-mentioned [PRIORITY] in chronological order from top to bottom. Then, it lists the alarms of other error devices in the same order.

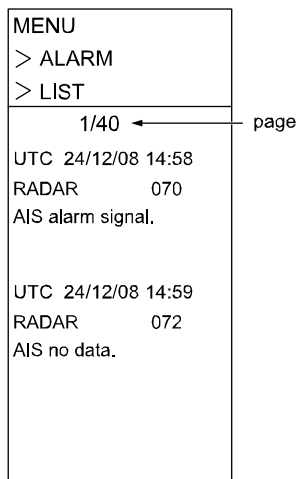

Up and down roll action of the track ball turns pages.

Alarm goes off automatically when cause of alarm disappears.

### HISTORY LIST

It lists the history of past alarms.

It lists the alarms activated in the past in chronological order from top to bottom.

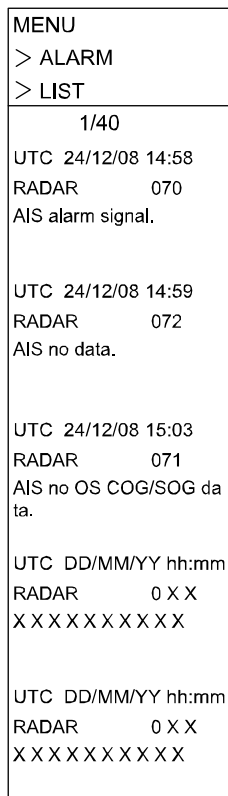

Maximum number of alarms which can be displayed is 200. Alarms in excess of 200 are deleted.

The up and down roll action of the track ball turns pages.

## DETAIL

---

### AIS MESSAGE

---

Selection values: OFF, ON

At AIS, it is possible to send and receive private messages.

This function is to set audible sound at the time of receiving a message to own ship.

To use this function, it is necessary to input the own ship's MMSI number.

 Refer to "**OS MMSI**" (page4-19)

When a message is received, the AIS target that sent the message is selected.

(A mark  is affixed to the target symbol.)

When ASSISTANT DISP is set at [AIS INFO], the received message can be confirmed.

 Refer to "**ASSISTANT DISP**" (page4-39)



## 4.3 OS / TGT

### VECT TRUE/REL

---

Selection values: TRUE, REL

 Refer to “**VECTOR**” (page3-15)

### VECT TIME

---

Selection values: OFF, 30sec, 1min, 3min, 6min, 12min, 30min, 60min

 Refer to “**VECTOR**” (page3-15)

### VECT TIME INCREMENT

---

Selection values: OFF, 2, 3, 5, 10

 Refer to “**VECTOR**” (page3-15)

### TGT ID DISP

---

Selection values: OFF, NUMBER, LABEL, BOTH

 Refer to “**TGT ID**” (page3-16)

### ID DISP SIZE

---

Selection values: X-SMALL, SMALL, MIDDLE, LARGE

 Refer to “**TGT ID**” (page3-16)

### INPUT RNG

---

Selection values: 1.0NM to 64.0NM

 Refer to “**INPUT RNG: Input range**” (page3-21)

### ASSOCIATION

---

Selection values: OFF, TT, AIS

 Refer to “**ASSOCIATION**” (page3-18)

### CHANGE SELECTED TGT

---

 Refer to “**ASSOCIATION**” (page3-18)

### SETTING

---

 Refer to “**ASSOCIATION**” (page3-18)

### AUTO ACQ AREA

---

Selection values: OFF, EDIT, ON

 Refer to “**AUTO ACQ AREA: Automatic acquisition area**” (page3-22)

## STAB INDICATOR

Selection values: OFF, ON

· This function is to display the mark of GND or SEA in STAB at the front edge of own ship vector.

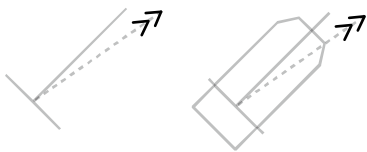
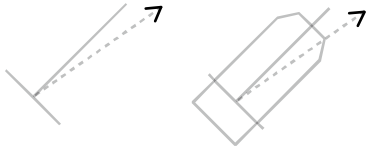
Symbol	Symbol name
	GND indicator
	SEA indicator

\*This is displayed only when VECTOR is displayed.

☞ Refer to “**VECTOR**” (page3-15)

## ANT POSN

Selection values: OFF, ON

· This function is to display the mark indicating the antenna position of own ship.

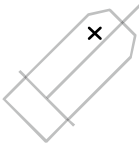
Symbol	Symbol name
	ANT position

☞ Refer to “**Setup own ship profile**” (page1-5) for the setup of antenna position.

\*This displays only when the display of “SHIP OUTLINE” is turned “ON”.

☞ Refer to “**SHIP OUTLINE**” (page4-14)

\*It is displayed only during transmission.

**PAST TRK TIME**

Selection values: OFF, 30sec, 1min, 3min, 6min, 12min, 30min, 60min

· Select the length of own ship past track with time.

\*[OS PAST TRK TIME] can be changed directly at the lower left side of the screen, with trackball and [ENT] key, without using menu function.

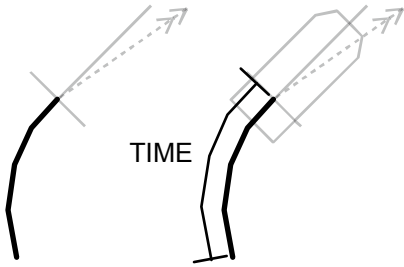
Symbol	Symbol name
	<p>Own ship past track</p>

\* The PAST TRK by its nature records and displays past location. So, it does not display an image just after being transmitted.

In addition, after the change of [TIME], recording is repeated. So, the trail is not displayed immediately. Until recording has reached to the setup time, [OS PAST TRK] characters at the lower left side of the screen change to yellow.

### PAST TRK TIME INCREMENT

Selection values: OFF, ON

[PAST TRK TIME INCREMENT] shows the short lines that are drawn perpendicularly to the own ship track in the total length of own ship track. The position of drawing is where [VECT TIME] length is divided by [VECT TIME INCREMENT].

☞ Refer to “**VECTOR**” (page3-15)

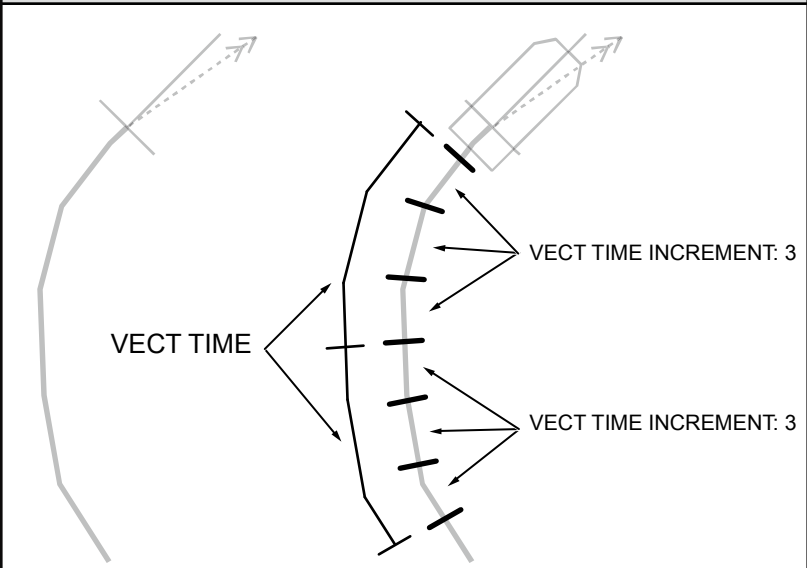
Symbol	Symbol name
	<p>Own ship past track time increment</p>

### PAST TRK RESET

·This is to delete recorded trail and then restart recording.

### STERN LINE

Selection values: OFF, ON

·This is to set up the display of dotted line extended from reference point to bearing scale toward stern direction.

☞ Refer to “**Setup own ship profile**” (page1-5) to set up the reference point.

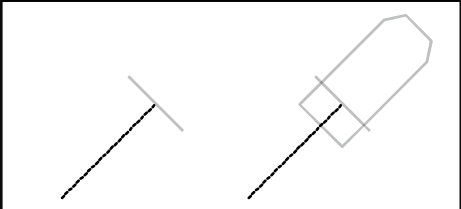
Symbol	Symbol name
	<p>STERN LINE</p>

## SHIP OUTLINE

---

Selection values: OFF, ON

 Refer to **"Setup own ship profile"** (page1-5) for set up of SHIP OUTLINE.

When the ship's width is 10m or less at the "Setup own ship profile", even 0.125NM does not show the own ship profile.

## AIS

---

Selection values: OFF, ON

 Refer to **"AIS"** (page3-38)

## SELECT ID

---

Selection values: 100 to 355

· This is to change the target selected in this item by using [AIS ACTIVE/SLEEP] function.

 Refer to **"TGT ID"** (page3-16)

## ACTIVE / SLEEP

---

· This is to change ACTIVE/SLEEP of the target selected by [AIS SELECT ID] function.

\*The change of ACTIVE/SLEEP can be executed also by pointing target with cursor in addition to designate number.

 Refer to **"ACTIVE / SLEEP"** (page3-39)

## LABEL

---

Selection values: NAME, MMSI, IMO, CALLSIGN

 Refer to **"TGT ID"** (page3-16)

## SHIP OUTLINE

---

Selection values: OFF, ON

\* This is displayed only when OUTLINE is included in the target information received by AIS.

 Refer to **"Types of AIS target symbol"** (page3-40)

## HDG LINE

---

Selection values: OFF, ON

\* This is displayed only when HDG LINE is included in the target information received by AIS.

 Refer to **"Types of AIS target symbol"** (page3-40)

## TURN INDICATOR

---

Selection values: OFF, ON

\* This is displayed only when HDG LINE is included in the target information received by AIS.

 Refer to **"Types of AIS target symbol"** (page3-40)

**CLASS B**

Selection values: OFF, ON

This function is to turn ON/OFF the receiving AIS CLASS B ship data.

It is used when the display of CLASS A ship is not available due to presence of too many CLASS B ships.

**ATON**

Selection values: OFF, ON

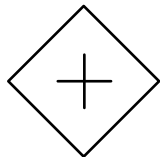
Symbol	Symbol name
	ATON: Aids to navigation

**SAR (Search and rescue aircraft)**

Selection values: OFF, ON

**BASE**

Selection values: OFF, ON

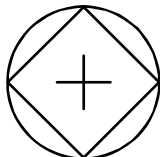
Symbol	Symbol name
	BASE

**OS DISP**

Selection values: OFF, ON

This is to set up display of own ship AIS symbol.

**MESSAGE DISP**

Selection values: OFF, LOW, MIDDLE, HIGH

This is to set up display speed when message is included in AIS information.

Message is display at "AIS INFO" of ASSISTANT DISP.

 Refer to "ASSISTANT DISP" (page4-39)

## TT

---

Selection values: OFF, ON

 Refer to “**Target tracking TT (ARPA)**” (page3-24)

## SELECT ID

---

Selection values: 1 to 60

· This is to delete target selected by [TT DELETE] function.

 Refer to “**TGT ID**” (page3-16)

## ACQ

---

 Refer to “**Target tracking TT (ARPA)**” (page3-24)

## DELETE

---

· This is to delete target selected by [TT SELECT ID] function.

· TT (ARPA) deletion can be executed also by pointing a cursor in addition to designation of the corresponding number.

 Refer to “**Target tracking TT (ARPA)**” (page3-24)

## ALL DELETE

---

 Refer to “**Target tracking TT (ARPA)**” (page3-24)

## REF ACQ

---

 Refer to “**Reference target acquisition**” (page3-26)

## EDIT NAME

---

This is to edit label of target selected by [TT SELECT ID] function.

Up to 10 characters available to input.

 Refer to “**TGT ID**” (page3-16)

## TEST TGT

---

Selection values: OFF, ON

· This function is used to confirm direction for use of Echo alarm, Manual acquisition TT (ARPA), Auto acquisition, Past position and Guard zone.

 Refer to “**TEST TGT**” (page3-28)

**TRIAL MANOEUVRE**

Selection values: CANCEL, GO

☞ Refer to “Trial manoeuvre” (page3-41)

**DETAIL**

**PAST TRK SETUP**

Selection values: OFF, DISP, OS, TT, AIS

This function is to set up recording of own ship’s trail, TT (ARPA) or AIS, non recording of them (OFF) or displaying of the recorded trails (DISPLAY) for each record No.

Structure of set up menu:

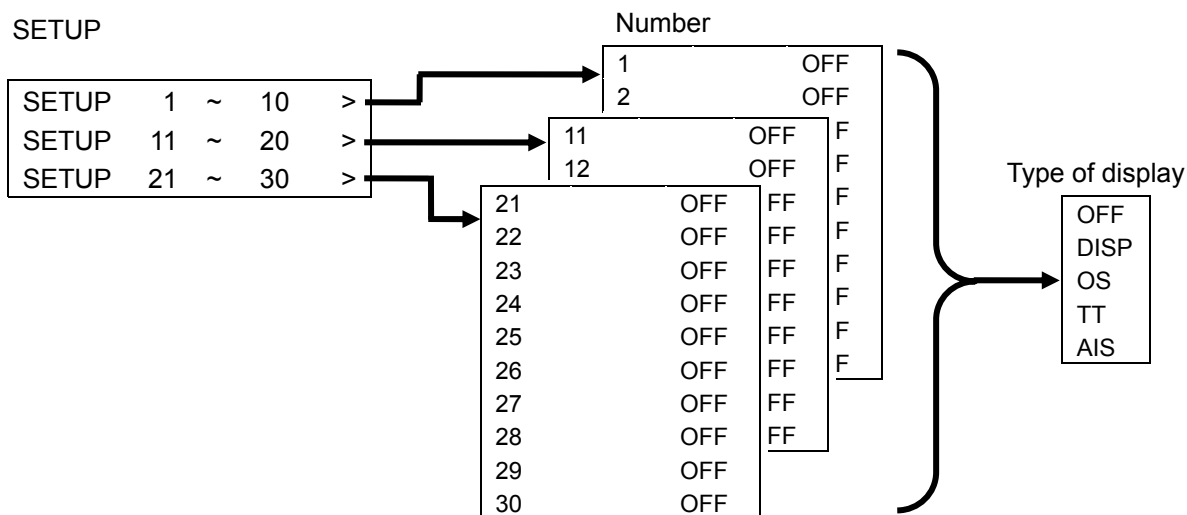

**PAST TRK PLOT INT**

Selection values: OFF, PERM, 15sec, 30sec, 1min, 3min, 6min, 12min

This is to set up recording intervals of line trails. The recoding capacity of one record No. is 1000 points. Therefore, when the recording interval is set short, the trail line will become smooth, but the maximum recording time will become shorter. The relation between the recording intervals and the maximum recording times will be as shown in the below table:

Recording interval	Maximum recording time
PERM	Approx. 30 min.
15 sec	Approx. 4 hours
30 sec	Approx. 8 hours
1 min	Approx. 16 hours
3 min	Approx. 50 hours
6 min	Approx. 100 hours
12 min	Approx. 200 hours



### PAST TRK CLEAR

Selection values: CANCEL, GO

When a new trail is to be recorded on a used recording No., assign the recording No. and delete the trail recoded on the recoding No.

Structure of the delete menu:

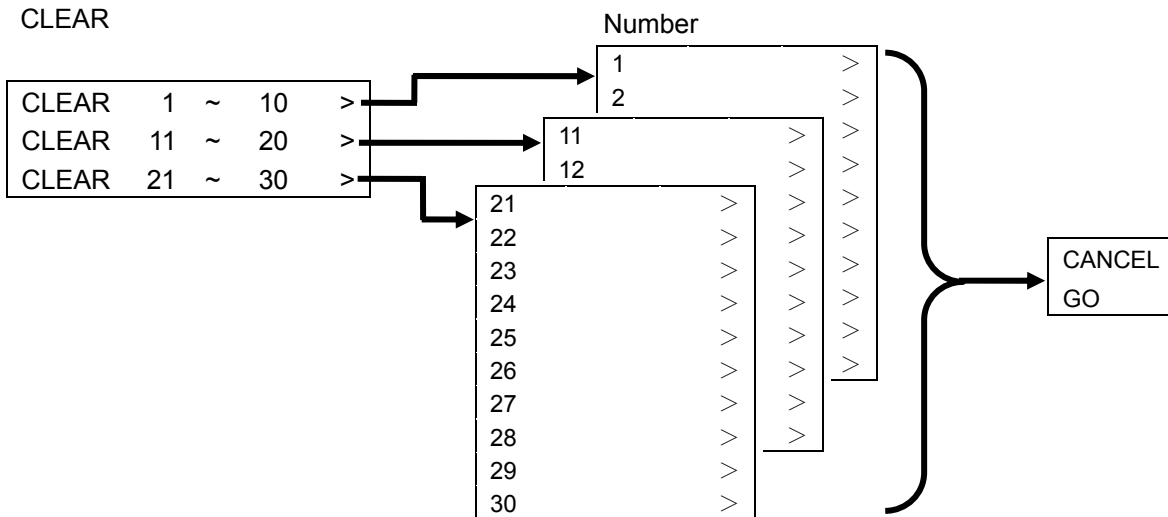

### PATH PREDICTOR

Selection values: OFF, ON

This function is to set display of the own ship's predicted course.

If this is switched on, own ship's vector is changed to the display of predicted course.

### BCR/BCT DISP

Selection values: OFF, ON

This is the function to display BCR/BCT information of the target presently selected out of tracking targets or AIS targets.

The information of the selected target is displayed in the target information area at the center right side of the screen.

BCR: When the selected target crosses own ship's course, the distance between the crossing point and own ship is displayed.

BCT: When the selected target crosses the own ship's course, the time between the present and the time of crossing is displayed.

### AIS FILTER MOORED

Selection values: OFF, ON

This function is to set hidden display for sleeping targets on the berth.

---

**AIS FILTER AT ANCHOR**

---

Selection values: OFF, ON

This function is to set hidden display for sleeping targets at anchor.

---

**AIS FILTER SPD**

---

Selection values: 0.0 to 100.0kn

This is to set hidden display for sleeping targets that are at speed less than a set value.

---

**AIS FILTER GZ**

---

Selection values: OFF, ON

This function is to set display of sleeping targets when they are within the guard zone even they are outside of [FILTER RNG].

---

**AIS FILTER ECHO ALARM**

---

Selection values: OFF, ON

This function is to set display of sleeping targets when they are within the Echo Alarm even they are outside of [FILTER RNG].

---

**OS MMSI**

---

Selection values: 0 to 1073741824

This is for inputting of the MMSI number of AIS transmitter/receiver on own ship.

At AIS, it is possible to communicate with the specified other parties.

With inputting the MMSI number, messages to own ship can be distinguished.

It is possible to sound an alarm when a message to own ship is received.

 Refer to “**AIS MESSAGE**” (page4-9)

---

**HL BLINK**

---

Selection values: OFF, ON

This is to set blinking of the head line.

With blinking of head line that is always displayed, the targets overlapped on the head line can be seen easily.

---

**TRIAL MANOEUVRE**

---

This is the function for trial maneuver of own ship.

## 4.4 TOOL

### RR

---

Selection values: OFF, ON

 Refer to “**Display range rings (RR)**” (page3-11)

### BRG TRUE/REL

---

Selection values: TRUE, REL

 Refer to “**Bearing mode set up**” (page3-12)

### CURSOR SHAPE

---

Selection values:  $\uparrow$ ,  $\downarrow$ ,  $\leftarrow$ ,  $\rightarrow$ ,  $\swarrow$ ,  $\searrow$

·This is to set up shape of cursor.

### PI LINE

---

Selection values: 1, 2, 3, 4, 5, 6, 7

This is to set up line No. for setting the following [PI LINE DISP], [PI LINE START RNG] and [PI LINE END RNG].

 Refer to “**Measure distance/bearing (PI: Parallel index line)**” (page2-17)

### PI LINE DISP

---

Selection values: OFF, ON

This is to select display or non-display of line No. selected with [PI LINE].

 Refer to “**Measure distance/bearing (PI: Parallel index line)**” (page2-17)

### PI LINE START RNG

---

Selection values: -96.0NM to 96NM

This is to set up the length from the center of the line of the line No. selected with [PI LINE].

 Refer to “**Measure distance/bearing (PI: Parallel index line)**” (page2-17)

### PI LINE END RNG

---

Selection values: -96.0NM to 96NM

This is to set up the length on the other side from the starting distance of the line No. selected with [PI LINE].

 Refer to “**Measure distance/bearing (PI: Parallel index line)**” (page2-17)

### PI DISP SIDE

---

Selection values: FULL, HALF

This is to set up whether the line is to be drawn at one side or the both sides of the reference point.

 Refer to “**Measure distance/bearing (PI: Parallel index line)**” (page2-17)

### **EBL1 OFFSET**

---

Selection values: RM, TM

· This is to set up display mode of EBL1 OFFSET.

RM: The center of rotation of EBL OFFSET will be fixed on the radar screen.

TM: The center of rotation of EBL OFFSET will move together with own ship. This is effective to measure the distance between fixed targets away from the reference point.

### **EBL2 OFFSET**

---

Selection values: RM, TM

· This is to set up display mode of EBL2 OFFSET.

RM: The center of rotation of EBL OFFSET will be fixed on the radar screen.

TM: The center of rotation of EBL OFFSET will move together with own ship. This is effective to measure the distance between fixed targets distant from the reference point.

## DETAIL

---

### PI MODE

---

Selection values: CURSOR, LINE

This is to select an operation mode of the PI.

CURSOR: This is the mode for simultaneously operating of lines in parallel.

Distance between lines and their bearing cannot be changed independently.

The length of the lines cannot be changed.

LINE:  Refer to “**Measure distance/bearing (PI: Parallel index line)**” (page2-17)

### PI CURSOR

---

Selection values: NORMAL, 1, 2, 3, 4, 5, 6, 7

This is to select the number of display lines when parallel cursor mode is set in [CURSOR].

At NORMAL, only the number of range rings is displayed (The number of range rings depends on the ranges used.)

### VRM1 UNIT

---

Selection values: NM, km, sm, kf, RANGE LINK

This is to set the display unit for range for VRM1.

The unit of range for other than VRM1, VRM2 and PI can be also set in [Range unit].

 Refer to “**RANGE UNIT**” (page4-2)

### VRM2 UNIT

---

Selection values: NM, km, sm, kf, RANGE LINK

This is to set the display unit for range for VRM2.

The unit of range for other than VRM1, VRM2 and PI can be also set in [Range unit].

 Refer to “**RANGE UNIT**” (page4-2)

### PI UNIT

---

Selection values: NM, km, sm, kf, RANGE LINK

This is to set the display unit for range for PI.

The unit of range for other than VRM1, VRM2 and PI can be also set in [Range unit].

 Refer to “**RANGE UNIT**” (page4-2)

---

**CURSOR**

---

Selection values: OFF, ON, LAT/LON

This is to set display method of cursor.

OFF: When the cursor has not been used for 30 seconds, it is hidden. It appears when operated.

ON: Cursor is always displayed.

LAT/LON: Those are always displayed. The latitude and longitude of the cursor position are displayed at the lower right side of the screen.

\* It is necessary to input latitude and longitude.

---

**CURSOR HUP MOVE**

---

Selection values: OFF, ON

This is to set tracking of the cursor position that responds to head bearing at H UP.

Even when head bearing varies frequently, it would become easy to overlap the cursor on targets.

---

**VRM/EBL CROSS**

---

Selection values: OFF, ON

This is to display a circle at the intersecting points of VRM1 and EBL1, and VRM2 and EBL2, respectively.

---

**SCALE**

---

Selection values: OFF, ON

This is to set display or non-display of the bearing scale.

---

**SCALE CHARA**

---

Selection values: OFF, ON

This is to set display or non-display of the bearing angle outside of the bearing scale.

---

**SCALE CHARA TYPE**

---

Selection values: NUMERIC, SYMBOL

This is to set display type of bearing angle.

---

**GUARD LINE**

---

Selection values: OFF, ON

This is to set display or non-display of parallel lines on the right and left sides of own ship.

---

**GUARD LINE LEFT**

---

Selection values: 0 to 10000m

This is to set the distance from own ship to the guard line on the left side of own ship.

**GUARD LINE RIGHT**

---

Selection values: 0 to 10000m

This is to set the distance from own ship to the guard line on the right side of own ship.

**EBL TRUE MODE**

---

Selection values: OFF, ON

This is to set the display method of true EBL.

OFF: The true EBL on the screen is fixed and the displayed numerical figure will vary according to the rotation of the bearing.

ON: The true EBL on the screen will rotate according to the rotation of bearing and the displayed numerical figure will be fixed.

**ERBL**

---

Selection values: LINE, RING

This is to select the shape of a marker on ERBL.

LINE

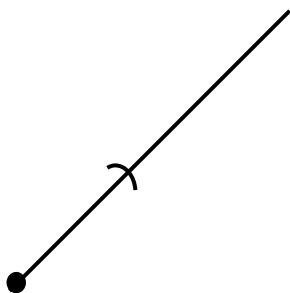

RING

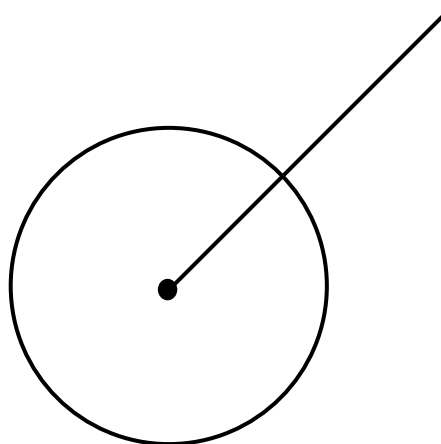

## 4.5 MAP

### DISP

Selection values: OFF, ON

- This is to set up display or non display of the entire MAP functions.
- [MAP DISP] can be changed directly at the lower left of the screen, with trackball and [ENT] key, without using menu function.

\*It is not displayed as well as HL while [OFF] key is pressed.

☞ Refer to “**Remove the heading line**” (page2-21).

### DISP GROUP

Selection values: 1 to 20

- This is to designate display group out of 20 groups.
- It is convenient to record separately such as by region.
- One group consists of [COAST LINE], [NAV LINE], [ROUTE], [EVENT MARK] and [AREA] and there are 20 blocks, respectively. You can set up the display or non-display by setting from the following items.

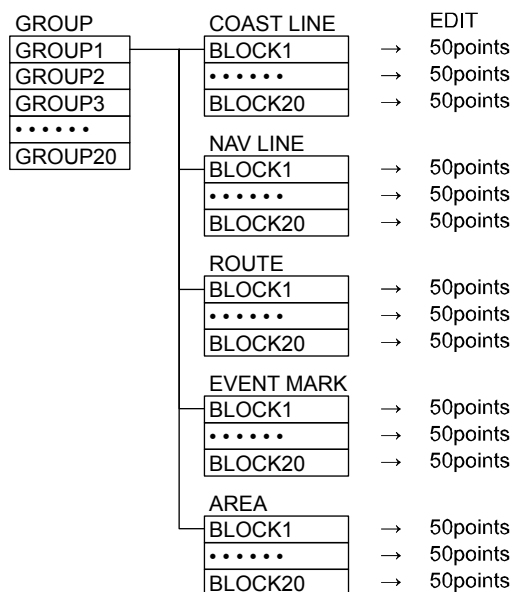

### DISP GROUP COAST LINE

Selection values: OFF, 1 to 20, ALL

- This is the function to select blocks of coast line to be displayed.
- This is to designate block to be displayed out of 20 blocks.

☞ Refer to “**EDIT COAST LINE**” (page4-27) to edit.



**DISP GROUP NAV LINE**

---

Selection values: OFF, 1 to 20

- This is a function to display Navigation line by inputting latitude/longitude.
- “NAV LINE CROSS” function can be used to determine Navigation line cross section.

☞ Refer to “**NAVLINE CROSS**” (page4-7)

- This is to designate block to be displayed out of 20 blocks.

☞ Refer to “**EDIT NAV LINE**” (page4-27) to edit

**DISP GROUP ROUTE (Alternate planned route)**

---

Selection values: OFF, 1 to 20

- This is the function to select blocks of the route to be displayed.
- This is to designate the block to be displayed out of 20 blocks.
- The route is displayed by a thin dotted line in orange color.

☞ Refer to “**EDIT ROUTE (Alternate planned route)**” (page4-28) to edit.

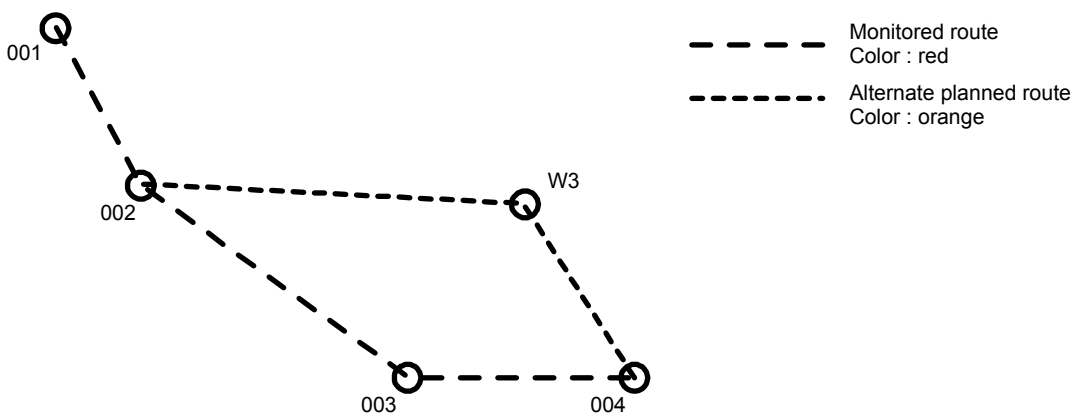

**DISP GROUP EVENT MARK**

---

Selection values: OFF, 1 to 20, ALL

- This is the function to select blocks of event marks to be displayed.
- This is to designate block to be displayed out of 20 blocks in EVENT MARK.

☞ Refer to “**EDIT EVENT MARK**” (page4-28) to edit.

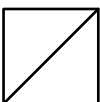

## DISP GROUP AREA

---

Selection values: OFF, 1 to 20

- This is the function to select blocks of the area to be displayed.
- This designates the block to be displayed out of 20 blocks in AREA.

☞ Refer to “**EDIT AREA**” (page4-28) to edit.

It is possible to set within AREA the echo entering alarm or the echo leaving alarm.

☞ Refer to “**MAP AREA**” (page4-6) to edit.

## EDIT COAST LINE

---

- This is to map and edit COAST LINE.
- Edit operation can be performed after designating block number.
- This function is valid by inputting 2 or more positions and each input positions are linked with line.
- Up to 50 points can be input per 1 block.
- Set “DIVIDE” ON at the last point to draw multiple lines in a block.
- Pay attention that “INSERT” will erase 50th point.

☞ Refer to “**DISP GROUP COAST LINE**” (page4-25) for setting display/non display.

\*About EBL1/VRM1 input.

Latitude and longitude can be input by using EBL1 and VRM1.

Switch on [EBL1/VRM1] and put the two intersections at the position where to input.

Select [EBL1/VRM1 Input] and press [ENT] key to input.

## EDIT NAV LINE

---

- This is to map and edit NAVLINE.
- Edit operation can be performed after designating block number.
- This function is valid by inputting 2 or more positions and each input positions are linked with line.
- Up to 50 points can be input per 1 block. 50 points can be divided into A and B having 25 points each. Divide input into A and B to make NAV LINE wider.
- Pay attention that “INSERT” will erase 50th point.

☞ Refer to “**DISP GROUP NAV LINE**” (page4-26) for setting display/non display.

☞ Refer to “**EDIT COAST LINE**” (page4-27) for about EBL1/VRM1 input.

### **EDIT ROUTE (Alternate planned route)**

---

- This is to map and edit ROUTE.
- Edit operation can be performed after designating block number.
- This function is valid by inputting two or more positions and each input positions are linked with line.
- Up to 50 point can be input per one block.
- Pay attention that “INSERT” will erase 50th point.
- ☞ Refer to “**DISP GROUP ROUTE (Alternate planned route)**” (page4-26) for designating display/non display.
- ☞ Refer to “**EDIT COAST LINE**” (page4-27) for about EBL1/VRM1 input.

### **EDIT EVENT MARK**

---

- This is to map and edit EVENT MARK.
- Edit operation can be performed after designating block number.
- Up to 50 point can be input per one block.
- Pay attention that “INSERT” will erase 50th point.
- ☞ Refer to “**DISP GROUP EVENT MARK**” (page4-26) for designating display/non display.
- The own ship position and the cursor position are input with an F key.
- ☞ Refer to “**F (Function key) usage**” (page2-27) for function key input.

### **EDIT AREA**

---

- This is to map and edit AREA.
  - Edit operation can be performed after designating block number.
  - This function is valid by inputting three or more positions and each input positions are linked with line.
  - Up to 50 point can be input per one block.
  - Set “DIVIDE” ON at the last point to draw multiple areas in a block.
  - Pay attention that “INSERT” will erase 50th point.
  - ☞ Refer to “**DISP GROUP AREA**” (page4-27) for designating display/non display.
- It is possible to set the echo entering alarm or the echo leaving alarm within AREA.
- ☞ Refer to “**MAP AREA**” (page4-6) to edit.
  - ☞ Refer to “**EDIT COAST LINE**” (page4-27) for about EBL1/VRM1 input.

### **MONITORED ROUTE**

---

Selection values: OFF, ON

- This is to set up a function to display a route input from external device.
- Route is displayed by bold dotted line in orange color.
- ☞ Refer to “**DISP GROUP ROUTE (Alternate planned route)**” (page4-26).

**WPT ID DISP**

Selection values: OFF, ON

- This is to set up a function to display WPT number of the ROUTE.

**DATUM**

Selection values: W84, W72, S85, P90, XXX (User datum)

- This is to set up DATUM.

**EDIT USER DATUM**

Selection values: three words

- This is to set up name input of USER's geodetic system.

**POSITION OFFSET**

Selection values: EPFS, MAN

This is to select OFFSET input of position.

EPFS: DTM

LAT/LON input is available only when [MAN] is selected.

Selection values: 1.000S to 1.000N

1.000W to 1.000E

**MAN OFFSET**

Selection values: 1.000S to 1.000N, 1.000W to 1.000E

- This is to manually input compensated value of latitude/longitude.

Set [MAINTENANCE] => [I/O] => [OFFSET] to [MAN] before usage of MAN OFFSET.

**DETAIL****EDIT MARK SHAPE**

Selection values: 19 types

This is to set the mark shape for inputting of the mark using F key. The following marks can be selected:



☞ Refer to "F (Function key) usage" (page2-27).

**EDIT MARK LINE**

Selection values: OFF, ON

This is to set the function to connect between own ship and the mark with a dotted line.

After switching this function ON, overlap the cursor on the mark to be connected and push [ENT] key.

Then, the dotted line is displayed. Another push of [ENT] key can hide the dotted line.

## COAST LINE/GPS BUOY

---

Selection values: COAST LINE, GPS BUOY

Either one of COAST LINE or GPS BUOY can be selected.

## GPS BUOY

---

GPS BUOY, of which display is connected to a GPS BUOY's transmitter-receiver made by Taiyo Musen, will receive buoy information sentences (BLV).

A buoy ID can record 10 kinds of information, and time, position and water temperature at 100 points can be recorded per 1 ID. As for the latest data, in addition to time, position and water temperature, course, speed and battery voltage can be recorded.

Examples of display:

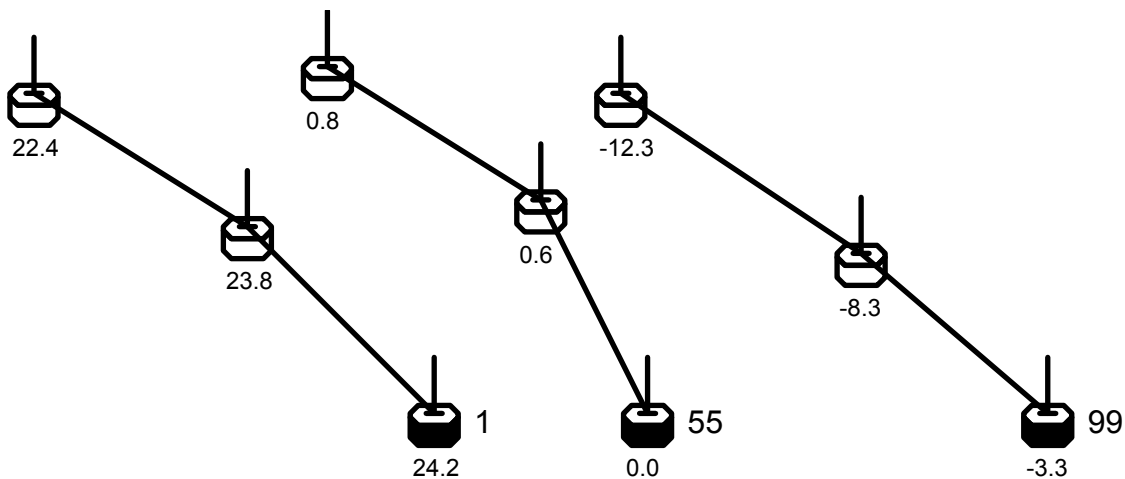

Buoys with same ID will be displayed linked with straight lines. Under each buoy symbol, water temperature can be indicated.

The latest data will be indicated with marked-out symbols, and ID can be also indicated at the right hand side of the symbol as shown in the above examples.

	MENU	
	>MAP	
	>DETAIL	
	>GPS BUOY	
1	NUM DISP	ON
2	WAT TEMP DISP	ON
3	BLOCK NUMBER	1
4	BLOCK CLEAR	>
5	BLOCK DATA	>
6	LOCAL	11/25 16:33:40
	NUMBER	1
	LAT	39°13.600N
	LON	139°46.000E
	CRS	0.0°
	SPD	5kn
	WAT TEMP	-9.8°C
	BATT VOL	12.3V

#### 1. NUM DISP

This is the function to display Buoy IDs at the right sides of the latest data buoy symbols

#### 2. WAT TEMP DISP

This is the function to display water temperature under the buoy symbols.

#### 3. BLOCK NUMBER

This is the function to select block numbers. 1 ID buoy data can be recorded in 1 block.

The following 4 ~ 6 will be applied to the blocks selected in above 3.

#### 4. BLOCK CLEAR

This is the function to deleted buoy data recorded in blocks.

#### 5. BLOCK DATA

This is the function to confirm buoy data in blocks in a list of data.

#### 6. LATEST BUOY DATA

This is the function to display the latest buoy data.

**WPT FLAG**

Selection values: OFF, ON

This is to set display of waypoint flag when there is external input of waypoint.

**LAT/LON LINE**

Selection values: OFF, ON

This is to select display or non-display of latitude and longitude.

**CHART**

Selection values: OFF, ON

This is to set display/non-display of charts.

This menu is displayed only when [KODEN map card of Japan] or [C-MAP card] has been inserted.

The card shall be inserted at the rear of the housing.

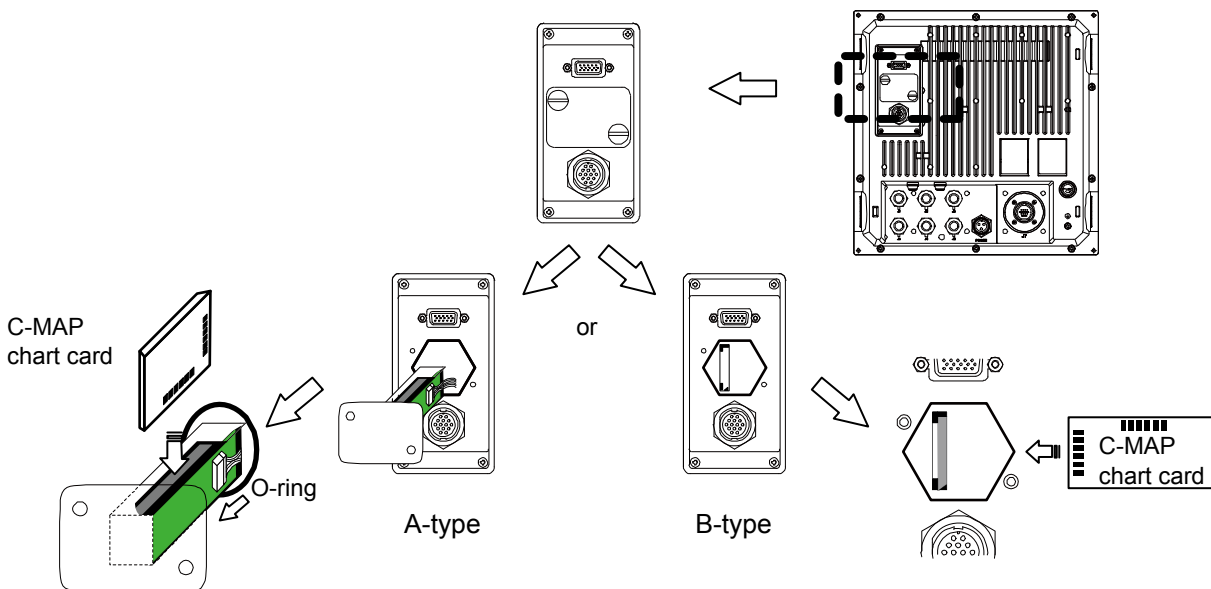

Note:

About C-MAP chart

When a C-MAP chart card for a special area is used, there are cases where no chart could be displayed at some positions or at some ranges.

This is because that there is no most appropriate chart information and not because of failure of the radar. In those cases, please try to change the range to get the chart.

**CHART SELECT**

Selection values: JAPAN, GLOBAL

This is to select the map card to be inserted.

JAPAN: KODEN map card of Japan

GLOBAL: C-MAP card

**CHART DISP SET**

---

This is to set display of a map.

This menu is displayed only when either one of [KODEN map card of Japan] or [C-MAP card] has been inserted.



## 4.6 BRILL

### COLOR

---

Selection values: DAY, NIGHT

- This is to select color change, DAY or NIGHT.

### COLOR ECHO

---

Selection values: WHITE, YELLOW, GREEN, MULTI, USER1, USER2

- Color of ECHO can be set up in 7 levels of color according to signal strength.

### COLOR TRAIL

---

Selection values: BLUE, AMBER, USER1, USER2

- Color of TRAIL can be set up in 7 levels of color according to signal strength.

### COLOR BKGND PPI

---

Selection values: BLACK, BLUE, USER1, USER2

### COLOR BKGND DATA

---

Selection values: BLACK, BLUE, USER1, USER2

### COLOR DATA

---

Selection values: WHITE, GREY, USER1, USER2

### BRIGHTNESS

---

Selection values: 20 to 100

- This is to set up brightness of [ECHO], [TRAIL], [BKGND], [OS / TOOL], [TGT], [MAP / ROUTE], [CURSOR], [DATA], [WARNING] and [ALARM].

\* Every default value of these items is 100.

\* For safety reason, brightness below 20 cannot be designated.

## DETAIL

---

### COLOR OS / TOOL

---

Selection values: WHITE, USER1, USER2

This is to designate the colors of heading line, own ship's vector, EBL, VRM and PI.

 Refer to "USER1 COLOR" (page4-36).

### COLOR TGT

---

Selection values: SKYBLUE, USER1, USER2

This is to designate the colors of TT (ARPA) and AIS targets.

 Refer to "USER1 COLOR" (page4-36).

### COLOR COAST LINE

---

Selection values: WHITE, USER1, USER2

This is to designate the color of coast line.

This is effective only at the time of displaying a map.

 Refer to "USER1 COLOR" (page4-36).

### COLOR NAV LINE

---

Selection values: GREY, USER1, USER2

This is to designate the color of nav-line.

 Refer to "USER1 COLOR" (page4-36).

### COLOR ROUTE

---

Selection values: ORANGE, USER1, USER2

This is to designate the colors of routes.

 Refer to "USER1 COLOR" (page4-36).

### COLOR EVENT MARK

---

Selection values: MAGENTA, USER1, USER2

This is to designate the colors of event marks.

 Refer to "USER1 COLOR" (page4-36).

### COLOR AREA

---

Selection values: MAGENTA, USER1, USER2

This is to designate the colors of areas.

 Refer to "USER1 COLOR" (page4-36).

---

**COLOR OS PAST TRK**

---

Selection values: WHITE, USER1, USER2

This is to designate the color of own ship's track.

 Refer to "USER1 COLOR" (page4-36).

---

**COLOR CURSOR**

---

Selection values: WHITE, USER1, USER2

This is to designate the color of cursor.

 Refer to "USER1 COLOR" (page4-36).

---

**COLOR CHART LAND**

---

Selection values: BROWN, GREEN, LIME, YELLOW, USER1, USER2

This is to designate the color of land.

 Refer to "USER1 COLOR" (page4-36).

---

**USER1 COLOR**

---

This is the function for users to generate colors by themselves.

The items for which colors can be generated are [Echo], [Trail], [Echo Background], [Data Background], [Own Ship/Tool], [Target], [Coast Line], [Nav-Line], Route, [Mark], [Area], [Own ship track], [Cursor], [Data] and [Map Colors].

For [Echo] and [Trails], 7 colors shall be designated due to 7 steps of their images levels.

Colors will be generated by designation of 3 elementary colors of red, green and blue.

---

**USER2 COLOR**

---

This is the same of USER 1 COLOR.

## 4.7 SYSTEM

### INTER SWITCH (Cannot use while transmitting)

This is to set up the case when two radars are connected for use.

\* If either radar fails while two radars are in use, then set the [MODE] of the surviving radar to [INDEPENDENT MASTER] and use it independently.

### MODE

Selection values: INDEPENDENT MASTER, INDEPENDENT SLAVE, DUAL MASTER, DUAL SLAVE, CROSS, MONITOR

INDEPENDENT MASTER: Connection status where one antenna is connected to one radar.

INDEPENDENT SLAVE: Connection status where the dedicated cable is connected to the above-mentioned INDEPENDENT (MASTER), and the image of antenna of INDEPENDENT (MASTER) is displayed.

The antenna cannot be controlled. So, it is impossible to perform the change etc. of pulse width.

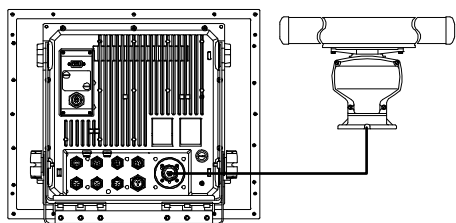

INDEPENDENT MASTER

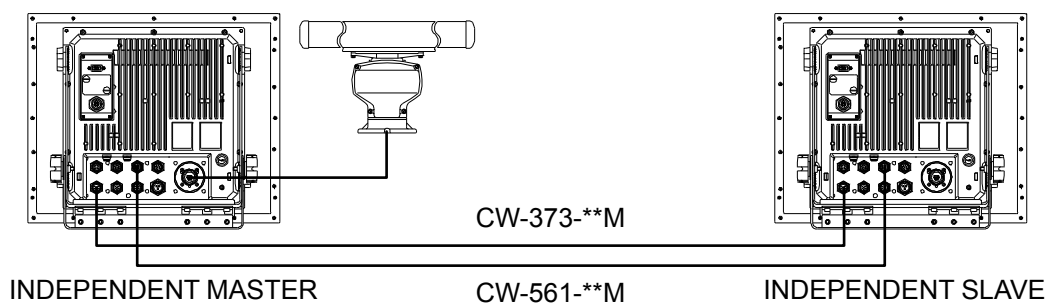

INDEPENDENT MASTER

CW-373-\*\*M

CW-561-\*\*M

INDEPENDENT SLAVE

DUAL MASTER: Connection topology is the same as the above-mentioned INDEPENDENT (MASTER) and INDEPENDENT (SLAVE). But, by this setting, either radar can control the antenna. The radar to which the antenna is connected is DUAL (MASTER).

DUAL SLAVE: The radar to which the antenna is not connected is DUAL (SLAVE).

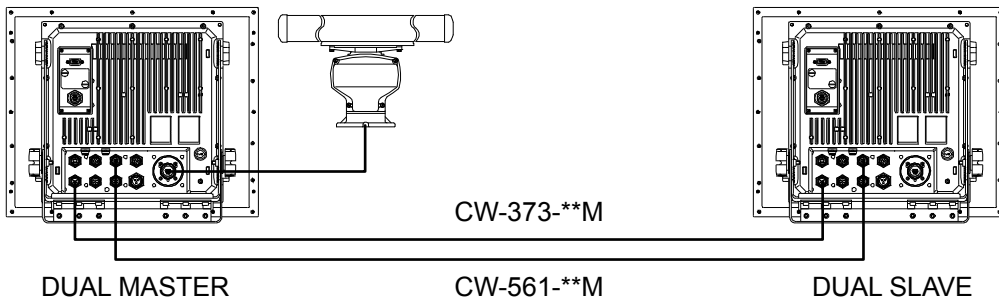

CROSS: In this status, there are two radar to which each antenna is connected. In this status, the antenna that is not connected to its own radar is used.

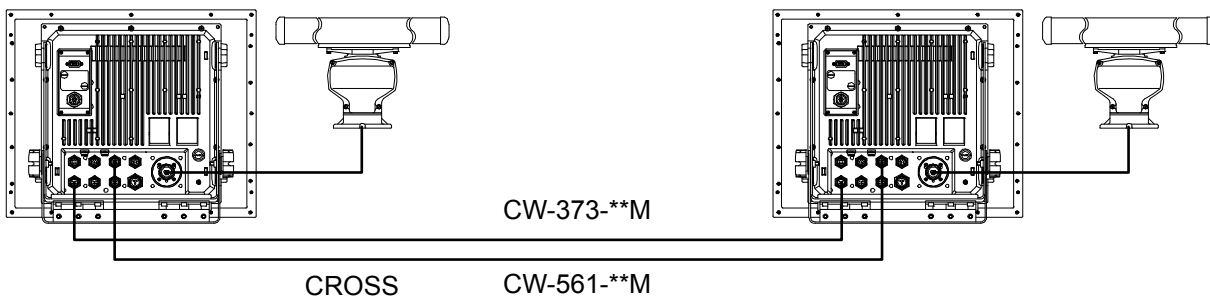

MONITOR: In this status, the antenna is not connected, and a simulator is connected and used.

**ANT POSI**

Selection values: PORT, STBD, FWD, MID, AFT, FWD PORT, FWD STBD, MID PORT, MID STBD, AFT PORT, AFT STBD, UPPER, LOWER

This is to use an inter-switch and to set up the location of antenna to display the image.

**TIME**

Selection values: UTC, LOCAL

· This is to set up time.

### ASSISTANT DISP

Selection values: NAV INFO, TGT OUTLINE, TGT LIST (CPA/TCPA), TGT LIST (BCR/BCT), TGT LIST (BRG/RNG), TGT LIST (LAT/LON), TGT LIST (CRS/SPD), TGT LIST (LABEL), AIS INFO, BIRDVIEW, WIDEVIEW

- This is to set up the display of “ASSISTANT DISPLAY” at the lower right side of the screen.
- Without using a menu, the value can be changed by dragging a cursor to the display part of “selected values (NAV INFO etc.)” and by pressing [ENT] key.

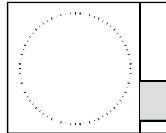

<p><b>NAV INFO</b></p> <p>NAV INFO OS DEPTH WAT TEMP WIND</p> <p>LOPTD</p> <hr/> <p>WPT ID            WPT00 LAT                35°16.13 LON                139°44.71 BRG T             123.4° RNG                123.4N XTD                RIGHT 123.4N</p>	<p><b>TGT OUTLINE</b></p> <p>TGT OUTLINE</p>	<p><b>TGT LIST CPA/TCPA</b></p> <table border="1"> <thead> <tr> <th>TGT ID</th> <th>CPA</th> <th>TCPA</th> <th>SORT : T CPA</th> </tr> </thead> <tbody> <tr><td>100</td><td>▶123.4NM</td><td>1.0min</td><td></td></tr> <tr><td>180</td><td>123.4NM</td><td>2.0min</td><td></td></tr> <tr><td>240</td><td>123.4NM</td><td>3.0min</td><td></td></tr> <tr><td>155</td><td>123.4NM</td><td>4.0min</td><td></td></tr> <tr><td>273</td><td>123.4NM</td><td>5.0min</td><td></td></tr> <tr><td>102</td><td>123.4NM</td><td>6.0min</td><td></td></tr> <tr><td>333</td><td>123.4NM</td><td>7.0min</td><td></td></tr> <tr><td>169</td><td>123.4NM</td><td>8.0min</td><td></td></tr> <tr><td>247</td><td>123.4NM</td><td>9.0min</td><td></td></tr> <tr><td>319</td><td>123.4NM</td><td>10.0min</td><td></td></tr> <tr><td>316</td><td>123.4NM</td><td>11.0min</td><td></td></tr> <tr><td>154</td><td>123.4NM</td><td>12.0min</td><td></td></tr> <tr><td>206</td><td>123.4NM</td><td>13.0min</td><td></td></tr> <tr><td>144</td><td>123.4NM</td><td>14.0min</td><td></td></tr> <tr><td>185</td><td>123.4NM</td><td>15.0min</td><td></td></tr> <tr><td>320</td><td>123.4NM</td><td>16.0min</td><td></td></tr> </tbody> </table>	TGT ID	CPA	TCPA	SORT : T CPA	100	▶123.4NM	1.0min		180	123.4NM	2.0min		240	123.4NM	3.0min		155	123.4NM	4.0min		273	123.4NM	5.0min		102	123.4NM	6.0min		333	123.4NM	7.0min		169	123.4NM	8.0min		247	123.4NM	9.0min		319	123.4NM	10.0min		316	123.4NM	11.0min		154	123.4NM	12.0min		206	123.4NM	13.0min		144	123.4NM	14.0min		185	123.4NM	15.0min		320	123.4NM	16.0min		<p><b>TGT LIST BCR/BCT</b></p> <table border="1"> <thead> <tr> <th>TGT ID</th> <th>BCR</th> <th>BCT</th> <th>SORT : BCR</th> </tr> </thead> <tbody> <tr><td>100</td><td>▶ 0.12NM</td><td>2.98min</td><td></td></tr> <tr><td>180</td><td>0.55NM</td><td>1.63min</td><td></td></tr> <tr><td>240</td><td>0.66NM</td><td>2.70min</td><td></td></tr> <tr><td>155</td><td>1.59NM</td><td>5.46min</td><td></td></tr> <tr><td>273</td><td>2.55NM</td><td>-0.63min</td><td></td></tr> <tr><td>102</td><td>4.66NM</td><td>3.10min</td><td></td></tr> <tr><td>333</td><td>10.90NM</td><td>1.01min</td><td></td></tr> <tr><td>169</td><td>28.84NM</td><td>-16.40min</td><td></td></tr> </tbody> </table>	TGT ID	BCR	BCT	SORT : BCR	100	▶ 0.12NM	2.98min		180	0.55NM	1.63min		240	0.66NM	2.70min		155	1.59NM	5.46min		273	2.55NM	-0.63min		102	4.66NM	3.10min		333	10.90NM	1.01min		169	28.84NM	-16.40min		<p><b>TGT LIST BRG/RNG</b></p> <table border="1"> <thead> <tr> <th>TGT ID</th> <th>BRG T</th> <th>RNG</th> <th>SORT : RNG</th> </tr> </thead> <tbody> <tr><td>100</td><td>▶123.4°</td><td></td><td>1.0NM</td></tr> <tr><td>180</td><td>123.4°</td><td></td><td>2.0NM</td></tr> <tr><td>240</td><td>123.4°</td><td></td><td>3.0NM</td></tr> <tr><td>155</td><td>123.4°</td><td></td><td>4.0NM</td></tr> <tr><td>273</td><td>123.4°</td><td></td><td>5.0NM</td></tr> <tr><td>102</td><td>123.4°</td><td></td><td>6.0NM</td></tr> <tr><td>333</td><td>123.4°</td><td></td><td>7.0NM</td></tr> <tr><td>169</td><td>123.4°</td><td></td><td>8.0NM</td></tr> <tr><td>247</td><td>123.4°</td><td></td><td>9.0NM</td></tr> <tr><td>319</td><td>123.4°</td><td></td><td>10.0NM</td></tr> <tr><td>316</td><td>123.4°</td><td></td><td>11.0NM</td></tr> <tr><td>154</td><td>123.4°</td><td></td><td>12.0NM</td></tr> <tr><td>206</td><td>123.4°</td><td></td><td>13.0NM</td></tr> <tr><td>144</td><td>123.4°</td><td></td><td>14.0NM</td></tr> <tr><td>185</td><td>123.4°</td><td></td><td>15.0NM</td></tr> <tr><td>320</td><td>123.4°</td><td></td><td>16.0NM</td></tr> </tbody> </table>	TGT ID	BRG T	RNG	SORT : RNG	100	▶123.4°		1.0NM	180	123.4°		2.0NM	240	123.4°		3.0NM	155	123.4°		4.0NM	273	123.4°		5.0NM	102	123.4°		6.0NM	333	123.4°		7.0NM	169	123.4°		8.0NM	247	123.4°		9.0NM	319	123.4°		10.0NM	316	123.4°		11.0NM	154	123.4°		12.0NM	206	123.4°		13.0NM	144	123.4°		14.0NM	185	123.4°		15.0NM	320	123.4°		16.0NM
TGT ID	CPA	TCPA	SORT : T CPA																																																																																																																																																																													
100	▶123.4NM	1.0min																																																																																																																																																																														
180	123.4NM	2.0min																																																																																																																																																																														
240	123.4NM	3.0min																																																																																																																																																																														
155	123.4NM	4.0min																																																																																																																																																																														
273	123.4NM	5.0min																																																																																																																																																																														
102	123.4NM	6.0min																																																																																																																																																																														
333	123.4NM	7.0min																																																																																																																																																																														
169	123.4NM	8.0min																																																																																																																																																																														
247	123.4NM	9.0min																																																																																																																																																																														
319	123.4NM	10.0min																																																																																																																																																																														
316	123.4NM	11.0min																																																																																																																																																																														
154	123.4NM	12.0min																																																																																																																																																																														
206	123.4NM	13.0min																																																																																																																																																																														
144	123.4NM	14.0min																																																																																																																																																																														
185	123.4NM	15.0min																																																																																																																																																																														
320	123.4NM	16.0min																																																																																																																																																																														
TGT ID	BCR	BCT	SORT : BCR																																																																																																																																																																													
100	▶ 0.12NM	2.98min																																																																																																																																																																														
180	0.55NM	1.63min																																																																																																																																																																														
240	0.66NM	2.70min																																																																																																																																																																														
155	1.59NM	5.46min																																																																																																																																																																														
273	2.55NM	-0.63min																																																																																																																																																																														
102	4.66NM	3.10min																																																																																																																																																																														
333	10.90NM	1.01min																																																																																																																																																																														
169	28.84NM	-16.40min																																																																																																																																																																														
TGT ID	BRG T	RNG	SORT : RNG																																																																																																																																																																													
100	▶123.4°		1.0NM																																																																																																																																																																													
180	123.4°		2.0NM																																																																																																																																																																													
240	123.4°		3.0NM																																																																																																																																																																													
155	123.4°		4.0NM																																																																																																																																																																													
273	123.4°		5.0NM																																																																																																																																																																													
102	123.4°		6.0NM																																																																																																																																																																													
333	123.4°		7.0NM																																																																																																																																																																													
169	123.4°		8.0NM																																																																																																																																																																													
247	123.4°		9.0NM																																																																																																																																																																													
319	123.4°		10.0NM																																																																																																																																																																													
316	123.4°		11.0NM																																																																																																																																																																													
154	123.4°		12.0NM																																																																																																																																																																													
206	123.4°		13.0NM																																																																																																																																																																													
144	123.4°		14.0NM																																																																																																																																																																													
185	123.4°		15.0NM																																																																																																																																																																													
320	123.4°		16.0NM																																																																																																																																																																													

<p><b>TGT LIST LAT/LON</b></p> <table border="1"> <thead> <tr> <th>TGT ID</th> <th>LAT/LON</th> <th>SORT : RNG</th> </tr> </thead> <tbody> <tr><td>100</td><td>▶ 35°16.137N</td><td></td></tr> <tr><td></td><td>139°44.711E</td><td></td></tr> <tr><td>240</td><td>35°16.137N</td><td></td></tr> <tr><td></td><td>139°44.711E</td><td></td></tr> <tr><td>273</td><td>35°16.137N</td><td></td></tr> <tr><td></td><td>139°44.711E</td><td></td></tr> <tr><td>333</td><td>35°16.137N</td><td></td></tr> <tr><td></td><td>139°44.711E</td><td></td></tr> <tr><td>247</td><td>35°16.137N</td><td></td></tr> <tr><td></td><td>139°44.711E</td><td></td></tr> <tr><td>316</td><td>35°16.137N</td><td></td></tr> <tr><td></td><td>139°44.711E</td><td></td></tr> <tr><td>206</td><td>35°16.137N</td><td></td></tr> <tr><td></td><td>139°44.711E</td><td></td></tr> <tr><td>185</td><td>35°16.137N</td><td></td></tr> <tr><td></td><td>139°44.711E</td><td></td></tr> </tbody> </table>	TGT ID	LAT/LON	SORT : RNG	100	▶ 35°16.137N			139°44.711E		240	35°16.137N			139°44.711E		273	35°16.137N			139°44.711E		333	35°16.137N			139°44.711E		247	35°16.137N			139°44.711E		316	35°16.137N			139°44.711E		206	35°16.137N			139°44.711E		185	35°16.137N			139°44.711E		<p><b>TGT LIST COG/SOG</b></p> <table border="1"> <thead> <tr> <th>TGT ID</th> <th>COG</th> <th>SOG</th> <th>SORT : RNG</th> </tr> </thead> <tbody> <tr><td>100</td><td>▶123.4NM</td><td>1.0kn</td><td></td></tr> <tr><td>180</td><td>123.4NM</td><td>2.0kn</td><td></td></tr> <tr><td>240</td><td>123.4NM</td><td>3.0kn</td><td></td></tr> <tr><td>155</td><td>123.4NM</td><td>4.0kn</td><td></td></tr> <tr><td>273</td><td>123.4NM</td><td>5.0kn</td><td></td></tr> <tr><td>102</td><td>123.4NM</td><td>6.0kn</td><td></td></tr> <tr><td>333</td><td>123.4NM</td><td>7.0kn</td><td></td></tr> <tr><td>169</td><td>123.4NM</td><td>8.0kn</td><td></td></tr> <tr><td>247</td><td>123.4NM</td><td>9.0kn</td><td></td></tr> <tr><td>319</td><td>123.4NM</td><td>10.0kn</td><td></td></tr> <tr><td>316</td><td>123.4NM</td><td>11.0kn</td><td></td></tr> <tr><td>154</td><td>123.4NM</td><td>12.0kn</td><td></td></tr> <tr><td>206</td><td>123.4NM</td><td>13.0kn</td><td></td></tr> <tr><td>144</td><td>123.4NM</td><td>14.0kn</td><td></td></tr> <tr><td>185</td><td>123.4NM</td><td>15.0kn</td><td></td></tr> <tr><td>320</td><td>123.4NM</td><td>16.0kn</td><td></td></tr> </tbody> </table>	TGT ID	COG	SOG	SORT : RNG	100	▶123.4NM	1.0kn		180	123.4NM	2.0kn		240	123.4NM	3.0kn		155	123.4NM	4.0kn		273	123.4NM	5.0kn		102	123.4NM	6.0kn		333	123.4NM	7.0kn		169	123.4NM	8.0kn		247	123.4NM	9.0kn		319	123.4NM	10.0kn		316	123.4NM	11.0kn		154	123.4NM	12.0kn		206	123.4NM	13.0kn		144	123.4NM	14.0kn		185	123.4NM	15.0kn		320	123.4NM	16.0kn		<p><b>TGT LIST LABEL</b></p> <table border="1"> <thead> <tr> <th>TGT ID</th> <th>LABEL</th> <th>SORT : RNG</th> </tr> </thead> <tbody> <tr><td>100</td><td>▶1234567890</td><td></td></tr> <tr><td>180</td><td>ABCDEFGHIJ</td><td></td></tr> <tr><td>240</td><td>1234567890</td><td></td></tr> <tr><td>155</td><td>ABCDEFGHIJ</td><td></td></tr> <tr><td>273</td><td>1234567890</td><td></td></tr> <tr><td>102</td><td>ABCDEFGHIJ</td><td></td></tr> <tr><td>333</td><td>1234567890</td><td></td></tr> <tr><td>169</td><td>ABCDEFGHIJ</td><td></td></tr> <tr><td>247</td><td>1234567890</td><td></td></tr> <tr><td>319</td><td>ABCDEFGHIJ</td><td></td></tr> <tr><td>316</td><td>1234567890</td><td></td></tr> <tr><td>154</td><td>ABCDEFGHIJ</td><td></td></tr> <tr><td>206</td><td>1234567890</td><td></td></tr> <tr><td>144</td><td>ABCDEFGHIJ</td><td></td></tr> <tr><td>185</td><td>1234567890</td><td></td></tr> <tr><td>320</td><td>ABCDEFGHIJ</td><td></td></tr> </tbody> </table>	TGT ID	LABEL	SORT : RNG	100	▶1234567890		180	ABCDEFGHIJ		240	1234567890		155	ABCDEFGHIJ		273	1234567890		102	ABCDEFGHIJ		333	1234567890		169	ABCDEFGHIJ		247	1234567890		319	ABCDEFGHIJ		316	1234567890		154	ABCDEFGHIJ		206	1234567890		144	ABCDEFGHIJ		185	1234567890		320	ABCDEFGHIJ		<p><b>AIS INFO</b></p> <p>SELECTED AIS INFO</p> <p>CLASS            A</p> <p>RAIM            OFF</p> <p>TYPE            25.4m</p> <p>CALL SIGN      J1KODEN</p> <p>IMO             123456789</p> <p>DRAUGHT       25.4m</p> <p>DESTINATION</p> <p>YOKOHAMA JAPAN</p> <p>ETA UTC        2/03 4:05</p> <p>DIMENSION</p> <p>                  A 511m</p> <p>                  B 511m</p> <p>                  C 83m</p> <p>                  D 83m</p> <p>DTE            OFF</p> <p>DEVICE        COMBINED</p> <p>&lt;BBK&gt; XXXXXXXXXXXXXXXX</p> <p>&lt;ABK&gt; XXXXXXXXXXXXXXXX</p> <p>Scroll message</p>	<p><b>BIRD VIEW</b></p> <p>BIRDVIEW</p>
TGT ID	LAT/LON	SORT : RNG																																																																																																																																																																												
100	▶ 35°16.137N																																																																																																																																																																													
	139°44.711E																																																																																																																																																																													
240	35°16.137N																																																																																																																																																																													
	139°44.711E																																																																																																																																																																													
273	35°16.137N																																																																																																																																																																													
	139°44.711E																																																																																																																																																																													
333	35°16.137N																																																																																																																																																																													
	139°44.711E																																																																																																																																																																													
247	35°16.137N																																																																																																																																																																													
	139°44.711E																																																																																																																																																																													
316	35°16.137N																																																																																																																																																																													
	139°44.711E																																																																																																																																																																													
206	35°16.137N																																																																																																																																																																													
	139°44.711E																																																																																																																																																																													
185	35°16.137N																																																																																																																																																																													
	139°44.711E																																																																																																																																																																													
TGT ID	COG	SOG	SORT : RNG																																																																																																																																																																											
100	▶123.4NM	1.0kn																																																																																																																																																																												
180	123.4NM	2.0kn																																																																																																																																																																												
240	123.4NM	3.0kn																																																																																																																																																																												
155	123.4NM	4.0kn																																																																																																																																																																												
273	123.4NM	5.0kn																																																																																																																																																																												
102	123.4NM	6.0kn																																																																																																																																																																												
333	123.4NM	7.0kn																																																																																																																																																																												
169	123.4NM	8.0kn																																																																																																																																																																												
247	123.4NM	9.0kn																																																																																																																																																																												
319	123.4NM	10.0kn																																																																																																																																																																												
316	123.4NM	11.0kn																																																																																																																																																																												
154	123.4NM	12.0kn																																																																																																																																																																												
206	123.4NM	13.0kn																																																																																																																																																																												
144	123.4NM	14.0kn																																																																																																																																																																												
185	123.4NM	15.0kn																																																																																																																																																																												
320	123.4NM	16.0kn																																																																																																																																																																												
TGT ID	LABEL	SORT : RNG																																																																																																																																																																												
100	▶1234567890																																																																																																																																																																													
180	ABCDEFGHIJ																																																																																																																																																																													
240	1234567890																																																																																																																																																																													
155	ABCDEFGHIJ																																																																																																																																																																													
273	1234567890																																																																																																																																																																													
102	ABCDEFGHIJ																																																																																																																																																																													
333	1234567890																																																																																																																																																																													
169	ABCDEFGHIJ																																																																																																																																																																													
247	1234567890																																																																																																																																																																													
319	ABCDEFGHIJ																																																																																																																																																																													
316	1234567890																																																																																																																																																																													
154	ABCDEFGHIJ																																																																																																																																																																													
206	1234567890																																																																																																																																																																													
144	ABCDEFGHIJ																																																																																																																																																																													
185	1234567890																																																																																																																																																																													
320	ABCDEFGHIJ																																																																																																																																																																													

**WIDE VIEW**

WIDEVIEW

## **TGT LIST SORT**

---

Selection values: CPA, TCPA, BCR, BCT, RNG, TGT, SEL

This is a list of ASSISTANT DISP. This is an item to select the sorting method.

[TGT LIST SORT] can be changed directly at the right side of LIST without using a menu.

CPA: It is displayed with the nearest first from the top of screen.

TCPA: It is displayed with the shortest first from the top of screen.

BCR: It is displayed with the nearest first from the top of screen.

BCT: It is displayed with the shortest first from the top of screen.

RNG: It is displayed with the nearest first from the top of screen.

TGT: It is displayed with the nearest to the selected target first from the top of screen.

SEL: The only selected targets are displayed with the newest order first from the top of screen.

BCR: When a target comes across own ship bearing, the distance between the crossing point and own ship is displayed.

BCT: When a target comes cross own ship bearing, the time between present time and the crossing time is displayed.

## **USER**

---

Selection values: 1 to 4

Four kinds of setting values can be used by changing the setup value after selecting the number.

It enables plural users to use different setting value without the need of changing the value in each case.

User's name can be changed (within 10 characters) for selection of a value 1 to 4.

## **EDIT USER NAME**

---

Selection values: 10 words

This function enables USER to change the number to save the setting value.

## **SOUND**

---

Selection values: OFF, ON

This is to set up ON/OFF of buzzer sound of operating panel.

## **FREQUENCY**

---

Selection values: 1 to 7

This is to set up the frequency of buzzer sound of operating panel.

The larger the value is the higher the frequency of sound is.

## **KEY CLICK**

---

Selection values: OFF, ON

This is to set up a function of ON/OFF of click sound when the key is pressed.

## **BITE**

---

### **ALARM TEST**

---

Selection values: OFF, ON

 Refer to “**No alarm sound**” (page7-2)

### **PANEL TEST**

---

 Refer to “**Operation unit (panel) key is not operationa**” (page7-3)

### **DIAGNOSE TT**

---

 Refer to “**TT (ARPA) is not operational (DIAGNOSE TT)**” (page7-4)

### **DIAGNOSE AIS**

---

 Refer to “**No AIS display**” (page7-5)

### **SERIAL SEL**

---

Selection value: NAV, EPFS, SDME, GYRO

 Refer to “**Need to confirm serial input**” (page7-6)

### **SERIAL MONITOR**

---

 Refer to “**Need to confirm serial input**” (page7-6)

### **ANT MONITOR**

---

 Refer to “**No video display**” (page7-7)

### **TOTAL HOUR**

---

Display of total operating time of the radar.

### **TX HOUR**

---

Total transmitting time of the radar will be displayed. This gives an idea for exchange of components with lifetime.

Reset after components have been exchanged.

 Refer to “**TX HOUR (Cannot use while transmitting)**” (page4-53)

### **VERSION**

---

Display of version of the radar.



## DETAIL

---

### SOUND EXT BUZZER

---

Selection values: OFF, CONTINUE, INTERVAL

This is to set operation of the external buzzer line of J1.

The line for the external buzzer is normally short-circuited and opens at alarm generation.

OFF: Even when alarm has been generated, the line remains short-circuited.

CONTINUE: During alarm generation, the line always opens.

INTERVAL: During alarm generation, the line repeats the short-circuited state and open state periodically.

### LANG

---

Selection values: ENGLISH, 日本語

This is to set up language to be used.

### MOTOR SPEED

---

Selection values: OFF, 0.0625, 0.125, 0.25, 0.5, 1, 1.5, 2, 3, 4, 6, 8, 12, 16, 24, 32, 36, 48, 72, 96, 144

This is to set the range where the antenna can rotate fast.

The antenna rotates fast in the range of the set value and less.

### DISP INFO

---

Selection values: OFF, ON

This is to set display/non-display of information displayed on echo screen.

When this is OFF, the echo screen becomes easy to view. However, the set values such as [PROCESS] can not be changed. Therefore, the functions to be changed are required to be allocated to F key.

 Refer to “**F (Function key) usage**” (page2-27).

### BIRDVIEW

---

This is to set the bird view function contained in ASSISTANT DISP.

## 4.8 MAINTENANCE

### START UP

---

#### TUNE

---

Selection values: AUTO, MAN

 Refer to “**Tuning method**” (page1-1)

#### AUTO ADJ

---

Selection values: 0 to 100

 Refer to “**Tuning method**” (page1-1)

#### MAN ADJ

---

Selection values: 0.0 to 100.0

 Refer to “**Tuning method**” (page1-1)

#### HL OFFSET

---

Selection values: -180.0 to 180.0

 Refer to “**Picture bearing adjustment (HL OFFSET)**” (page1-2)

#### TX DELAY

---

Selection values: 0 to 100

 Refer to “**Adjustment of transmitting delay time (TX DELAY)**” (page1-3)

#### ANT HEIGHT

---

Selection values: 0 - 5m, 5 – 10m, 10m – 20m, 20m or more

 Refer to “**Adjustment of transmitting delay time (TX DELAY)**” (page1-3)

#### ANT CABLE

---

Selection values: 20m, 40m, 60m

 Refer to “**Setup antenna cable length**” (page1-4)

#### MBS (Main Bang Suppression)

---

Selection values: 0 to 30

 Refer to “**Setup of MBS (Main Bang Suppression) value**” (page1-4)

#### RESET

---

Selection values: CANCEL, GO

This is to restore STARTUP setting value to initial value.

#### FUNCTION KEY F1 to F6

---

 Refer to “**F (Function key) usage**” (page2-27)

## I / O

---

### HDG

---

Selection values: AUTO, THS, HDT, HDG, HDM, VTG, RMC, RMA, MAN

\* Input of heading bearing.

Be aware that various functions become unusable without input of heading bearing.

Following is examples of functions affected.

- C UP mode, N UP mode
- True mode of Vector, trail and etc.
- TT (ARPA).
- AIS.
- Map and Chart function.

### HDG OFFSET

---

Selection values: 0.0 to 359.9°

This is to set up compensation value for error heading line signal.

### STW (Speed Through the Water)

---

Selection values: AUTO, VHW, VBW, VTG, RMC, RMA, MAN

This is to select input value of water speed.

 Refer to “**Low or doubtful integrity information display**” (page4-47)

Manual input is available only when [MAN] is selected.

Selection values: 0.0 to 100.0kn

 Refer to “**STAB MODE**” (page3-2)

### COG / SOG

---

Selection values: AUTO, VBW, VTG, RMC, RMA, CURRENT

This is to select COG / SOG input source.

CURRENT: The course and speed obtained by deducting SET/DRIFT values from the course through water and the speed through water are used as COG/SOG.

 Refer to “**SET / DRIFT**” (page4-45)

 Refer to “**Low or doubtful integrity information display**” (page4-47)

## POSITION

---

Selection values: AUTO, GNS, GGA, GLL, RMC, RMA, MAN

This is to select position input source.

 Refer to “**Low or doubtful integrity information display**” (page4-47)

LAT/LON input is available only when [MAN] is selected.

Selection values: 90°00.000S to 90°00.000N

180°00.000W to 180°00.000E

## POSITION OFFSET

---

Selection values: MAN, DTM

This is to select OFFSET input of position.

LAT/LON input is available only when [MAN] is selected.

Selection values: 1.000S to 1.000N

1.000W to 1.000E

## POSITION DATUM

---

This is to display DATUM information in the input sentence DTM when EPFS is selected by Position offset.

## SET / DRIFT

---

Selection values: MAN, VDR

Bearing/Speed input is available only when [MAN] is selected.

Selection values: 0.0° to 359.9°

0.0kn to 100.0kn

## TIME

---

Selection values: ZDA, CLOCK

CLOCK: Use embedded clock time.

TIME ZONE input and CLOCK SET input are available only when [CLOCK] is selected.

## DETAIL

---

### OUTPUT NAV

---

Selection values: 0.0sec to 10.0sec

This is to set up transmitting interval of sentence (DTM, GLL, HDT, ROT, RSD, OSD, THS, TLB, TLL, TTD, TTM, VBW, VDR, VHW, VTG, ZDA) being transmitted from NAV connector.

### OUTPUT EPFS

---

Selection values: 0.0sec to 10.0sec

This is to set up transmitting interval of sentence (DTM, GLL, HDT, ROT, RSD, OSD, THS, TLB, TLL, TTD, TTM, VBW, VDR, VHW, VTG, ZDA) being transmitted from EPFS connector.

### TLL OUT

---

Selection values: TT, MARK, TARGET

This is to set up TLL output.

TT: The latitude and longitude of TT (ARPA) tracking target are output at the interval set by the [OUTPUT NAV] and [OUTPUT EPFS].

Mark: The position registered at the time of registration of a mark using [Mark cursor] or [Mark own ship] of F key is output.

Target: The position of the cursor in use of [TLL output] of F key is output.

When the cursor is in the state of non-display such as during display of the menu, etc., this becomes invalid.

### ALR OUT SEL

---

Selection values: NAV, EPFS, SDME, GYRO

This is to select connector that output ALR sentence.

### INPUT

---

Selection values: ALL, NAV, EPFS, SDME, GYRO

This is to select connector that enables input sentence (see below).

Input sentence: BWC, DBT, DPT, DTM, GGA, GLC, GLL, GNS, HDG, HDM, HDT, MTW, RMA, RMB, RMC, ROT, RTE, THS, VBW, VDR, VHW, VTG, WPL, XTE, ZDA

1: NAV, 2: EPFS, 3: SDME, 4: GYRO

[●]: Radar is receiving the Display of version of the radar valid sentence.

---

**FORMAT**

---

Selection values: 61162-1, 61162-2, NSK

This is to set up communication format of NAV, EPFS, SDME and GYRO connectors.

61162-1: Baud rate 4800

61162-2: Baud rate 38400

NSK: This is the format for NSK only.

---

**KGC-1 SET**

---

Initialization and compensation are available.

At the time of installation, initialization is a must.

---

**NSK SET**

---

Initialization and compensation are available.

At the time of installation, initialization is a must.

---

**SENTENCE SET**

---

Selection values: OFF, ON

This is a function to select use or nonuse of input of ship bearing, ship speed, and ship latitude/longitude.

When there is no input and a radar is used alone, all shall be switched off.

---

**Low or doubtful integrity information display**

---

Figure values displayed on the screen turn red when the input data is Invalid.

Certain functions such as TT (ARPA), AIS, etc. cannot be used when the information of ship's bearing, speed or position at the upper right of the screen are displayed in red.

Functions are not available even if input sentence is correct unless talker device, status and mode indicator are valid.

---

**OS PROFILE (Cannot use while transmitting)**

---

This is to set up own-ship profile and ANT location.

A, B, C and D designate distance of profile from CCRP.

“dx”, “dy” designate distance of ANT location from CCRP.

 Refer to “**Setup own ship profile (Cannot use on transmitting)**” (page1-5)

**SECTOR MUTE (Cannot use while transmitting)**

---

SECTOR MUTE is the function enabling you to stop transmission to designated direction when there are hazardous objects near an antenna location or near a human body.

Using this function enables you to restrain creation of false image and to secure safety for human body.

\*When using SECTOR MUTE, it takes much time to detect optimum value in auto tuning at the start of transmission and change of range. Therefore manual tuning is recommended to use when using SECTOR MUTE.

 Refer to “**Tuning method**” (page1-1)

\*The transmission ON/OFF starting angle of the SECTOR MUTE might be unstable to a set angle by maximum  $\pm 5^\circ$ .

**MUTE**

---

Selection values: OFF, ON

**START**

---

Selection values:  $0^\circ$  to  $359^\circ$

This is to set up the starting angle of SECTOR MUTE.

**END**

---

Selection values:  $0^\circ$  to  $359^\circ$

This is to set up the ending angle of SECTOR MUTE.

## PRESET

---

This is a setting adjustment for GAIN, SEA, RAIN etc.

## GAIN MAN

---

Selection values: 0 to 255

This is to designate the maximum value of GAIN control.

- 1** Set range to 6NM.  
Set GAIN knob to the maximum position.  
Set RAIN knob to the minimum position by setting RAIN to DIFF (Differentiation) mode.  
Set SEA knob to the minimum position by setting SEA to MAN mode.
- 2** Change GAIN MAN setting value so that background noise is faintly displayed in full screen.

\* Though setting of a small value makes fine adjustment of GAIN available, it decreases the maximum gain.

\* Though setting of a large value increases the maximum gain, it makes fine adjustment of GAIN difficult.

## GAIN OFFSET BW

---

Selection values: -127 to 127

This is to compensate difference of GAIN with pulse width.

## SEA AUTO LAND

---

Selection values: 0 to 200

This is to set up strength of AUTO SEA when own-ship stayed in harbor or canal.

Set up a value in harbor so that the quay side is clearly displayed and fairway buoys are not fade-out.

\* Pay attention that small targets may fade-out in case of too large setting value.

## SEA AUTO SEA

---

Selection values: 0 to 200

This is to set up strength of AUTO SEA when own ship at sea.

Adjust the set value so that sea clutter can be slightly seen at open sea at least 1 NM distant from land.

\* Pay attention that small targets may fade-out in case of too large setting value.



## SEA MAN MAX

---

Selection values: 0 to 255

This is to set up the maximum value of SEA control.

- 1** Set range to 24NM.  
Set GAIN knob to the maximum position.  
Set RAIN knob to the minimum position by setting RAIN to DIFF (Differentiation) mode.  
Set SEA knob to the maximum position by setting SEA to MAN mode.
- 2** Change SEA MAN MAX setting value so that background noise disappears to 10NM.

\*Set a large value for SEA MAN MAX when sea clutter is stronger than usual in bad weather and sea clutter remains even when SEA volume is set to the maximum position.

\*Though setting of a large value may increase suppression function, fine adjustment of SEA becomes difficult.

## SEA MAN MIN

---

Selection values: 0 to 100

This is to set up either to limit the adjustment range for fine adjustment of SEA knob, or to obtain suppression effect even at the minimum setting of SEA knob.

\* Pay attention that setting of a large value may fade out small targets because of suppression effect even when SEA knob is set to the minimum position.

## SEA MAX OFFSET

---

Selection values: -127 to 127

This is to set up SEA strength for each pulse width.

SEA knob adjustment (SEA MAN) is not required at the time of range change by this setting-up.

\*Execute VIDEO SETUP before this setting-up.

- 1** Set range to 0.75NM (pulse width SP).  
Set GAIN knob to 80% position.  
Set RAIN knob to the minimum position by setting RAIN to DIFF mode.  
Set SEA knob to the maximum position by setting SEA to MAN mode.
- 2** Turn SEA knob clockwise so that the stable target near 0.75NM becomes 6th gradation.  
(There are 7 gradation levels for echo display brilliance in total and 7th is the maximum).
- 3** Operate [RANGE] key or [SP/LP] key to change pulse width from SP to MP1.
- 4** Change MP1 setting value of SEA MAX OFFSET so that step 2 target becomes the 6th gradation.
- 5** Similarly, adjust for MP2, MP3, MP4, LP1, LP2 (25kW only) pulse width in the same way.

Comparison target can be changed according to change to pulse length and range.

However a common target is recommended to be used for adjacent pulse lengths.

## RAIN MODE

---

Selection values: DIFF (Differentiation), CFAR (Constant False Alarm Rate)

There are two modes of DIFF and CFAR for clutter (sea, rain and snow) suppression method.

DIFF (FTC): The clutter is suppressed with combination of GAIN, SEA (Manual, Auto) and RAIN by using traditional method.

CFAR: Semi-automatic clutter suppression function.

As clutter suppression degree may change by operator, the degree can be changed by adjusting RAIN.

As it is automatically adjusted, GAIN and SEA become no-operational.

Differently from DIFF, target such as ship etc. will not become smaller.

 Refer to “**Reject rain/snow clutter (anti-RAIN)**” (page2-10)

## RAIN MAX

---

Selection values: 0 to 255

This is to set up the maximum value of RAIN knob, when RAIN mode is DIFF.

RAIN knob variable range is determined by difference of RAIN MAX and RAIN MIN.

\*Strong rain cloud may not be faded out if the set value is too small.

\*Small targets may fade out if the set value is too large.

## RAIN MIN

---

Selection values: 0 to 255

This is to set up the minimum value of RAIN knob, when RAIN mode is DIFF.

RAIN knob variable range is determined by difference of RAIN MAX and RAIN MIN.

\*Small targets may fade out if the set value is too large.

## CFAR MAX

---

Selection values: 0 to 255

This is to set up the maximum value of RAIN knob, when RAIN mode is CFAR.

\*Strong rain cloud may not be faded out if the set value is too small.

\*Small targets may fade out if the set value is too large.

## CFAR MIN

---

Selection values: 0 to 255

This is to set up the minimum value of RAIN knob, when RAIN mode is CFAR.

RAIN knob variable range is determined by difference of CFAR MAX and CFAR MIN.

\* Small targets may fade out if the set value is too large.

## MBS (Main Bang Suppression)

---

Selection values: 0 to 30

 Refer to “**Setup of MBS (Main Bang Suppression) value**” (page1-4)

## TT (ARPA) TGT LEVEL

---

Selection values: 0 to 30

This is to set up the intensity level of target to acquire with TT (ARPA).

- \* The low level easily acquires small and weak targets. But, noise may be acquired if the level is too low.
- \* The high level does not acquire noise and easily acquires target ship only. But, target may be missed if the level is too high. Pay attention to that.

## VIDEO SETUP

---

Selection values: 0 to 255

This is to set up signal level to display brilliance gradation for each transmitting pulse width.

Wider brilliance difference between LOW LEVEL and HIGH LEVEL increases the display gradation of dynamic range large.

Set up LOW LEVEL to start with.

### • LOW LEVEL

This is to set up display brilliance of the minimum signal level.

- 1** Set range to 6NM (pulse width LP1).  
Set GAIN knob to the maximum position.  
Set RAIN knob to the minimum position in DIFF (Differentiation) mode for RAIN.  
Set SEA knob to the minimum position in MAN mode for SEA.
- 2** Change the LOW LEVEL setting value so that background noise is displayed weakly.
- 3** Confirm background noise is completely fade-out by setting GAIN knob to the minimum position.
  - \* If the setting value is too small, the noise does not fade out even at the minimum setting of GAIN knob.
  - \* If the setting value is too large, targets are not displayed.

### • HIGH LEVEL

- 1** Set range to 6NM (pulse width LP1).  
Set GAIN knob to the maximum position.  
Set RAIN knob to the minimum position in DIFF mode for RAIN.  
Set SEA knob to the minimum position in MAN mode for SEA.
- 2** Adjust GAIN knob to set stable strength target to the 6th gradation. (There are 7 gradation levels for echo display brilliance in total and 7th is the maximum).
- 3** Operate [RANGE] key or [SP/LP] key to change pulse width from LP1 to LP2 (25kw only).
- 4** Adjust HIGH LEVEL LP2 to set previously detected target to be the 6th gradation.
- 5** Similarly, adjust MP4, MP3, MP2, MP1 and SP in the same way.

## **BACKUP (Cannot use while transmitting)**

---

This item is about the backup of setting value.

### **SETUP LOAD**

---

Selection values: CANCEL, GO

 Refer to “**Inside save of setup data at the time of setting up (Cannot use while transmitting)**” (page1-6)

### **SETUP SAVE**

---

Selection values: CANCEL, GO

 Refer to “**Inside save of setup data at the time of setting up (Cannot use while transmitting)**” (page1-6)

### **EXT LOAD**

---

Selection values: CANCEL, GO

 Refer to “**External save of setup (Cannot use on transmitting)**” (page1-10)

### **EXT SAVE**

---

Selection values: CANCEL, GO

 Refer to “**External save of setup (Cannot use on transmitting)**” (page1-10)

## **TOTAL HOUR (Cannot use while transmitting)**

---

Selection values: CANCEL, RESET

This is a function to reset total operation time of radar.

## **TX HOUR (Cannot use while transmitting)**

---

Selection values: CANCEL, RESET

This is a function to reset total transmission time of antenna.

### 4.9 Menu configuration

RADAR	TUNE MAN ADJ	→ 0.0 to 100.0	
ALARM	TRAIL		
OS / TGT	TRUE / REL	→ TRUE, REL	
TOOL	TIME	→ OFF, PERM, 30sec, 1min, 3min, 6min, 12min, 24min, 48min	
MAP	SHAPE	→ 	
BRILL	DETECT LEVEL	→ 1 to 6	
SYSTEM	RESET	→ CANCEL, GO	
MAINTENANCE	OFF CENT POINT	→ CURSOR, OPPOSITE	
	AUTO OFF CENT	→ OFF, ON	
	TM RESET	Action	
	C UP RESET	Action	
	DETAIL		
	ECHO		
	ECHO ALARM	→ OFF, EDIT, ON	
	BRG REL		
	WIDTH		
	RNG		
	DEPTH		
	MODE	→ IN, OUT	
	DETECT LEVEL	→ 1 to 7	
	MAP AREA	→ OFF, IN, OUT	
	DETECT LEVEL	→ 1 to 7	
	TGT		
	CPA / TCPA	→ OFF, ON	
	AUTO ACQ	→ OFF, ON	
	GZ	→ OFF, EDIT, ON	
	BRG REL		
	WIDTH		
	RNG		
	DEPTH		
	AIS		
	SLEEPING LOST	→ OFF, ON	
	NO HDG / COG	→ OFF, ON	
	NAVLINE CROSS	→ OFF, ON	
	PRIORITY	→ NONE, RADAR, AIS, NAV, EPFS, SDME, GYRO	
	LIST		
	HISTORY LIST		
	DETAIL		
	TM RESET MODE	→ OPPOSITE, CURSOR, CENTER	
	TM RESET REF	→ HFG, CRS	
	HOLD	Action	
	ZOOM	Action	
	RANGE UNIT	→ NM, km, sm, kf	
	ROTATION MARGIN	→ 0.0° to 30.0°	
	ROTATION SPEED	→ 1 to 50	
	DISPLAY CENTER	→ ANT, CCRP	
	TRAIL		
	RANGE KEEP	→ OFF, ON	
	TIME KEEP	→ OFF, ON	
	C UP KEEP	→ NORMAL, C UP FIX	
	MODE KEEP	→ OFF, ON	
	MOVE	→ COURSE, POSITION	
	REL MODE	→ HDG, TRUE	
	H UP OFFSET	→ 0.0° to 359.9°	
	ALL PPI	→ OFF, ON	
	ECHO MOVE	→ SCAN, SWEEP	
	FERRY MODE	→ OFF, 1, 2	
	AIS		
	MESSAGE	→ OFF, ON	

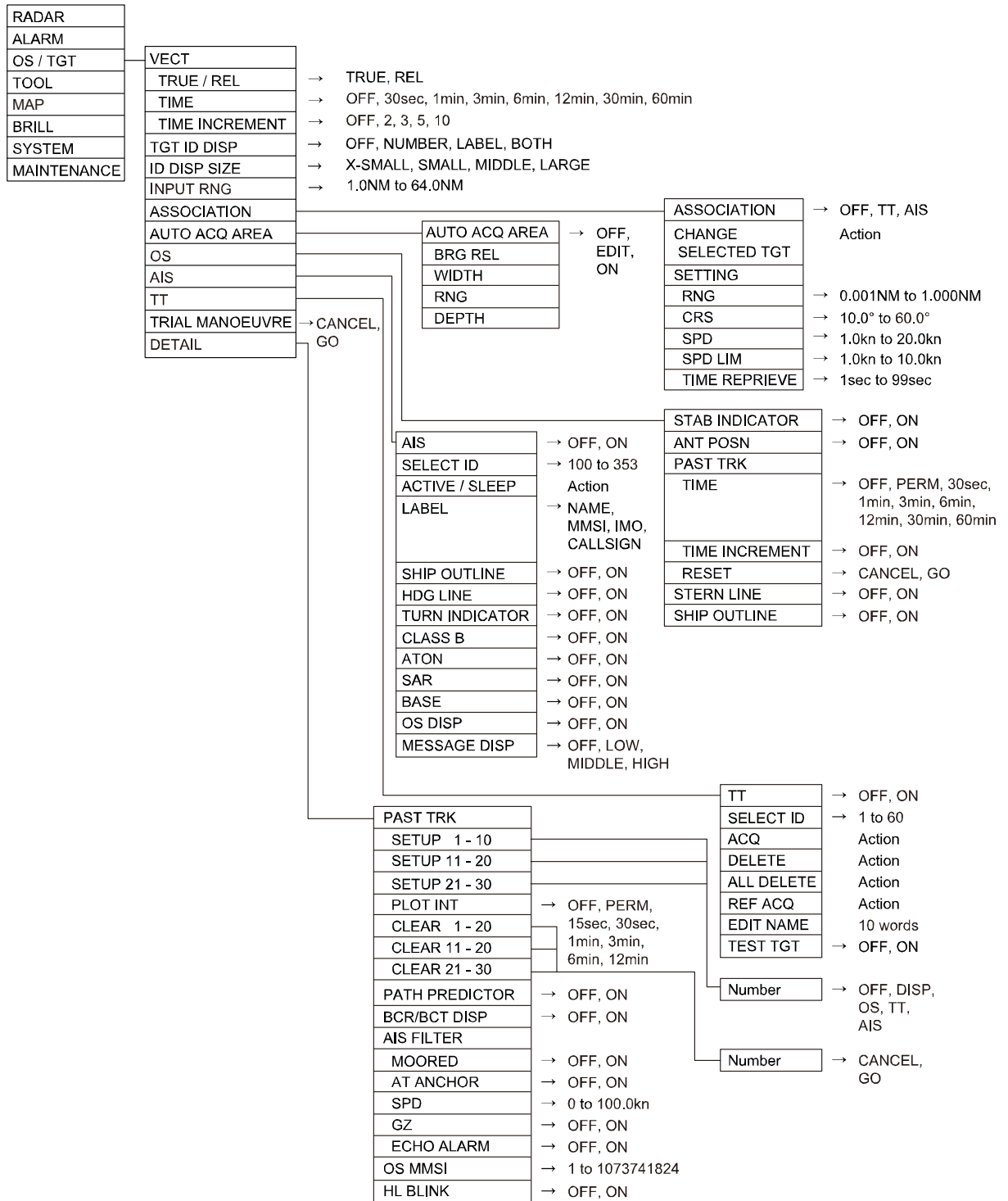

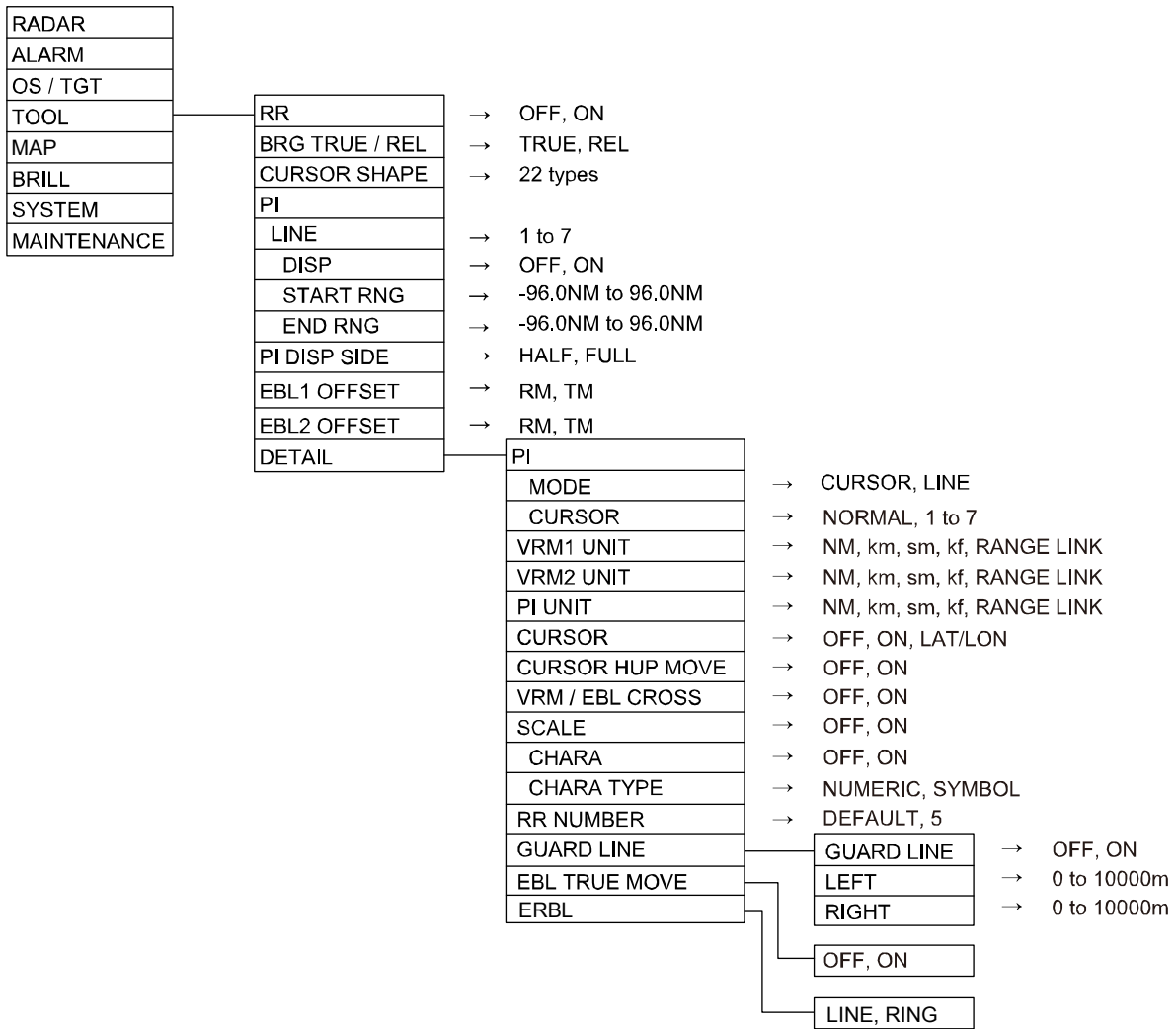

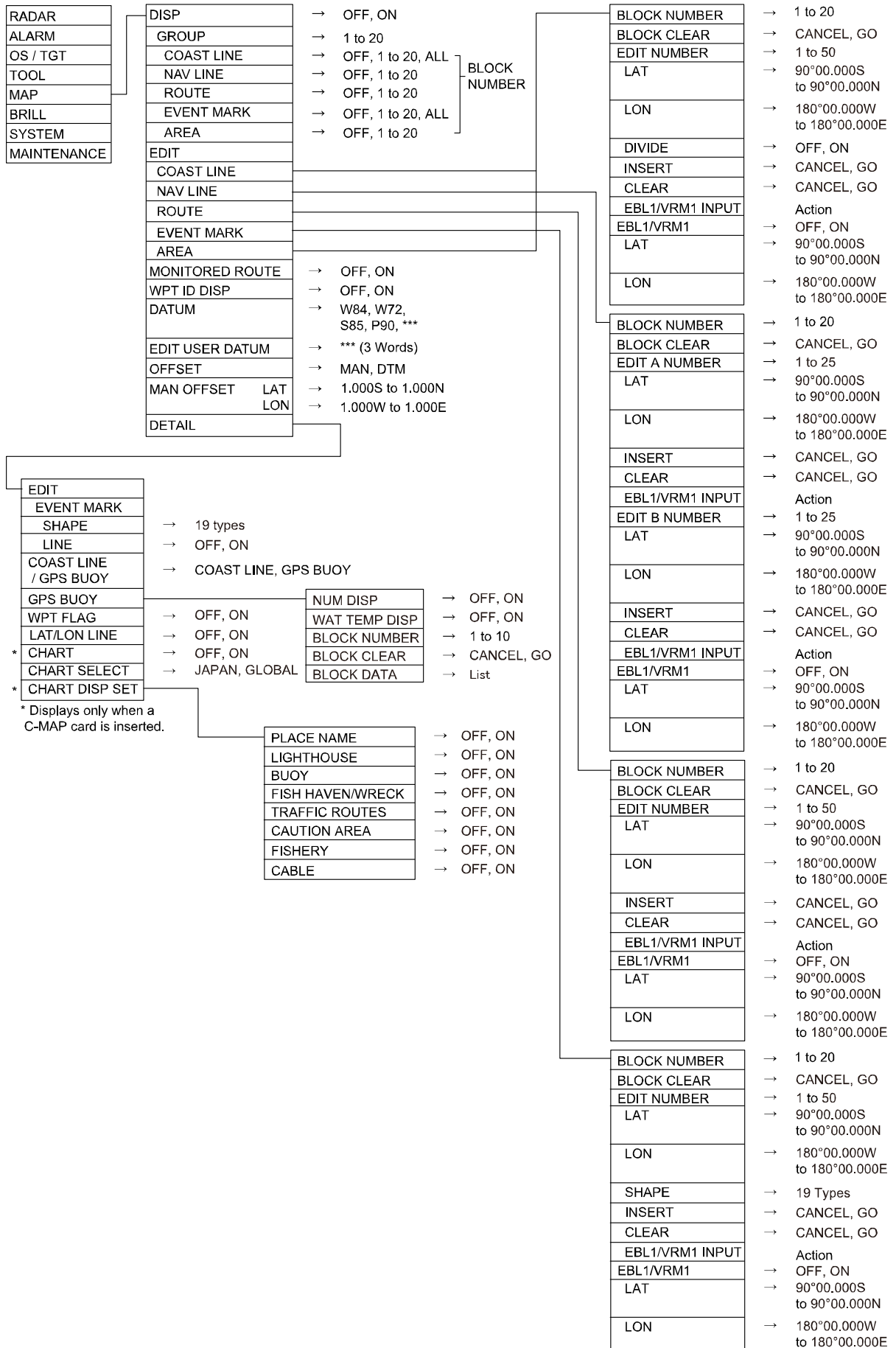



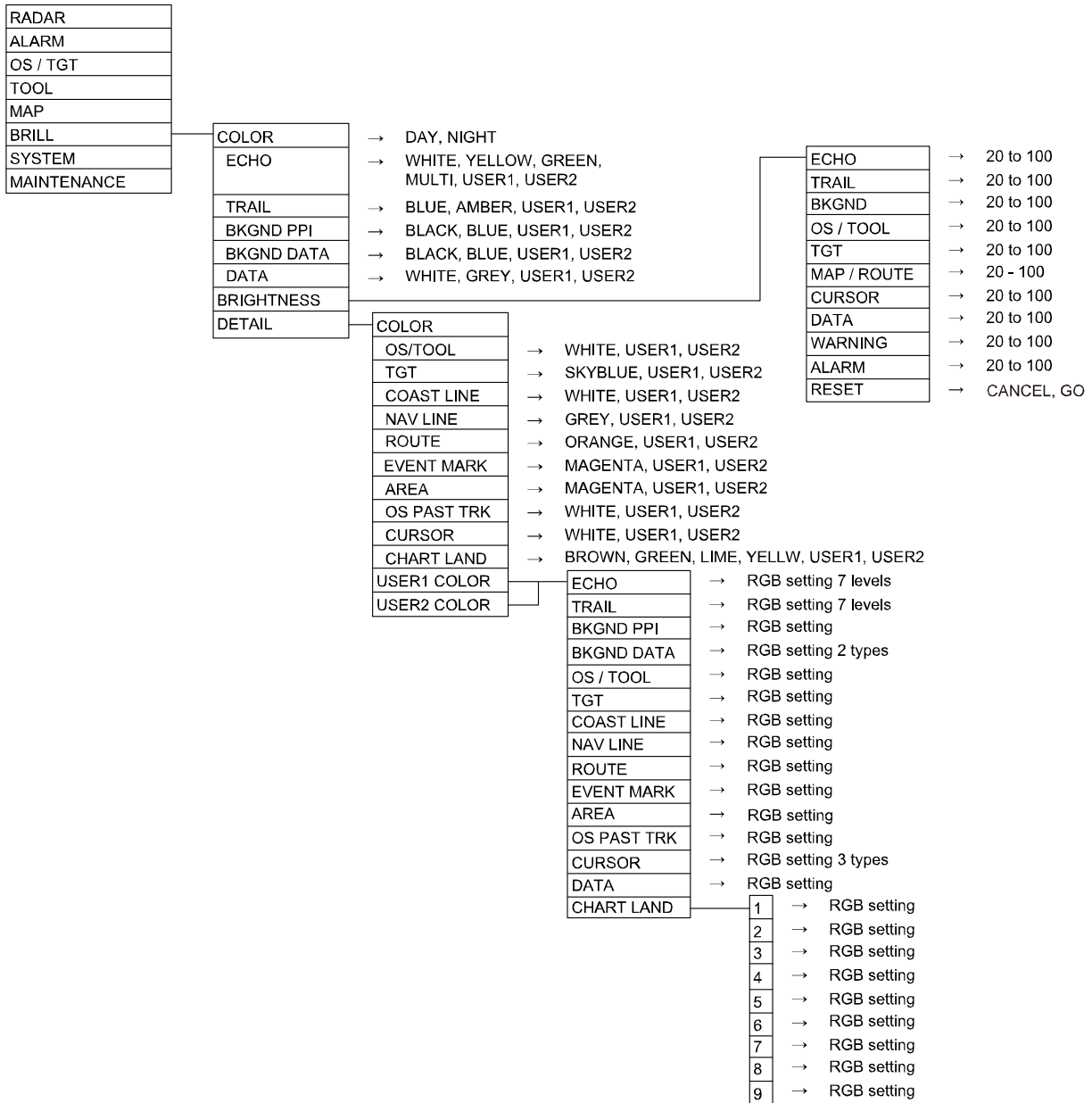

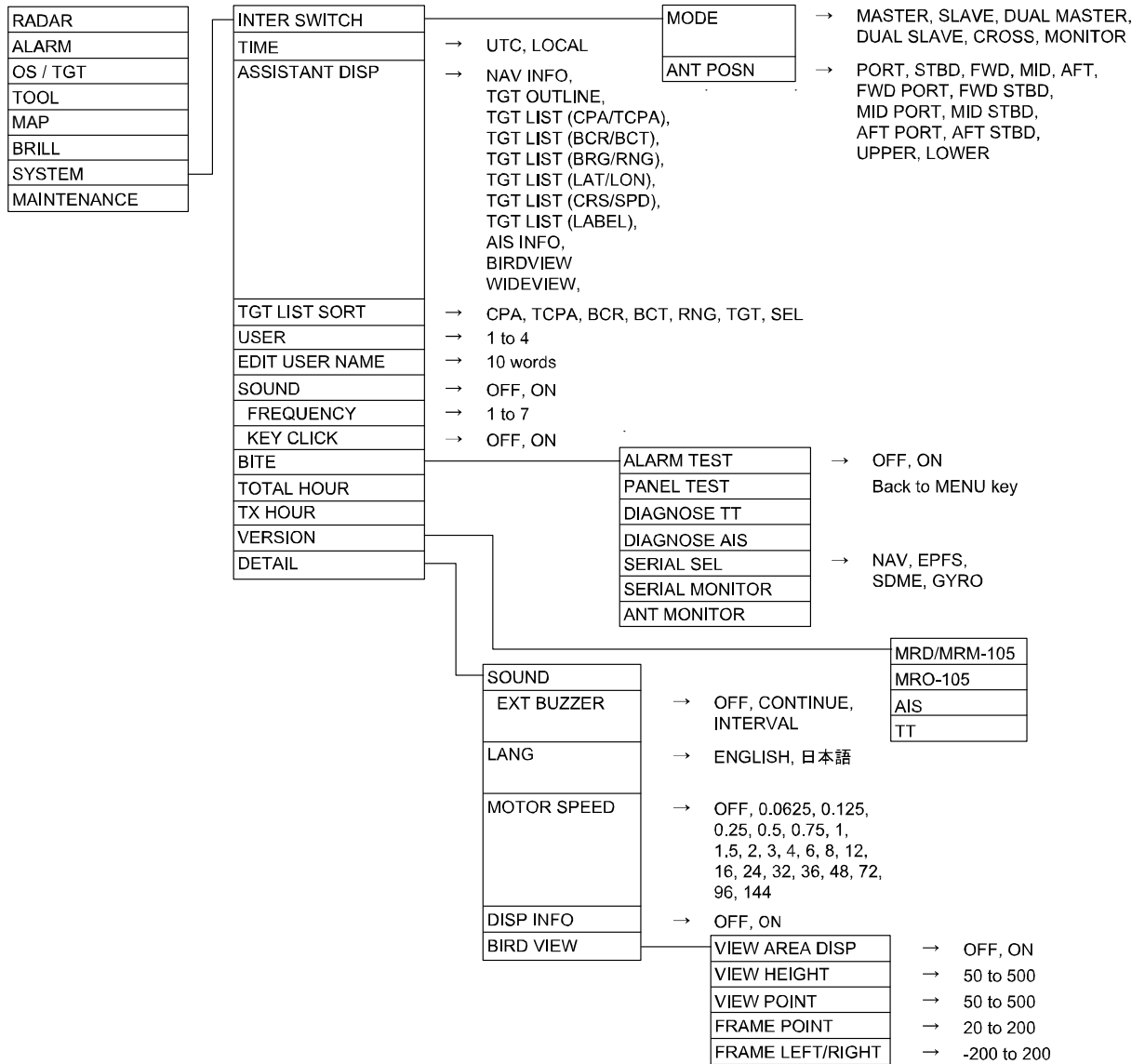

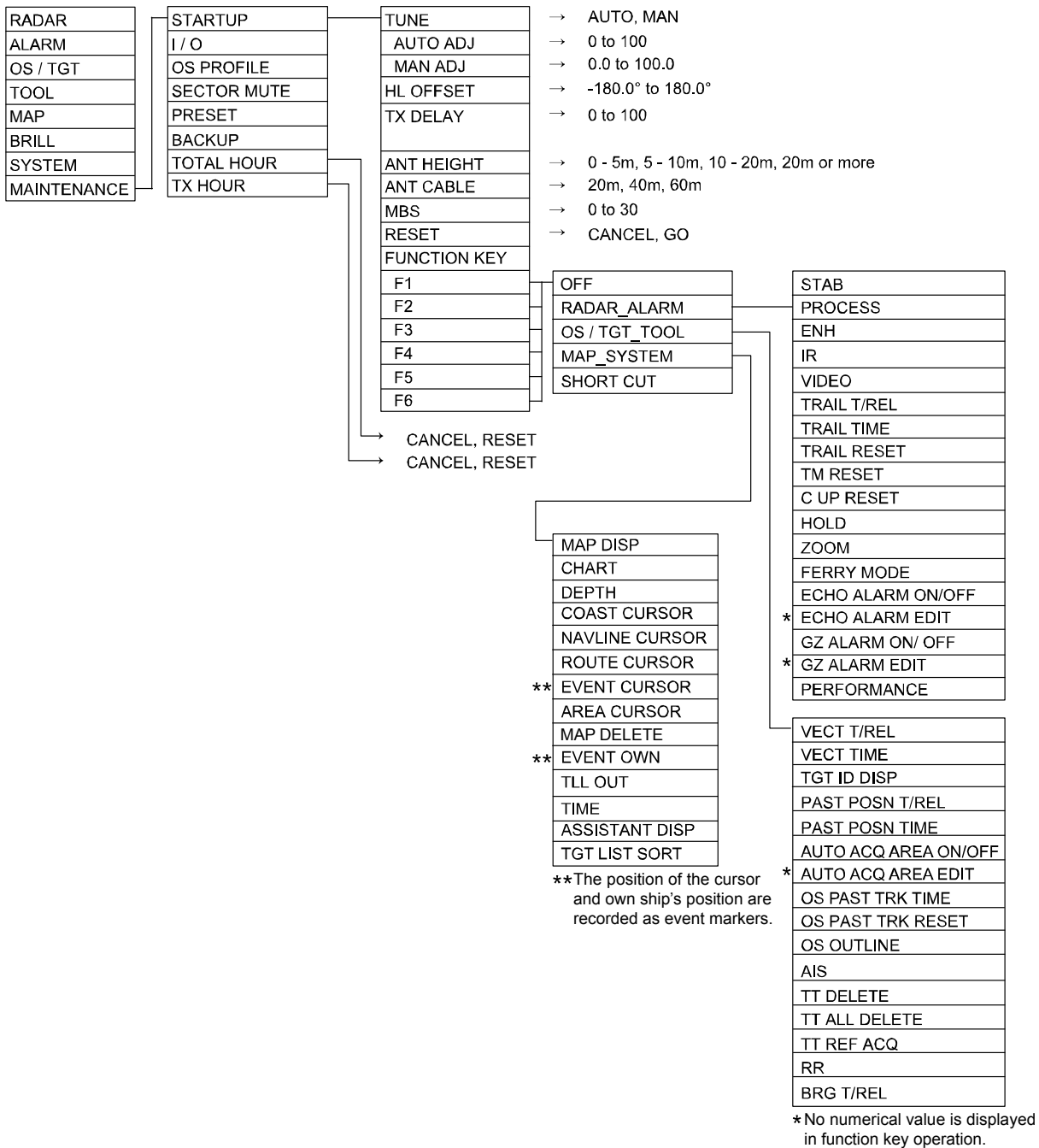

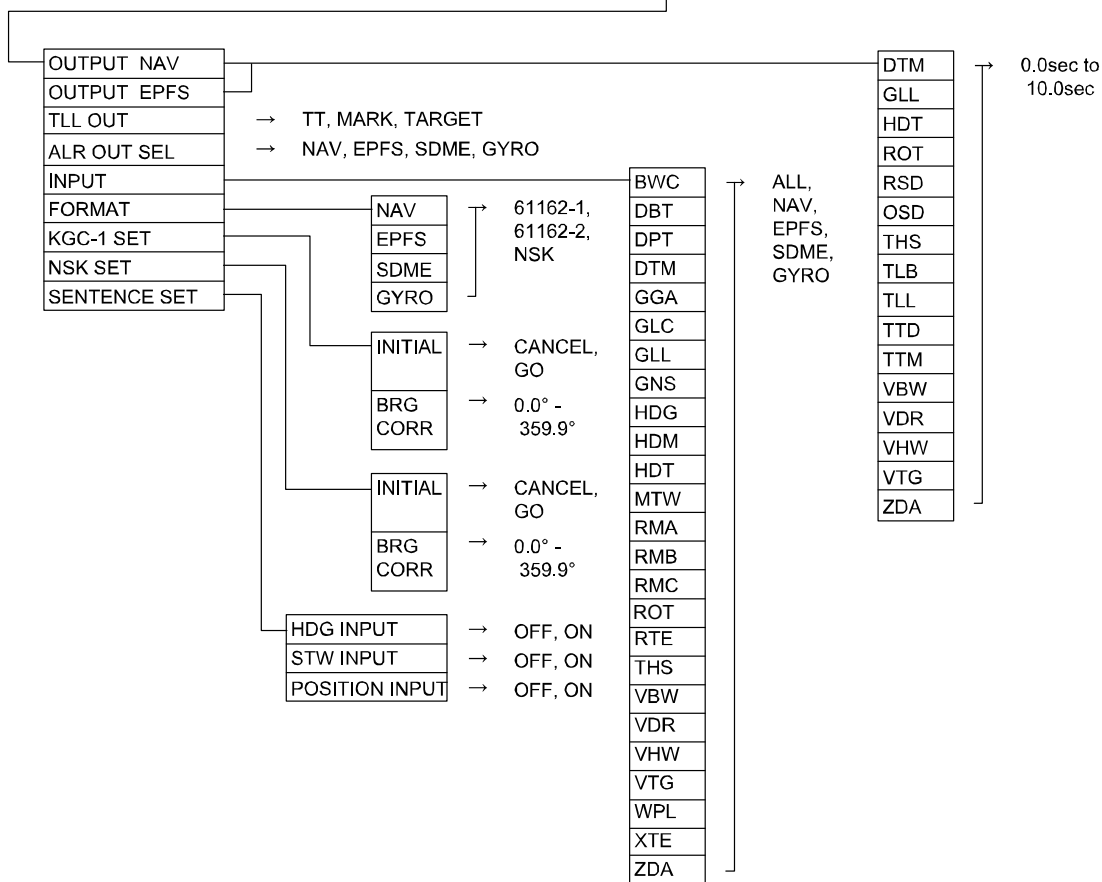
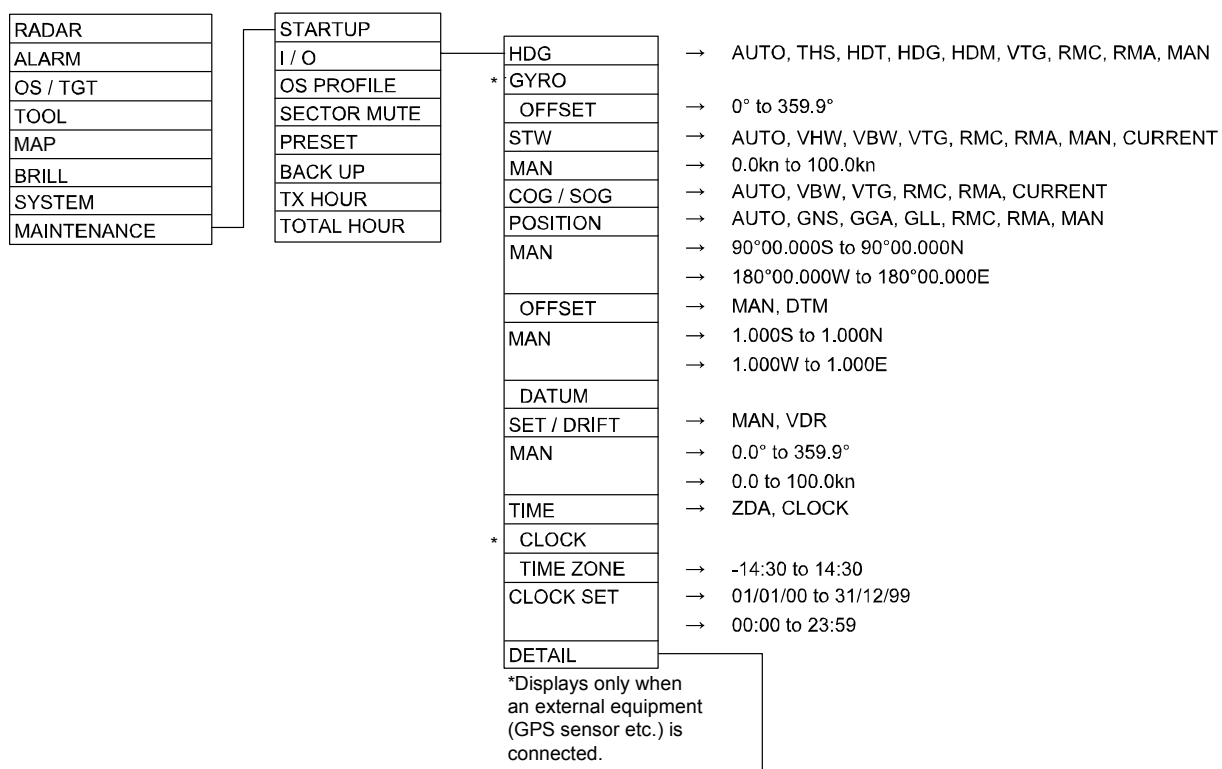

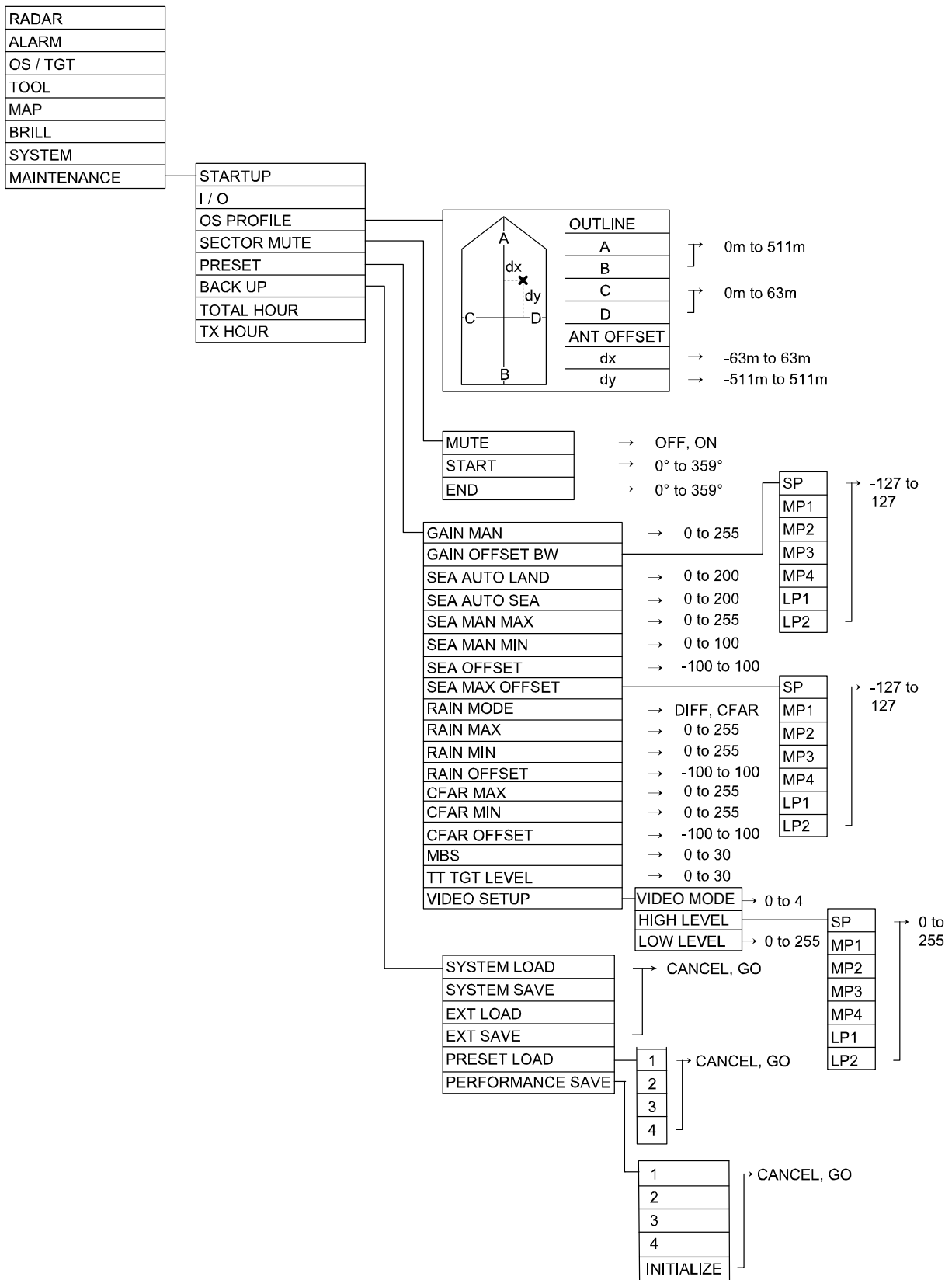

## Chapter 5 Specification

### 5.1 Antenna and Scanner

#### Antenna

Model name	RW701A-04	RW701A-06
Antenna length	4feet	6feet
Horizontal beam width	1.8°	1.2°
Vertical beam width	22°	22°
Polarization	Horizontal	

#### Scanner

Model name	RB717A	RB718A	RB719A
Type	Up-mast		
Antenna rotation rate	24 rpm or 48 rpm		
Transmitting Power	6kW	12 kW	25 kW
Water protection	IPX6		

## 5.2 Display unit and processor unit

Model name	MRD-105 (Display unit)	MRM-105 (Processor unit)
Display size and type	19 inch color LCD	---
Resolution	1280 X 1024 pixels	
Effective diameter	278 mm	---
Viewing distance	1 m	Refer to specification of display.
Frequency band	X-band 9410MHz $\pm$ 30MHz (9380MHz to 9440MHz)	
Speed class	Normal speed class (< 30 knot)	
Echo color	White/Green/Yellow/Multi/User1/User2	
Off centering	Up to 72%	
Range data accuracy	8 m or 1 % of range scale selected	
Range	0.125, 0.25, 0.5, 0.75, 1.5, 3, 6, 12, 24, 48, 96 NM  Up to 72 NM for transmit output 12 kW, Up to 96 NM for transmit output 25kW	
Display mode	Head up, North up, and Course up	
Other functions	CFAR (Clutter rejection), Interference rejection, Enhance, Process (Averaging), VRM, EBL, PI, ERBL, Cursor position (Lat/Lon), Bearing (true/relative), Trail (true/relative), Own ship past track, MAP (Event mark, etc), RGB Monitor output, VDR output, Inter switch	
NMEA Input/output	3 CH	
Power supply	21.6 VDC to 41.6 VDC MDC-2960 / MDC-2960BB: 130W or less (at 24VDC) MDC-2910 / MDC-2910BB: 150W or less (at 24VDC) MDC-2920 / MDC-2920BB: 200W or less (at 24VDC)	
AIS	254 targets	
TT (ARPA)	60 targets	
Temperature	-15°C to +55°C	
Water protection	No protection	

**5.3 External view and dimensions**

MRD-105

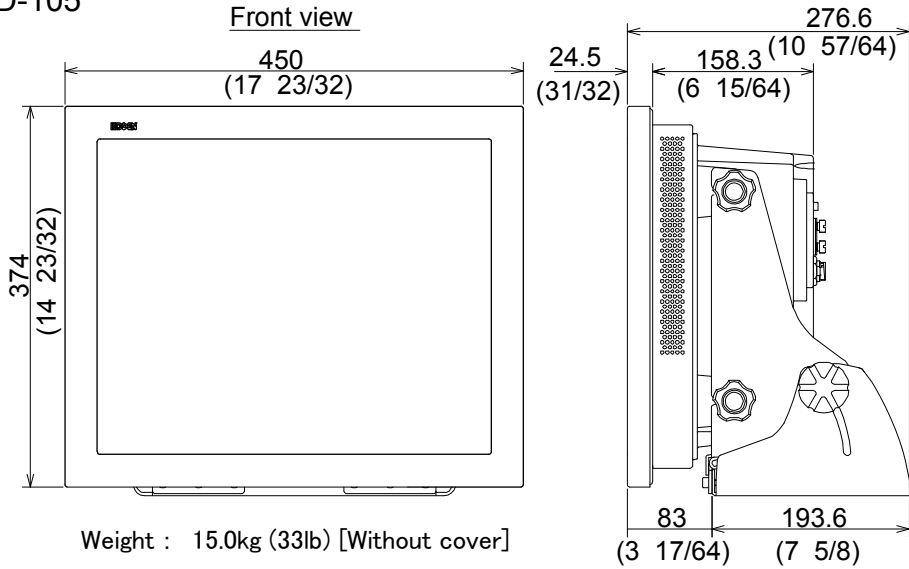

MRO-105

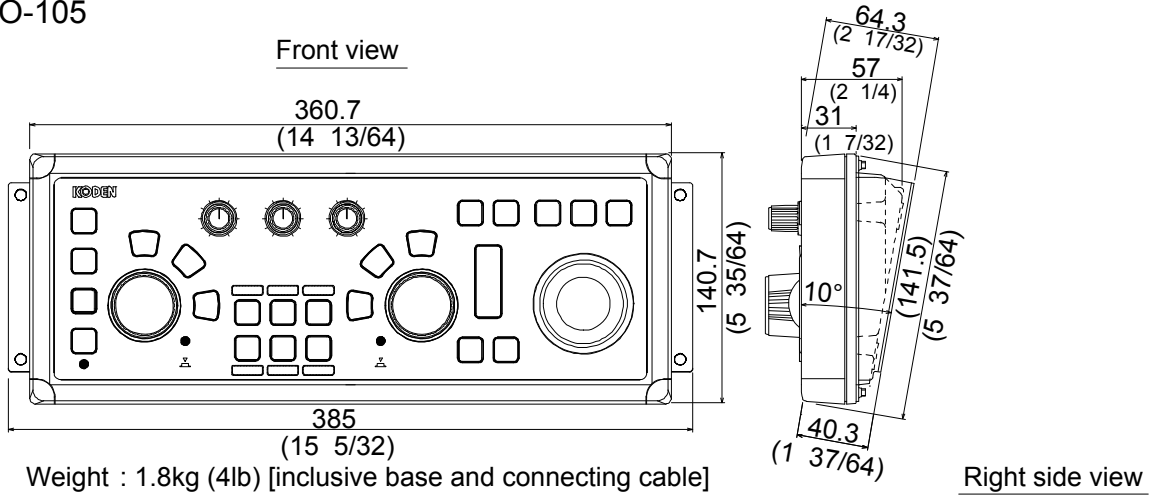

MRM-105

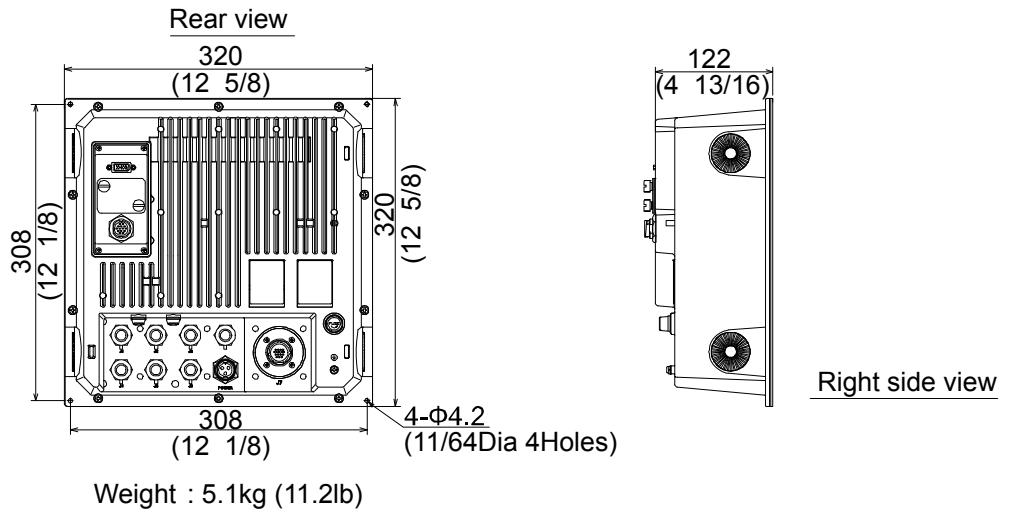



RB717A / RB718A

Unit: mm (inch)

4Feet: 1346(53)  
6Feet: 1970(77 9/16)

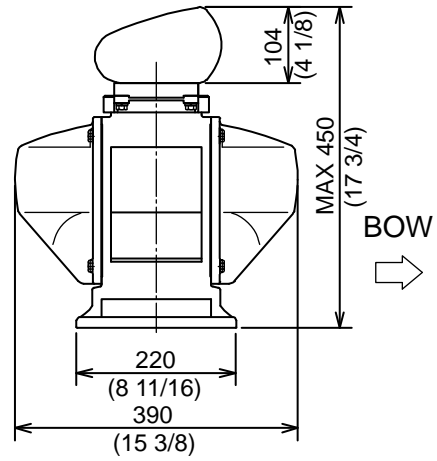
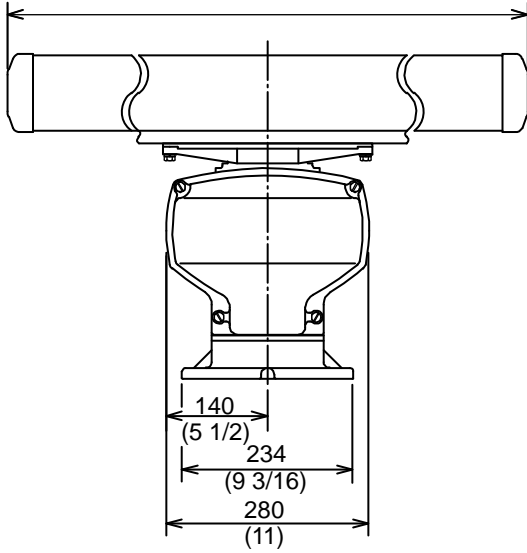

Weight : 23kg (51lb) [RW701A-04]  
25kg (56lb) [RW701A-06]

RB719A

4Feet: 1346(53)  
6Feet: 1970(77 9/16)

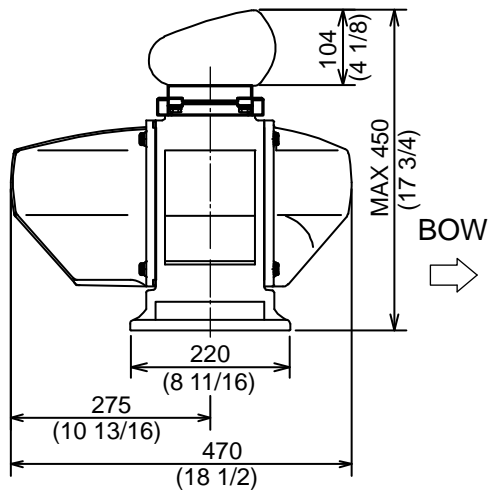
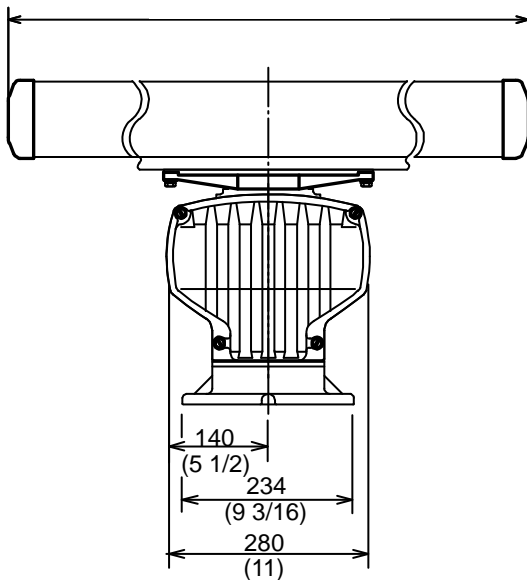

Weight : 27kg (60lb) [RW701A-04]  
29kg (64lb) [RW701A-06]

## Chapter 6 Principle of radar system

### 6.1 What is radar system?

The radar is a navigation device that transmits a very high frequency radio wave referred to as microwave from the antenna. The radar then receives the radio wave reflected by target(s) (e.g. other ship, buoy, island, etc.) via the same antenna and converts the received radio wave to electronic signals and sends these signals to the display unit. The radar makes it possible to find objects (targets), such as other ships, rocks or coastline, not seen by eyesight at night or in fog and allows ships to avoid these potential hazards. As the antenna transmits during 360-degree rotation, it is possible to see the current surrounding situation around your ship at a glance.

The microwave radiated from the radar is referred to as pulse wave and the transmitting and receiving of these waves is alternated. Up to thousands of pulse waves are transmitted and received during one rotation

The typical radar antenna is of parabolic type or slotted array type and its performance is essential for good radar performance. Some of factors affecting the quality of the target returns are antenna beam width and side lobe level. The narrow beam width provides high resolution for angular orientation to distinguish objects and the low side lobe level reduces false image effect.

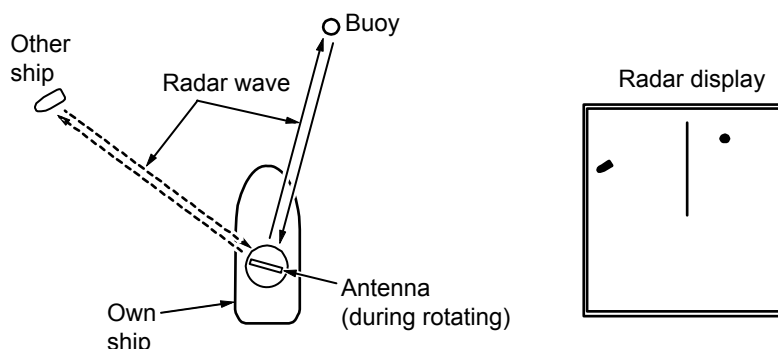

### Side lobe

The main lobe means the strongest radiated beam sent from the specific antenna, and the other weaker beams, are referred to as a side lobes. A side lobe level is a difference between the largest side lobe level and main lobe level.

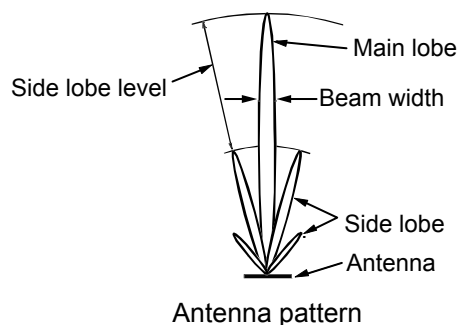

**Beam width**

Antenna beam width is defined as the angle where the radiation power density is within a half of maximum power density (-3 dB) in main lobe (also, referred to as “half value width”).

**6.2 Characteristics of radar radio wave**

The radar radio wave propagates slightly along the ground (primarily line of sight). This characteristic varies depending on density of atmosphere, but is generally calculated according to the formula as shown below, considering that the distance with radar sight D is about 6 % longer than the distance with optical sight.

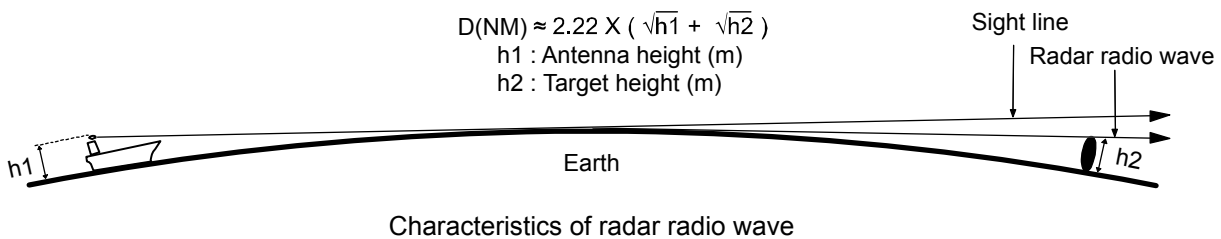

**Target hardness reflected**

The strength of the reflected wave from a target varies depending on not only the distance from the target, its height or size, but also its material and features. A target with a low degree of reflection or low incident angle, such as FRP (Fiber Reinforced Plastic) and wooden ship is not reflected well. Therefore, care shall be taken that a FRP ship, a wooden ship or an object such as sand, a sandbar and muddy cay are poor radar targets.

Since the distance from the coastline, etc. to your ship on a radar image tends to be seen as longer than that from the actual coastline, more caution should be paid when navigating around such objects.

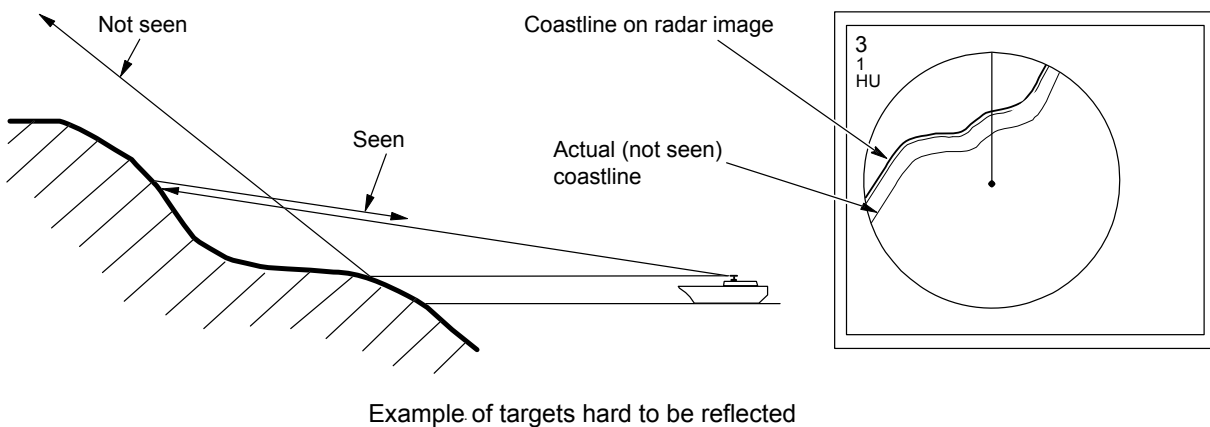

## Radar shadow

Since radar radio wave is line of sight in nature your stack mast close to the antenna or, a large ship or mountain may create blind spots for which the radar cannot penetrate. In such cases, they may completely or partially hide targets and cast a long shadow.

Since the shadow of your stack or mast is known at the time of installation, proper selection of the antenna location is necessary to reduce the shadow effect. Since targets in this shadow area is less likely to be seen than in open sea, extra attention should be paid in shadowed areas.

## False image

An image that does not actually exist (false image) at sea may appear on the display.

The phenomena that causes false echoes are categorized and be described as follows:

- Virtual image

The image of a large physical object in proximity may appear in two different orientations. One is a real image and the other is a false image caused by wave re-reflected by the stack or the mast, etc. On the display, one image appears at the correct distance and bearing, and another one appears in the direction of a stack, a mast, etc. These images may also be generated by re-reflection from bridges and quays too.

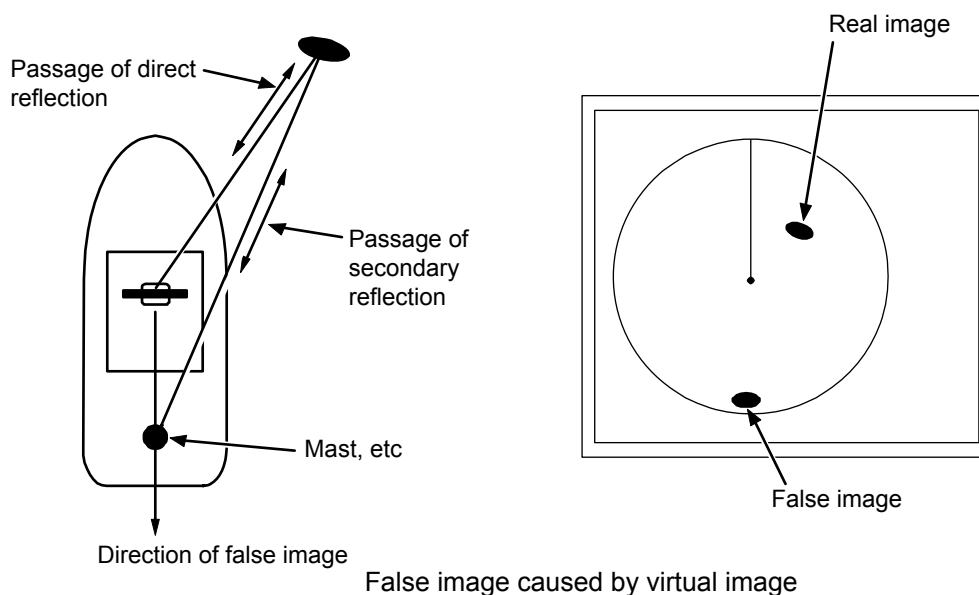

• Duplicate target images

When there is a big reflective surface nearby and it is perpendicular at a close distance (i.e. when your ship is passed by a big ship, etc.), the radio wave bounces between own ship and the other ship. Therefore, two to four images may appear at equal range in the direction of this target. The false images generated by this multi-path reflection are referred to as “double targets”. In this case, the closest target is the real image.

If the distance and bearing between own ship and the reflective target changes, then the duplicate targets will disappear. Therefore, this false image can be easily distinguished.

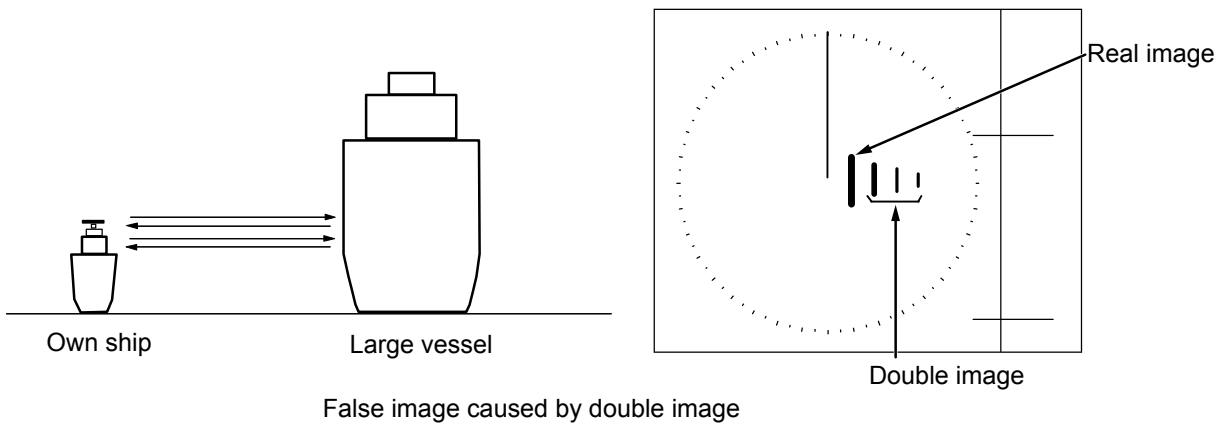

Side lobe images

The microwave beam radiated from the antenna has a side lobe in different direction than that of the main beam. Since this side lobe level is lower than that of main beam, the effect is negligible for targets at long range, but a close, strong reflecting target may cause false image appearing in a circular arc shape.

 <p style="font-size: 24px; font-weight: bold; margin: 0;">CAUTION</p>	<p>When own ship is close to large targets such as land, a circular image may appear.</p>
---	---

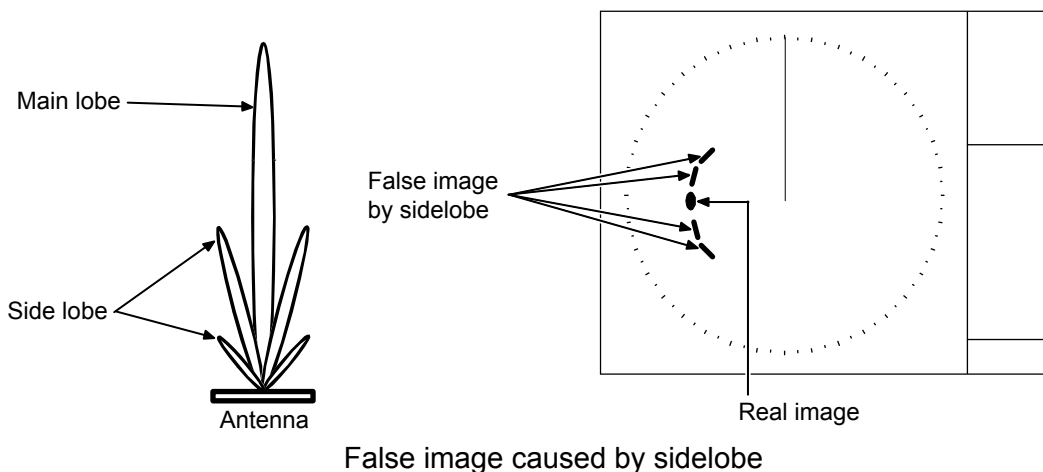

- Skip target images

False image of a distant target caused by “skip” phenomenon

Depending on weather conditions, skip caused by the temperature inversion layer of air, etc. may appear. In this case, the radio wave may unusually propagate to distant targets out of the radar range. A target at more than the maximum range may appear as an image, and may be displayed as a false image with closer distance than the actual one. This phenomenon is a result of the wide range echo delay time exceeding the transmission period, and is displayed as echo in the following rotation. If the range scale is changed and the target range is changed, it can be judged as a false image.

### 6.3 Radar interference

When the radar with the same frequency band is used nearby, interference noise appears on a display.

Although appearance of interference is not constant, the shape is almost always swirling or radial.

This series of radars features an IR (interference rejection) facility to reduce this interference.

## 6.4 Receiving the Radar Beacons, SART and Radar Enhancer

The X-band radar system is required to be capable of receiving signals emitted from a Radar Beacon, SART (Search and Rescue Transponder) and Radar enhancer. To receive those signals by the radar system, use the following procedures.

- 1 Set the range scale to 6 or 12 NM.
- 2 Select Radar => IR menu and turn off the Interference Rejection function.  
 Refer to “**Interference rejection (IR)**” (page3-7)
- 3 In case the radar picture is obscured with too many echo signals, detune the receiver a little for better observation.
- 4 When own ship approaches the transmitting Radar Beacon or the SART, the echoes will become blurred in an arc. For better observation of those signals, adjust the Gain, Anti-clutter Sea and RAIN controls, as appropriate.

The enhancer yields larger echo reflection than normal one.

### About SART

According to the GMDSS (Global Maritime Distress and Safety Systems) requirement, the IMO/SOLAS class ships must be equipped with a SART. When a ship is in distress, a signal will be automatically emitted from the SART so that other ships and/or aircrafts can identify its location. When your ship equipped with a X-band radar comes within 8 NM of a ship in distress, the SART picks up the radar signal and responds to it. The signal consists of 12 sweeps and is emitted in the frequency range of 9.2 GHz through to 9.5 GHz. The SART has two sweep times that switch from slow sweep (7.5  $\mu$ s) to fast sweep (0.4  $\mu$ s) and vice versa, according to the distance. When the radar receives this signal, a line of 12 dots, which is equally spaced at about 0.64 NM, appears on the screen. The nearest blip of the SART indicates the location of the ship in distress. When your vessel comes within 1 NM to the SART, a fast sweep signal is displayed on the radar and a thin line connects the 12 blips.

**Actual location of the ship carrying the SART**

If your ship is located at 1 NM or more away from the SART, the position at which the first echo is displayed is 0.64 NM behind the actual SART position when the 12 SART echoes are identified. If your ship comes within 1 NM from the SART, the fast sweep signal is indicated. The position of this echo is displayed 150 m beyond the actual SART position.

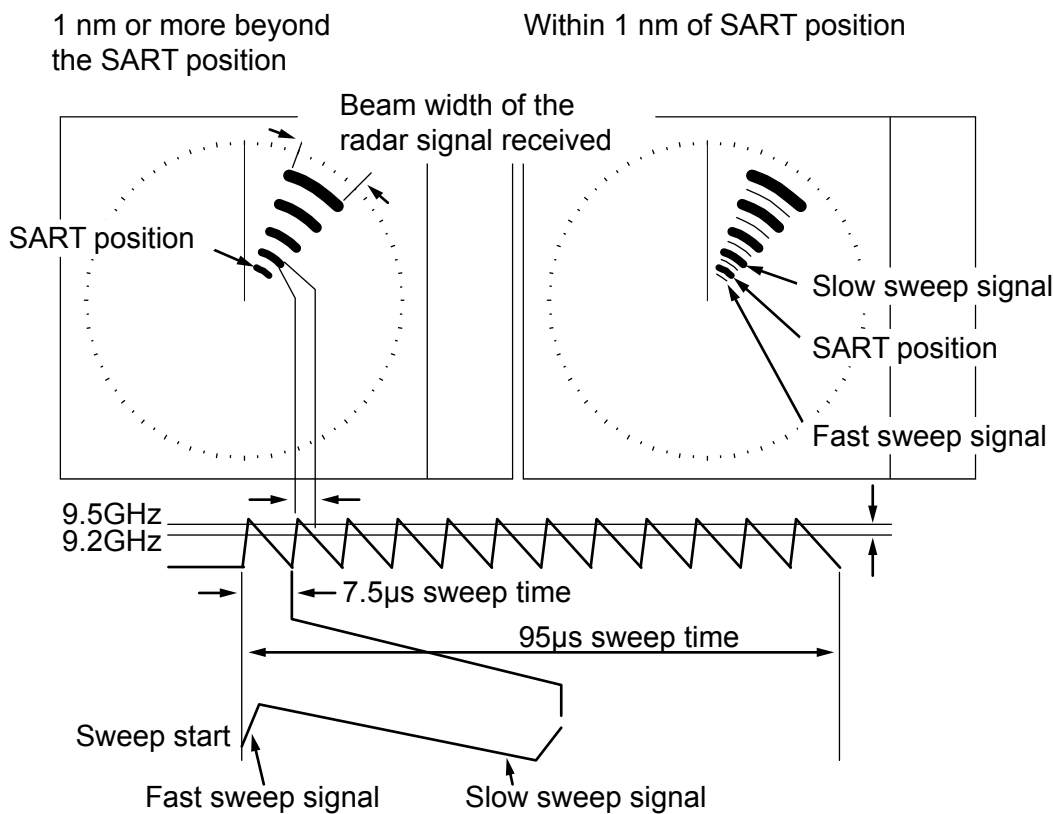

The SART signal presentation and its signal timing



## Chapter 7 Simple fault diagnostics

These items show simple fault diagnostics procedures.

For the phenomena listed below, refer to the installation manual.

Items posted

- 7.1 No alarm sound. (ALARM TEST)
- 7.2 Operation unit (panel) key is not operational. (PANEL TEST)
- 7.3 TT (ARPA) is not operational. (DIAGNOSE TT)
- 7.4 AIS is not displayed. (DIAGNOSE AIS)
- 7.5 Need to confirm serial input. (SERIAL MONITOR)
- 7.6 No video display. (ANT MONITOR)
- 7.7 Screen is frozen.

**1** Press [MENU] key to display "Menu".

Select [SYSTEM] => [BITE].

7.1	ALARM TEST
7.2	PANEL TEST
7.3	DIAGNOSE TT
7.4	DIAGNOSE AIS
7.5	SERIAL SEL
	SERIAL MONITOR
7.6	ANT MONITOR

## 7.1 No alarm sound (ALARM TEST)

This procedure is applied in the case of no alarm sound.

At the beginning, select [SYSTEM] => [SOUND] and confirm that the status is [ON].

- 1** Press [MENU] key to display "Menu".  
Select [SYSTEM] => [BITE] => [ALARM TEST] => [ON], and then press [ENT] key after selection.
- 2** HDG, CTW and STW value at the upper right of the screen turns to 0 and color changes to red.  
Alarm sounds and alarm display appears at the lower right of the screen.  
Alarms displayed are [HDG is unavailable], [SPD is unavailable].
- 3** Confirmation is completed if alarm sounded.
- 4** [ALARM TEST] automatically returns to [OFF] state after 10 seconds from turning [ON] state.

If no alarm sounds while alarm display has appeared, then the operation unit (panel) is deemed to be not operational.

 Refer to "**Operation unit (panel) key is not operationa**" (page7-3)

## 7.2 Operation unit (panel) key is not operational (PANEL TEST)

This procedure is applied when the function does not become effective despite the key being pressed. At the beginning, confirm the connecting cables of Operation unit (panel) and the connection of display unit.

- 1 Press [MENU] key to display "Menu".  
Select [SYSTEM] => [BITE] => [PANEL TEST] =>.
- 2 Panel illustration will appear on the screen.
- 3 Press any key.  
[●] mark will appear at the left side of key name during the key is pressed.  
The line in the circle will rotate when the knob is turned.  
The circle color will be reversed when the knob is pressed.  
The small circle in the square will move when track ball is moved.

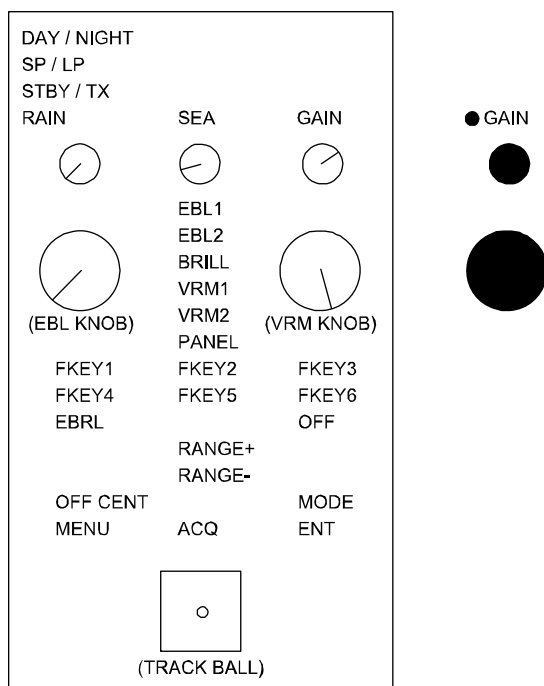

- 4 Pressing [MENU] key will complete test.

Operation unit (panel) is deemed to be in malfunction, if No.3 item is not normally displayed.

### 7.3 TT (ARPA) is not operational (DIAGNOSE TT)

This procedure is applied when acquisition operation does not start despite [ACQ] key being pressed.

At the beginning, confirm it [INPUT RNG] is properly set.

The targets outside of [INPUT RNG] will not be acquired.

 Refer to “**INPUT RNG: Input range**” (page3-21)

ATA Board dedicated for TT (ARPA) processing is installed in the Display unit.

This procedure confirms ATA Board function.

- 1 Press [MENU] key to display “Menu”.  
Select [SYSTEM] => [BITE] => [DIAGNOSE TT] =>.
- 2 Confirm [o] mark is appeared on the left side of [TT BOARD], [HDG].
- 3 Turn track ball to left to complete.

If [x] mark is displayed in step 2, then

In the case of [TT BOARD]: ATA board is in malfunction.

In the case of [HDG]: Valid HDG is not input to ATA board.

Confirm HDG input for Display unit.

 Refer to “**Need to confirm serial input**” (page7-6)

HDG is usually input to the GYRO connector.

## 7.4 No AIS display (DIAGNOSE AIS)

This procedure is applied when AIS is not displayed.

At the beginning, confirm it [INPUT RNG] is properly set.

Targets outside of [INPUT RNG] are not displayed.

 Refer to “**INPUT RNG: Input range**” (page3-21)

AIS Board dedicated for AIS processing is installed in the Display unit.

Confirm AIS board function by following steps.

- 1 Press [MENU] key to display “Menu”.  
Select [SYSTEM] => [BITE] => [DIAGNOSE AIS] =>.
- 2 Confirm that the [o] mark appears at the left side of [AIS BOARD], [AIS DATA], [HDG], [SPD], [LAT/LON] and [COG/SOG].
- 3 Turn trackball to the left to complete.

If [x] mark is displayed in step 2, then

In the case of [AIS BOARD]: AIS Board is in malfunction.

In the case of [AIS DATA]: No valid AIS data input to AIS Board.

Confirm AIS receiver connected to Display unit.

AIS DATA is usually input to AIS (J2) connector.

In the case of [HDG]: No valid HDG input to AIS Board.

Confirm HDG input of Display unit.

 Refer to “**Need to confirm serial input**” (page7-6)

HDG is usually input to GYRO connector.

In the case of [SPD]: No valid SPD input to AIS Board

Confirm SPD input of Display unit.

 Refer to “**Need to confirm serial input**” (page7-6)

SPD is usually input to SDME (J6) connector.

In the case of [LAT/LON]: No valid LAT/LON input to AIS Board.

Confirm LAT/LON input of Display unit.

 Refer to “**Need to confirm serial input**” (page7-6)

LAT/LON is usually input to EPFS (J5) connector.

In the case of [COG/SOG]: No valid COG/SOG input to AIS Board.

Confirm COG/SOG input of Display unit.

 Refer to “**Need to confirm serial input**” (page7-6)

COG/SOG is usually input to SDME (J6) or EPFS (J5) connector.

## 7.5 Need to confirm serial input (SERIAL MONITOR)

This procedure is applied to confirm serial input of Display unit.

Serial input of connectors can be confirmed with the following 4 connectors:

GYRO, NAV (J4), EPFS (J5), SDME (J6).

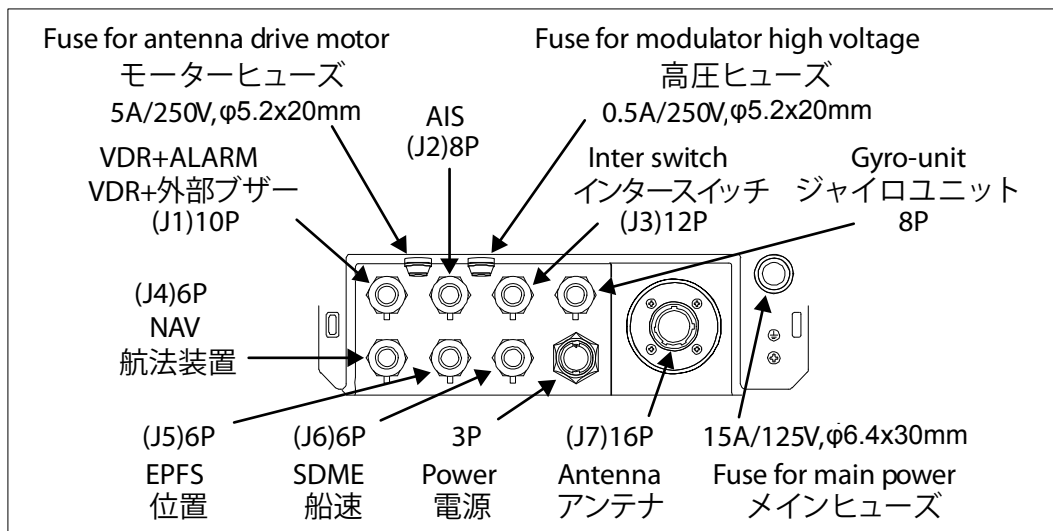

- 1 Press [MENU] key to display "Menu".  
Select [SYSTEM] => [BITE] => [SERIAL SEL] => then press [Enter] after selection.
- 2 Select [SERIAL MONITOR] =>.
- 3 Input data will be displayed.  
As the data is input continuously, display continues to move according to data.  
By pressing [Enter] key, data display will stop temporarily to confirm data content.
- 4 Turn track ball to left to complete.

Data confirming item in step 3

In the case that data is not displayed: Confirm input data device connected to Display unit.

In the case that data is displayed but is garbled: Confirm baud rate.

☞ Refer to "**FORMAT**" (page4-47)

In the case that data is displayed correctly: Confirm data format.

☞ Refer to "**Low or doubtful integrity information display**" (page4-47)

## 7.6 No video display (ANT MONITOR)

This procedure is applied when no video is displayed in the screen.

- 1** Press [MENU] key to display "Menu".  
Select [SYSTEM] => [BITE] => [ANT MONITOR] =>.
- 2** Antenna status will be displayed.
- 3** Turn track ball to left to complete.

Antenna status criteria in step 2

HIGH VOLTAGE: If the value is other than 133 to 155, then it means malfunction of high voltage.

MAG CURRENT: If the value is other than 15 to 127, then it is malfunction of magnetron.

MAG HEATER: If the value is other than 46 to 94, then it means malfunction of magnetron.

TUNE VOLTAGE: If the value is other than 99 to 447, then it means malfunction of magnetron or Front end module.

## 7.7 Screen is frozen

This is the confirming procedure when screen is frozen.

Frozen screen means the cases of no video updating or no cursor movement.

As the radar system is an indispensable device for safety navigation, it is very dangerous without correct display.

- 1** Turn Gain knob, Sea knob and Rain knob to confirm changes of video.
- 2** Turn track ball to confirm if cursor is moving.  
While Menu is displayed, confirm if selection item is moving.

When malfunction of either step 1 or step 2 is found, the screen is frozen.

Restart Display unit immediately.



## 7.8 About alarms

If any malfunction or operation error has been detected in the radar, or if the external device gives the ALR sentence input, then alarms and warnings shown below appear at the lower right of the screen.

If two or more alarms occur at the same time, then it is possible to confirm all the alarms in [LIST].

☞ Refer to “LIST” (page4-8)

Alarms occurred since Power ON can be confirmed by [HISTORY LIST].

☞ Refer to “HISTORY LIST” (page4-8)

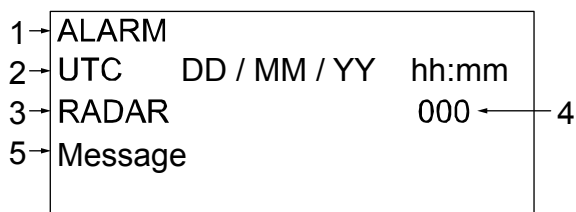

### 1 [ALARM] or [WARNING].

ALARM: Indicates by red letters.

Makes alarm sound.

Includes alarms by radar and by external devices. \*

Continues alarm indication and sound until acknowledgement by pressing [OFF] key. \*\*

Provides alarm output. \*\*\*

WARNING: Indicates by yellow letters.

Makes alarm sound.

Only by radar itself.

Goes out after 5 seconds.

Does not give alarm output.

### 2 Time occurrence.

### 3 Indication of alarm source. \*\*\*\*

RADAR: Radar in operation.

AIS: External device connected to AIS connector.

NAV: External device connected to NAV connector.

EPFS: External device connected to EPFS connector.

SDME: External device connected to SDME connector.

GYRO: External device connected to GYRO connector.

### 4 Number.

If an alarm is generated by this radar, then it shows the alarm number in “Alarm list” (page7-11).

If an alarm is input from an external device, then it shows the number in ALR sentence.\*

### 5 Message.

If an alarm is generated by this radar, then it shows the alarm message in “Alarm list” (page7-11).

If an alarm is input from an external device, then it shows the message in ALR sentence. \*

\* In case of alarm caused by an external device, alarm is activated by ALR sentence input from the external device.

\*\* In case of alarm caused by an external device, ACK sentence is sent out onetime only from the connector ALR sentence is inputted.

\*\*\* Alarm contact closed in case of failure.

While [Alarm] exists, connection between pin 9 and pin 10 of J1 (VDR + external buzzer) becomes short from open-circuit.

\*\*\*\* Indication priority order can be set for alarms made simultaneously by multiple devices.

 Refer to "**PRIORITY**" (page4-7)

## Alarm list

List of system alarm and message.

Alarm number	Alarm message	
TT (ARPA) alarms		
1	Tracked target is lost. Ref tracked target is lost.	Refer to page3-24
2	Tracked target exceeded the CPA/TCPA limit.	Refer to page3-15
3	Tracked target entered into the guard zone.	Refer to page3-23
4	Auto acquisition of a radar target.	Refer to page3-22
11	Tracked target interface not connected.	Refer to page7-3
60	Tracked target exceeded the limit.	Refer to page3-24
AIS alarms		
5	AIS target is lost.	Refer to page3-38
6	AIS target exceeded the CPA/TCPA limit.	Refer to page3-15
7	AIS target entered into the guard zone.	Refer to page3-23
8	Auto activation of a AIS target.	Refer to page3-22, 3-39
9	Activated AIS target without HDG or COG.	
61	AIS target exceeded the limit.	Refer to page3-38
69	AIS interface not connected.	Refer to page7-5
70	AIS alarm signal.	Refer to installation manual. 7.4.3 Serial data input/output specification (AIS)
71	AIS no OS COG/SOG data.	Indicates when own ship ground bearing or speed is not available, although it is required for AIS function.
72	AIS no data.	Refer to page3-38
75	Received AIS message	Refer to page4-9
77	AIS No WGS84 DATUM	Refer to page3-38

Alarm number	Alarm message	
<b>Sensor alarms</b>		
14	Change to relative bearing.	Refer to page7-6
15	Change to relative vector.	
16	Change to relative past position.	
17	Change to relative trails.	
18	Change to head up.	
19	Change EBL origin position.	
20	HDG is unavailable.	
21	SPD is unavailable.	
22	SET/DRIFT data is unavailable.	
23	LAT/LON data is unavailable.	
24	DATUM data is unavailable.	
25	Time data is unavailable.	
27	Change to sea stabilization.	
<b>Antenna alarms</b>		
49	Antenna not connected.	Refer to page7-7
50	Antenna magnetron current abnormal.	
51	Antenna magnetron heater abnormal.	
52	Antenna magnetron high voltage abnormal.	
54	Azimuth abnormal.	
55	Head line signal abnormal.	
56	Trigger abnormal.	
57	Radar video abnormal.	
<b>Other alarms</b>		
10	Panel not connected.	Refer to page7-3
12	Navline Exceeded.	Refer to page4-7
13	Echo map area alarm detected.	Refer to page4-6
30	External loading error.	Refer to page1-10
31	External saving error.	
32	Illegal data of loading.	
33	Flash memory error.	
53	Interswitch not connected.	Refer to page4-37
59	Echo area alarm detected.	Refer to page3-13
76	Change to reference antenna.	Refer to page 1-5

## Warning list

List of system warning and message.

Warning number	Warning message	
TT (ARPA) warnings		
95	Tracked target full.	Refer to page3-24
96	Tracked target no data.	Indicates when there is no tracked target to erase.
97	Tracked target out of range	Refer to page3-21
110	Tracked target overload.	Refer to page3-24
111	Tracking malfunction. REL CRS	Refer to page3-28
112	Tracking malfunction. REL SPD	
113	Tracking malfunction. CPA	
114	Tracking malfunction. TCPA	
115	Tracking malfunction. T CRS	
116	Tracking malfunction. T SPD	
120	Reference target overload.	Refer to page3-26
Other warnings		
99	Pre heating.	Refer to page2-4
104	No Zoom area or minimum range.	Refer to page4-2
105	Map data full.	Refer to page 4-25
106	Interswitch changed the mode.	Refer to page 4-37
108	No offcenter.	Refer to page 2-22
109	AIS target overload.	Refer to page 3-38

## Chapter 8 Index

### A

AIS.....	3-38
AIS symbol .....	3-40
Alarm list.....	7-11
Antenna cable length.....	1-4
Antenna height .....	1-4
AREA.....	4-27
ASSISTANT DISP .....	4-38
ASSOCIATION .....	3-18
AUTO ACQ AREA .....	3-22
Auto tuning .....	1-1

### B

BCR/BCT.....	4-18
Bearing mode .....	3-12
Brilliance .....	2-5

### C

C UP .....	2-24
CFAR.....	2-11
CHART .....	4-32
CHART DISP SET.....	4-32
Coast line.....	4-25
CPA/TCPA .....	3-16

### D

DIFF.....	2-12
Display color.....	2-21
Display mode.....	2-23

### E

EBL.....	2-15
EBL OFFSET.....	2-16

Echo alarm.....	3-13
ENH .....	3-6
ERBL.....	2-20
EVENT MARK.....	4-26
External save .....	1-10

### F

Fault diagnostics.....	7-1
FILTER.....	3-39
Function key .....	2-27

### G

GAIN .....	2-7
GPS BUOY .....	4-30
GUARD ZONE.....	3-23

### H

H UP .....	2-23
Heading line.....	2-21
HISTORY LIST .....	4-8
HL OFFSET .....	1-2

### I

I / O .....	4-43
INPUT RNG .....	3-21
Inside save.....	1-6
INTER SWITCH.....	4-36
IR .....	3-7

### L

Language.....	4-41
LIST .....	4-8

**M**

Manual tuning .....	1-1
MBS .....	1-4
Menu configuration .....	4-53
MONITORED ROUTE .....	4-28

**N**

N UP .....	2-24
NAV LINE.....	4-26

**O**

Off-centering .....	2-22
Own ship profile .....	1-5

**P**

Panel illumination.....	2-5
PAST POSN.....	3-17
PAST TRK.....	4-12
PATH PREDICTOR.....	4-18
PI .....	2-17
POSITION OFFSET .....	4-29
PROCESS .....	3-4
Pulse length .....	2-13

**R**

RAIN .....	2-10
Range .....	2-6
RANGE UNIT.....	4-2
Reference point .....	1-5
Reference target.....	3-26

Relative motion .....	2-25
ROUTE (Alternate planned route).....	4-26
RR .....	3-11

**S**

SCALE .....	4-23
SEA .....	2-8
SECTOR MUTE .....	4-47
STAB .....	3-2

**T**

TEST TGT .....	3-28
TGT ID .....	3-16
TM reset.....	2-26
Trail .....	3-9
Trial manoeuvre .....	3-41
True motion .....	2-25
TT .....	3-24
TT symbol .....	3-27
TX DELAY .....	1-3

**V**

VECTOR .....	3-15
VIDEO .....	3-8
VRM .....	2-14

**Z**

ZOOM .....	4-2
------------	-----



## Koden Electronics Co., Ltd.

**Tamagawa Office:**

2-13-24 Tamagawa, Ota-ku, Tokyo, 146-0095 Japan

Tel: +81-3-3756-6501 Fax: +81-3-3756-6509

**Uenohara Office:**

5278 Uenohara, Uenohara-shi, Yamanashi, 409-0112 Japan

Tel: +81-554-20-5860 Fax: +81-554-20-5875

**[www.koden-electronics.co.jp](http://www.koden-electronics.co.jp)**